



## Coaxial Fixed Attenuator

## RFH67XX185D10

DC-67 GHz, 3-40 dB, 10 Watts, 1.85mm, Unidirectional

Rev 3

### Electrical

<b>Impedance</b>	50 ohm			
<b>Frequency Range</b>	DC-67 GHz			
<b>VSWR</b>	1.45 max			
<b>Input Avg Power</b>	10W@ 25°C ambient, derating linearly to 1W at 100°C			
<b>Peak Power</b>	50W (5 micro-sec pulse width, 6% duty cycle)			
<b>Direction</b>	Unidirectional, 1.85mm male input, 1.85mm female output (other configurations available)			

<b>Attenuation(dB)</b>	3-10	20	30	40
<b>Accuracy(dB)</b>	-1.5/+1.8	-1.2/+1.5	-1.2/+1.5	-1.2/+1.5

### Mechanical

<b>Connector Body</b>	Passivated stainless steel
<b>Heat Sink</b>	Black anodized aluminum
<b>Center Contact</b>	1.27um Gold plated BeCu
<b>Net Weight</b>	Approx 55 g

### Environmental

<b>Operating Temperature</b>	-55°C to 100°C
<b>Storage Temperature</b>	-55°C to 125°C
<b>RoHS</b>	Compliant
<b>Temperature Coefficient</b>	<0.0004 dB/dB/°C

### Dimensions(mm)

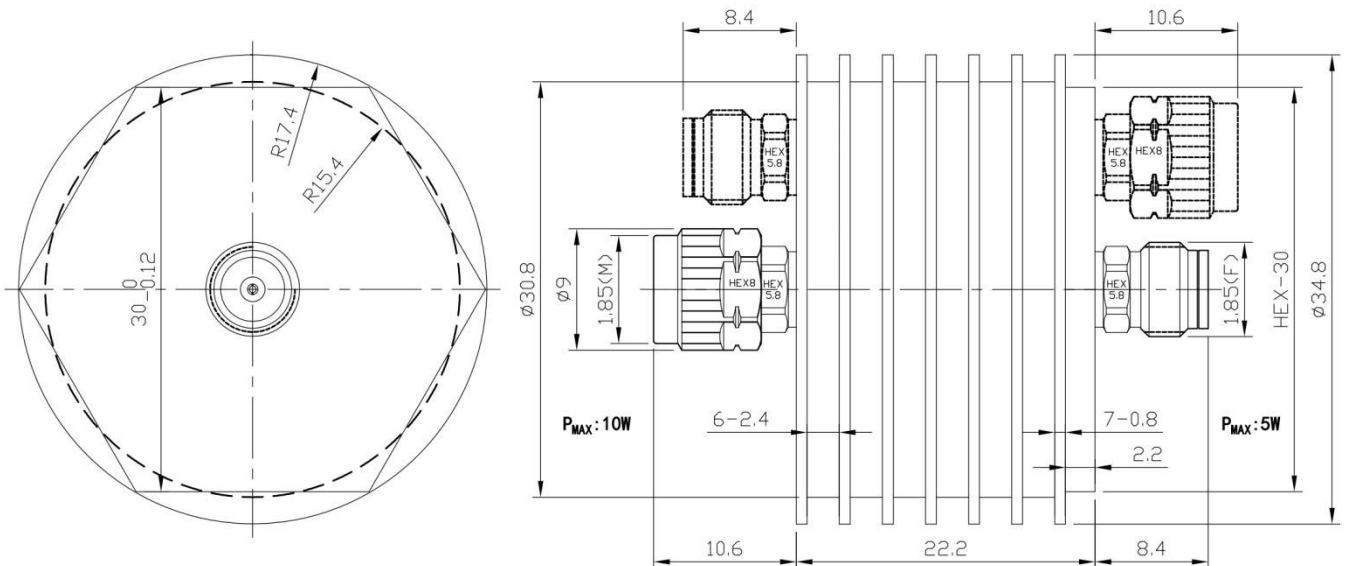

### Notes

1. Always pay attention to the direction of attenuators.
2. To maintain best performance, recommended to use fan to keep the case temperature under 85°C.
3. Customized dB values, outlines and optimal accuracy/VSWR available.

### Model Description

#### RFH67XX185D10

1. XX for dB value: 06=6dB, 30=30dB
2. Code for connector configuration:  
 A=female for two ends; B=male for two ends  
 C=female for input and male for output;  
 D=male for input and female for output.

Typical Test Data(Contact us at [sales@rfone.cn](mailto:sales@rfone.cn) for test plots of more models)

### 10dB

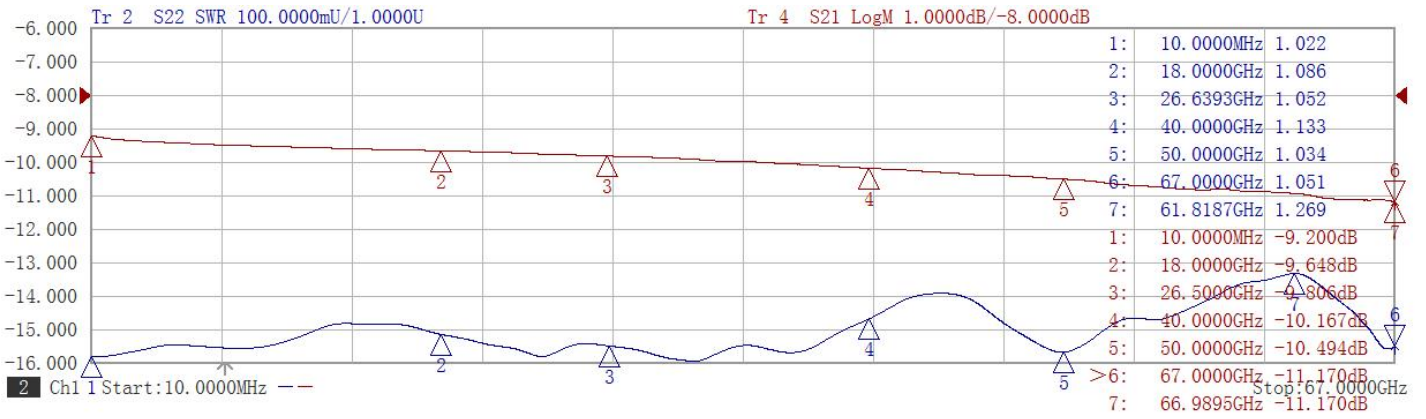

### 20dB

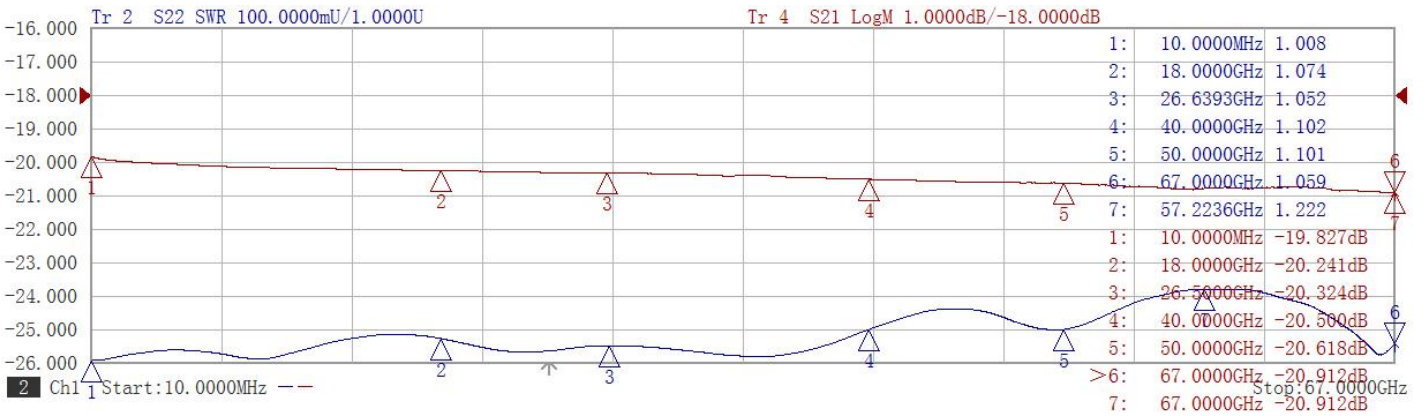

### 30dB

