

Scienlab Machine Emulator

High Power Series

SL1044A



Table of Contents

System Description	3
System Options	7
Power Option Class.....	7
SL1044A-101 Output Power – 75 kW	7
SL1044A-102 Output Power – 150 kW	7
SL1044A-103 Output Power – 300 kW	7
Extension of Sensor Emulation	7
SL1044A-080 Extension of Sensor Emulation to XMR Sensor and Failure Emulation	8
DC Output.....	9
SL1044A-040 Optional DC Output 600 A	9
Coupling Chokes	9
SL1044A-050 Standard Coupling Chokes 150 μ H	9
SL1044A-052 Coupling Chokes 500 μ H	12
Emulation of Line-Effects	14
SL1044A-070 Emulation of Line-Effects	14
Cabinet Base Option Class	14
SL1044A-701 Base stand	14
SL1044A-702 Rollers	14
Interface Options Beyond Ethernet	14
SL1044A-030 Additional EtherCAT Interface.....	14
SL1044A-031 Additional FPGA Interface.....	14
SL1044A-021 NET-Assembly License/DLL SLEP	14
Machine Modeling	15
SL1044A-060 PMSM Model Includes Definition of Look-up Tables	15
SL1044A-061 ASM Model Includes Definition of Look-up Tables	15
Service Options	16
HS0003A-100 Project Management	16
HS0002A-108 Preliminary Acceptance.....	16
R9001A-201 Installation Service	17
R9001A-202 Commissioning - Test Solution	17
HS0002A-100 Productivity Assistance.....	18

System Description

Inverters are essential components for numerous applications since they convert voltage bi-directionally. Traction inverters convert DC voltage from a battery to AC voltage for an electric machine (such as a motor). This functionality makes inverters an important component in electromobility, as well as numerous other industrial applications.

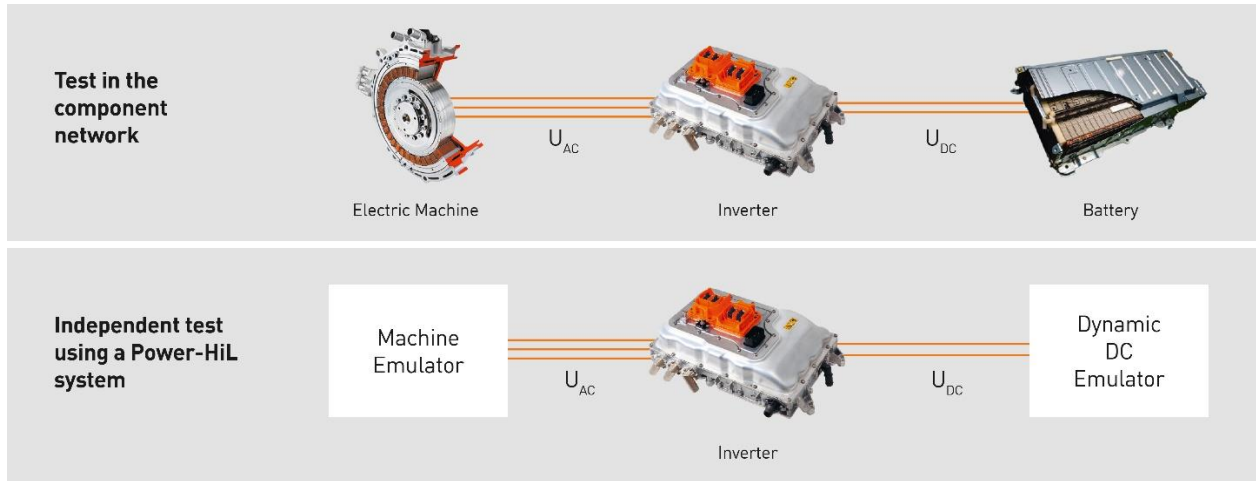

Figure 1: Emulation of components for the independent test

To allow flexible and reproducible tests, the electric machine can be replaced by a Scienlab Machine Emulator (ME) from Keysight. Depending on the configuration, the Machine Emulator can emulate one or more of the following machine types:

- Permanent Magnet Synchronous Machine (PMSM)
- Asynchronous Machine (ASM)
- External connection for open (user-defined) machine model

The Machine Emulator will be controlled by corresponding model parameters to emulate different kinds of machines to the inverter. The battery is not a real battery either; it is emulated by a Dynamic DC Emulator on the test bench. Furthermore, there are several opportunities to control the inverter test bench:

- PC-Software Emulator Control for manual testing
- HiL system for automated, model based, real-time testing (dSPACE, Vector, ...)
- Ethernet or EtherCAT interface for open control solutions

The Machine Emulator consists of:

- Control cabinet with Active Front End (AFE)
- Controller and power amplifiers
- Ethernet-Interface (including interface description in English)

System Cabinet

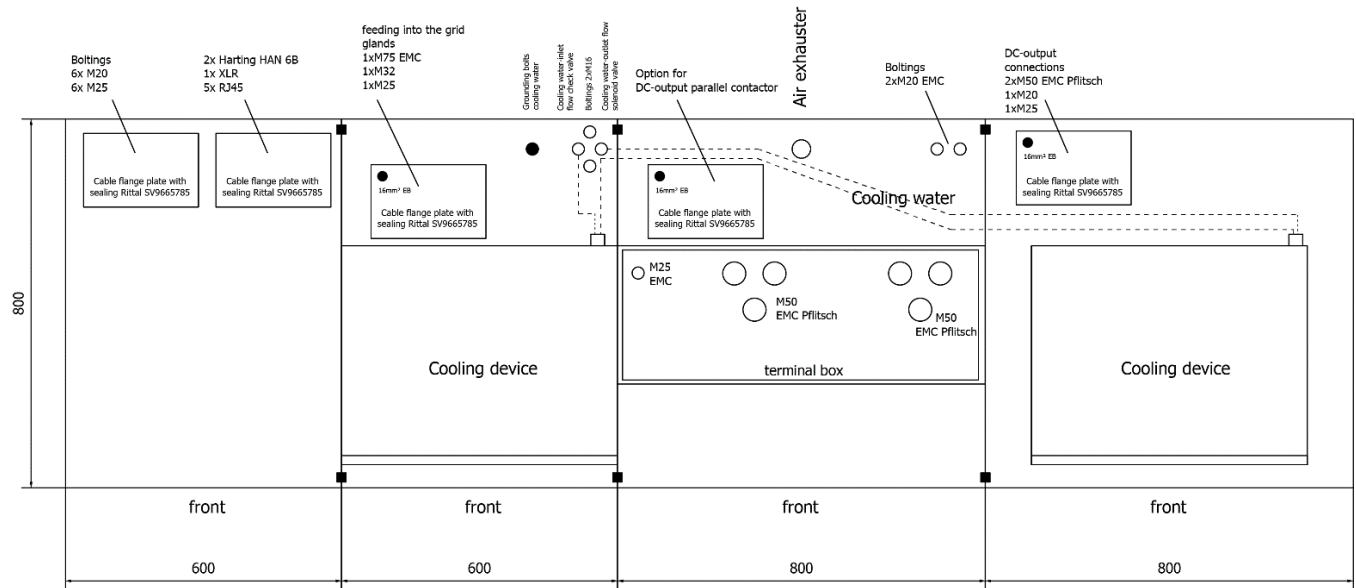

Figure 2: Top view of Machine Emulator cabinet (75 kW to 150 kW). Two cabinets required for 300 kW.

Power options	75 kW	150 kW	300 kW
Dimensions H x W x D (excl. Coupling Chokes)	2450 x 2800 x 880 mm	2450 x 2800 x 880 mm	2 x 2450 x 2800 x 880 mm
Weight approx.	1650 kg	1650 kg	3300 kg

- Protection class IP 54
- Environmental temperature: +10 to +40 °C
- Humidity: 30 to 75 % relative humidity
- Sound level according to DIN EN 3744 <70 dB(A), measured at 1 m distance on front
- 2x 230 VAC service outlets per system cabinet, accessible from the outside, door installation
- Right side door hinge
- System cabinet on rollers or base stands

AFE (Active Front End)

- Energy recovery
- Power factor compensation ($\cos \varphi > 0.98$)
- Bi-directional power flow
- HF EMC filter, 2 kHz filter
- Verification of conformity with the limits of power-related disturbances as specified by EN61000-6-4:2007
- Galvanic isolation
- Resonant converter

Mains power supply

- Mains supply
- Functional earth (FE)
- Cable connector on the roof by EMC screw connection

Power options	75 kW	150 kW	300 kW
Connection	3, PE 400 V, 50 or 60 Hz	3, PE 400 V, 50 or 60 Hz	2x 3, PE 400 V, 50 or 60 Hz
Pre-fuse	200 A gG	315 A gG	2x 315 A gG

Machine emulation

Real-time computer controls the electrical output variables according to the corresponding machine model

- Reference input: torque or speed
- Basic voltage accuracy: 0.5 % full scale, phase angle accuracy: typical 2°; maximum 5° @ 2.5 kHz
- Basic current accuracy: 1 % full scale
- Additional current measurement for transducers: 0.5 % full scale

Short-circuit management

The current by an inverter short-circuit can be specified by parameter

- Minimum machine inductance: please see Coupling Chokes on page 10
- Terminal voltage phase shift possible during short circuit activation/deactivation
- Settling time until stationary short circuit current typically requires up to 30 ms but depends on the operating point
- The short circuit current is not be actively set for low voltages (typically lower than 10 V). In general, the short circuit current is low in that case due to the resistance of the coupling inductance.

Power electronics cooling

- Water or water heat exchanger with internal water circuit
- Limiting the water flow in the cabinet
- Monitoring water temperature and internal controller
- Water stop valve

Internal cabinet cooling

- Water or air heat exchanger
- Monitoring the interior temperature and the heat exchanger temperature
- No air flow to the laboratory environment
- Roof assembly

Cooling water

Power options	75 kW	150 kW	300 kW
Heat dissipation	Maximum 10 kW	Maximum 20 kW	Maximum 40 kW
Throughput	0.16l/s or. 0.52 m ³ /h @ JZ = 15 K, JR = 20 K, DJ = 5 K	0.32l/s or. 1.15 m ³ /h @ JZ = 15 K, JR = 20 K, DJ = 5 K	0.64l/s or. 2.30 m ³ /h @ JZ = 15 K, JR = 20 K, DJ = 5 K
Maximum supply flow temperature for mentioned heat discharge above	+15 °C	+15 °C	+15 °C

- Temperature of coolant-in line: ¾", +6 °C to +20 °C
- Temperature of coolant-out line: ¾", Maximum +30 °C
- Maximum input pressure: 6 bar, free of pressure surges, differential pressure: 1.5 to 3 bar
- Water-stop valve

Interface to the superordinate test bench guard (through terminal blocks)

- Release of main power contactors
- Release of output contactors
- Status signal output contactors open / closed
- Status signal limit value violated
- Status signal collective-alarm error
- Status signal emergency stop

Safety

- Parametrizable limit values (current, voltage, power) for protection of the device under test
- Integration in the emergency stop loop of the laboratory
- Master switch off (integrated in cabinet door)
- Emergency stop button (integrated in cabinet door)
- Key switch for release of output contactors
- Door handles: convenient handles with safety lock
- Signal lamp with 3 lights, installed on a magnetic base on the cabinet roof
 - Red: error; yellow: operation, green: ready for operation

Intrinsic safety

- Built-in safeguards against overheating, over-load, short circuit and no-load operation
- Monitoring of all internal voltages, currents and temperatures
- AC output contactors, capable of disconnecting at full load current
- Main-side contactors ensure voltage-free operation
- Discharging of all internal high-voltage sources during emergency stop

Documentation

- Operating instructions in English
- Getting Started Guide in English
- CE certificate of conformity
- Final inspection and calibration protocol

Technical execution as per the common basic safety and health demands of EU directives. Special customer standards have not been considered.

System Options

Power Option Class

SL1044A-101 Output Power – 75 kW

SL1044A-102 Output Power – 150 kW

SL1044A-103 Output Power – 300 kW

Performance data

Power options	75 kW	150 kW	300 kW
Current options	600 A _{rms}		1200 A _{rms}
Voltage options	560 V _{rms}		
Fundamental electric frequency	0 to 2.5 kHz		

Extension of Sensor Emulation

The machine emulator can emulate speed/position sensors and temperature sensors by default:

Emulation of speed/position sensors

- Resolver
- Incremental encoder
- Hall sensor
- Max. output frequency up to 100 kHz

Emulation of temperature sensors

- Emulation of two temperature sensors via analog signals
- 2x output voltage 0 V to 5 V, output current up to a maximum of 10 mA

SL1044A-080 Extension of Sensor Emulation to XMR Sensor and Failure Emulation

This option enables the emulation of XMR sensors and sensor defects. Emulated XMR sensors are the Giant Magneto Resistance (GMR) and the Anisotropic Magneto Resistance (AMR) sensors.

XMR sensors:

Inputs

- V_{ref} Analog Input (V_{cc} / Resolver Exciter): -10 to 10 V

Outputs

8x analogue outputs:

- GMR, AMR, Vogt, Resolver: Sin+, Sin-, Cos+, Cos-
- AMR has twice the signal frequency compared to the GMR
- GMR has the mech. frequency of the electric motor
- Output voltage (amplitude): $-V_{ref}$ to V_{ref} (per-phase from V_{ref})
- Output voltage (offset): 0 to V_{ref} (per-generation of V_{ref})
- Frequency AMR: DC to 2.5 kHz (30000 rpm)
- Frequency GMR: DC to 500 Hz (30000 rpm)
- Sensor position: -180° to 180°
- Phase shift between the outputs (Sin / Cos): -180° to 180°
- The outputs are short circuit proof
- Maximum output current: 40 mA
- Internal resistance in the control range: 11Ω

Emulation of sensor defects

- Emulation of defects in the position and speed sensors (phase shift, gain, open terminals)
[open terminals for open drain sensor emulation not available]
- Emulation of defects in temperature sensors (short circuit, open terminals)

DC Output

SL1044A-040 Optional DC Output 600 A

Operation of the 1044A Scienlab Machine Emulator as a fully functional SL1042A Scienlab Dynamic DC Emulator.

- Software switching between Machine and Dynamic DC Emulator via customer interface

Power ME	75 kW	150 kW	300 kW
Power DCE	90 kW	180 kW	360 kW
Output current	600 A		1200 A
Voltage options	50 to 850 V		

Coupling Chokes

Coupling Chokes are necessary for the emulation of low values of machine inductance (typically values close to the smaller machine inductance work best).

SL1044A-050 Standard Coupling Chokes 150 μ H

- Base dimensions (H x W x D): 2005 mm x 800 mm x 880 mm
- Transport dimensions (H x W x D): 2005 mm x 800 mm x 880 mm
- Weight: approximately 400 kg

Output to test item (DUT) →

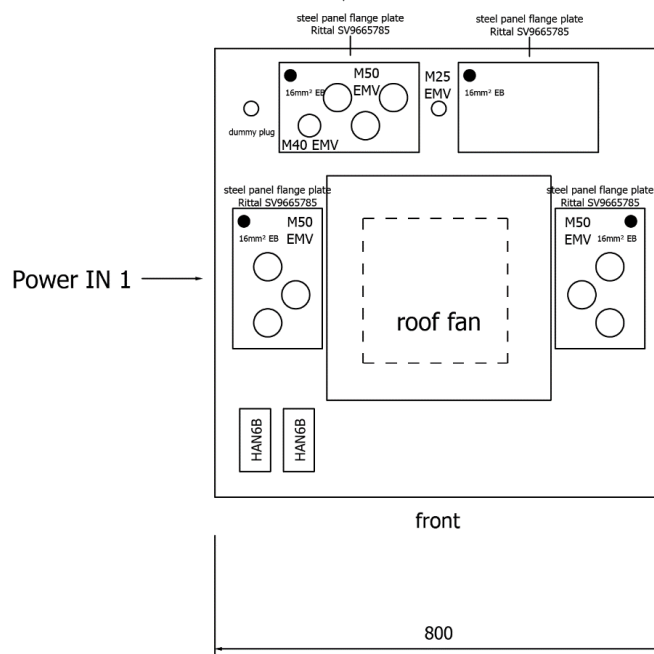

Figure 3: Example of coupling choke system (top view)

Cabinet of coupling chokes with 150 μH , per ME and phase.

For one ME:

- Connection point for two power stages
- 6 one-phase chokes 300 μH / 300 A
- Effective inductance per phase
 - 150 kW system: 150 μH
 - 300 kW system: 75 μH
- 2 Power contactors, switchable via Interface
- N coupling choke cabinets of this kind can be connected in series, to multiply the physically connected inductance
- Cabinet cooling via roof ventilator
- 1 cabinet / 2 power stage

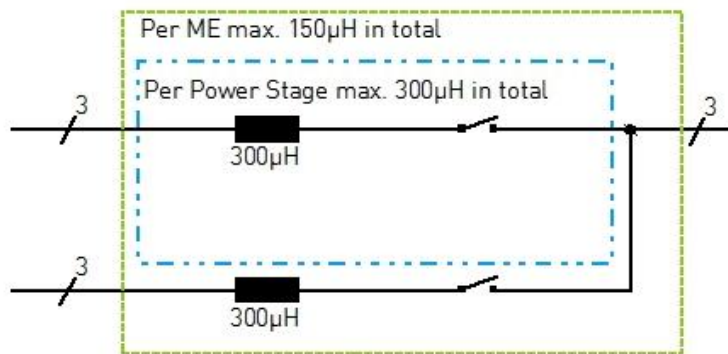

Figure 4: Exemplary block diagram

SL1044A-051 Coupling Chokes 250 μ H

- Base dimensions (H x W x D): 2800 mm x 800 mm x 880 mm
- Transport dimensions (H x W x D): 2600 mm x 800 mm x 880 mm
- Weight: approx. 500 kg

Output to test item (DUT) ←

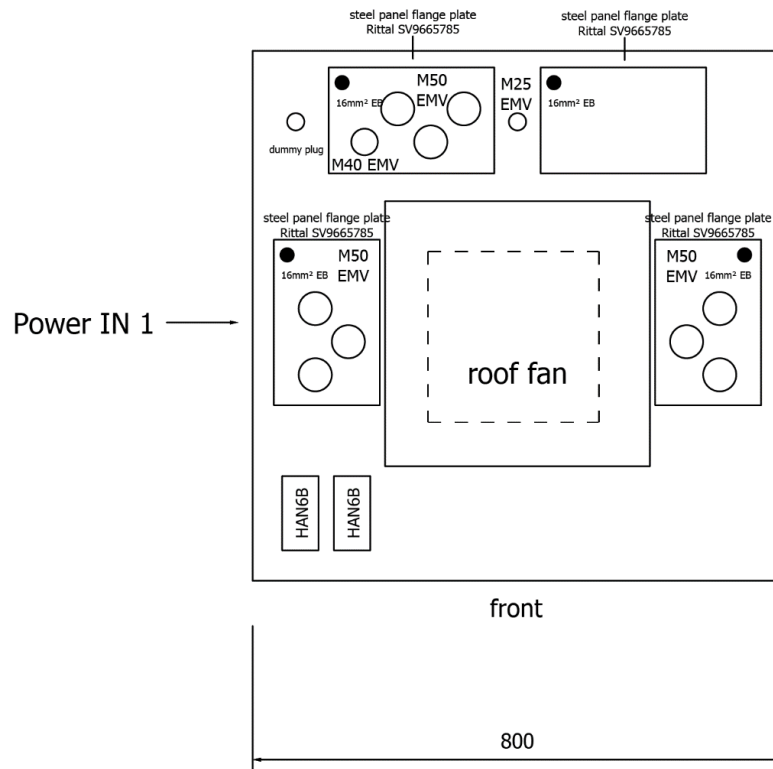

Figure 5: Example of coupling choke system (top view)

Cabinet of coupling chokes with maximum 250 μ H, per ME and phase.

For one ME:

- 6 one-phase chokes 200 μ H / 300A
- 6 one-phase chokes 300 μ H / 300A
- Maximum effective inductance per phase
 - 150 kW system: 250 μ H
 - 300 kW system: 125 μ H
- 4 Power contactors, switchable via Interface
- N coupling choke cabinets of this kind can be connected in series to multiply the physically connected inductance
- Cabinet cooling: water
- 1 cabinet / 2 power stage

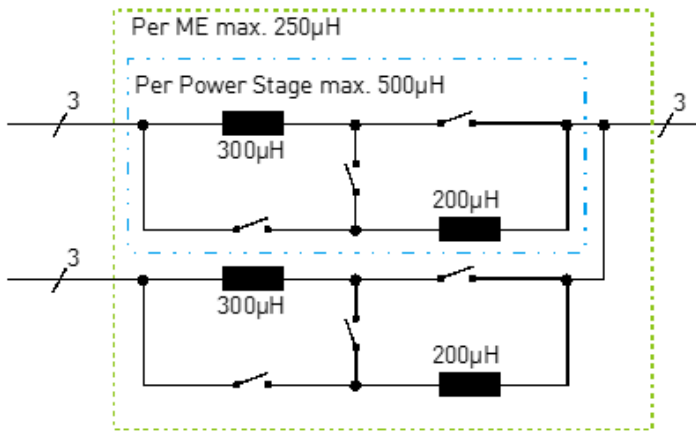

Figure 6: Exemplary block diagram

The table shows the combination of the inductance per ME

150 kW system	60 µH	100 µH	150 µH	250 µH
300 kW system	30 µH	50 µH	75 µH	125 µH

SL1044A-052 Coupling Chokes 500 µH

- One cabinet coupling Chokes cabinet has a maximum inductance of 1000 µH. For this variant, one ME requires two cabinets. One cabinet has the following Date
- Base dimensions (H x W x D): 2800 mm x 1600 mm x 880 mm
- Transport dimensions (H x W x D): 2600 mm x 800 mm x 880 mm
- Weight: approx. 1000 kg

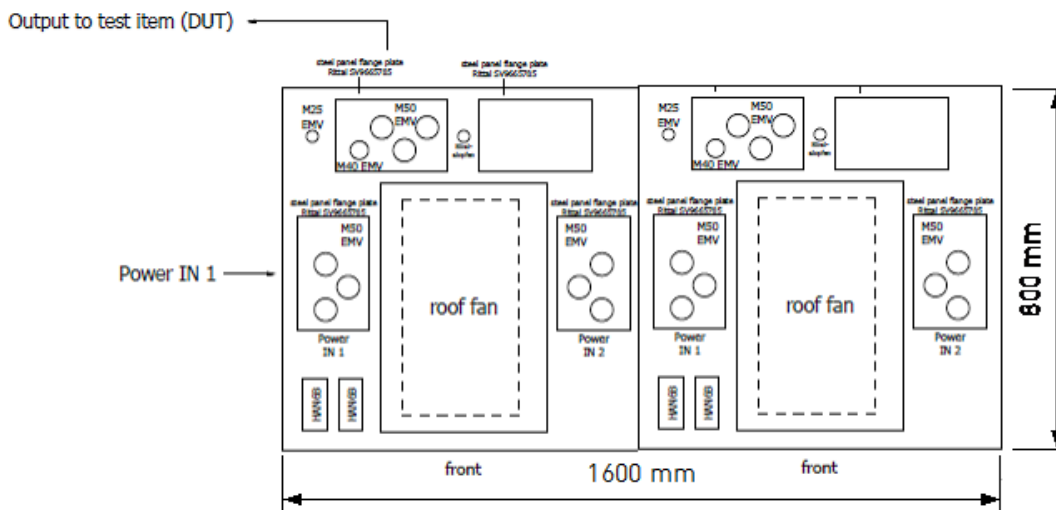

Figure 7: Example of coupling choke system (top view)

Cabinet of coupling chokes with maximum 500 μH , per ME and phase.

For one ME:

- 12 one-phase chokes 200 μH / 300 A
- 12 one-phase chokes 300 μH / 300 A
- Maximum effective inductance per phase
 - 150 kW system: 500 μH
 - 300 kW system: 250 μH
- 12 Power contactors, switchable via Interface
- N coupling choke cabinets of this kind can be connected in series, in order to multiply the physically connected inductance
- Cabinet cooling: water
- 2 cabinet / 2 power stage

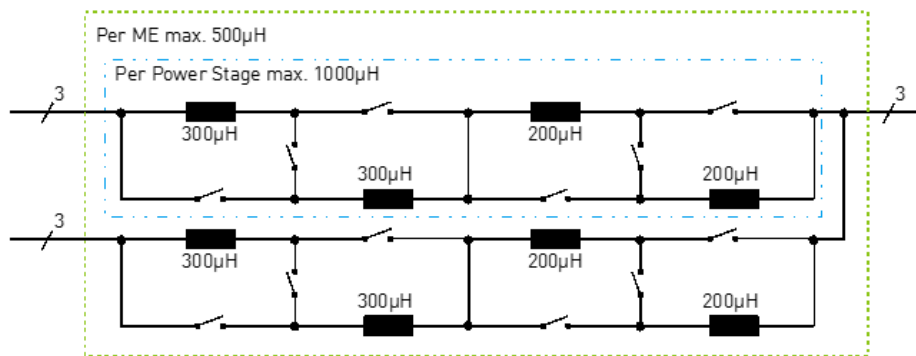

Figure 8: Draft of switching matrix

The table show the combination of the inductance per ME

150 kW system	50 μH	75 μH	100 μH	125 μH	150 μH	175 μH	200 μH	250 μH	275 μH	300 μH	350 μH	400 μH	500 μH
300 kW system	25 μH	38 μH	50 μH	63 μH	75 μH	88 μH	100 μH	125 μH	138 μH	150 μH	175 μH	200 μH	250 μH

Emulation of Line-Effects

SL1044A-070 Emulation of Line-Effects

Short circuit and interruption (open circuit) of single lines on the machine terminal during operation up to 600 A / 150 kW.

- Three-phase short circuit
- Two-phase short circuit via all three phases
- One, two and three-phase failure
- Error case selectable via interface
- Error cases realized by power contactors

Cabinet Base Option Class

SL1044A-701 Base stand

Control cabinet is placed on top of a 15 cm high base stand.

SL1044A-702 Rollers

Control cabinet stands on top of 25 cm high rollers and can be moved.

Interface Options Beyond Ethernet

SL1044A-030 Additional EtherCAT Interface

Control cabinet is equipped with an extra EtherCAT interface.

- EtherCAT – interface description in English

Note: This option cannot be combined with the FPGA interface.

Note: When using dSpace HiL this option is not necessary for the communication between the emulator and the HiL.

SL1044A-031 Additional FPGA Interface

Control cabinet is equipped with an extra interface for external dSpace FPGA.

Note: This option is required if external dSpace FPGA in SL1020A is selected.

Note: This option cannot be combined with the EtherCAT interface.

SL1044A-021 NET-Assembly License/DLL SLEP

DLL driver for direct connection of DC Emulator or Machine Emulator in external MS Windows Applications via Ethernet (e.g. LabView).

Machine Modeling

SL1044A-060 PMSM Model Includes Definition of Look-up Tables

Anisotropic machine model of a Permanent Magnet Synchronous Machine (PMSM) for generator and motor operation.

Basic system parameters:

- d-Axis inductance L_d [25 μ H to 1000 μ H]
- q-Axis Inductance L_q [25 μ H to 1000 μ H]
- Stator resistance R_s [1 m Ω to 10 Ω]
- Excitation flow Ψ_{PM}
- Mechanical moment of inertia J_{mech}
- Number of pole pairs p [1 to 20]

The actual range of inductance values may depend on the operating point. The available range of machine operation depends on the machine characteristics and, if required, may be evaluated by Keysight.

Definition of look-up tables

Parameters dependencies can be specified in up to two dimensions $x = f(y,z)$.

Examples of application:

- Inductance saturation
- Temperature dependency of Ψ_{PM} (PMSM)
- Characteristic lines of (temperature) sensors
- Mechanical friction losses

SL1044A-061 ASM Model Includes Definition of Look-up Tables

Asynchronous Machine (ASM) with squirrel-cage rotor for generator and motor operation

Basic system settings:

- Stator resistance R_s
- Rotor resistance R_r
- Stator leakage inductance L_{ls}
- Rotor leakage inductance L_{lr}
- Magnetic coupling inductance L_m
- Coupling factor stator / rotor
- Mechanical moment of inertia J_{mech}
- Number of pole pairs p

The actual range of inductance may depend on the operating point. The available range of operation of the machine depends on the machine characteristics and, if required, may be evaluated by Keysight.

Definition of look-up tables

Parameters dependencies can be specified in up to two dimensions $x = f(y,z)$.

Examples of application:

- Inductance saturation
- Characteristic lines of (temperature) sensors
- Mechanical friction losses

Service Options

Service features depend on the customer facilities and expertise and overall scope of the project. For that reason, it is not possible to give exact service efforts without knowing the requirements and goals of the customer. Keysight offers the following services to ensure a successful project execution and to reduce the ramp-up time for our customers.

HS0003A-100 Project Management

Project Management is recommended for each test bench project. By ordering the Project Management service, an experienced project manager dedicated to your project acts as a direct communication interface from Keysight to the customers Project Management Team.

The project manager takes over the responsibility:

- To observe internal project progress and insure that project schedule/ project milestones are kept.
- That any unscheduled occasions with relevance for the project are immediately communicated and discussed with the customer.
- To provide complete and accurate project documentation to the customer.

HS0002A-108 Preliminary Acceptance

The Preliminary Acceptance implements the customer's Device Under Test (DUT) into the test environment before delivery. It is important to get the customer's DUT for the preliminary acceptance. Without the customer's DUT, a preliminary acceptance is not possible. The preliminary acceptance is required for new customers.

- This position also includes training for the customer.
- Recommended: Bochum, Germany

Note: The preliminary acceptance is valid for one DUT. It is necessary and important to send the document '*Checklist Inverter Test Bench*,' including all mentioned files in the document, to Keysight Bochum eight weeks before the preliminary acceptance. Please contact your sales representative if you did not get the mentioned document.

R9001A-201 Installation Service

The scope of the offered Installation Service depends on the individual customer facility. Please share all relevant information and requirements regarding test bench components that require installation. Such requirements include connection to the local grid and local water supply. This allows your local field engineer to calculate the scope of service personnel and material costs for installation.

Note: Installation can also be executed by the customer.

Required output cables for 600 A Systems:

- Emulator ↔ Chokes: approx. 6 x 4 meter 4G50 mm²
(Recommended: Ölflex Classic 100 CY)
- Chokes ↔ DUT: approx. 3 x 6 meter 300 mm²
(Recommended: Ölflex FD90CY)
- Chokes ↔ DUT: approx. 3 x 6 meter 150 mm²
(Recommended: Ölflex FD90CY PE) (if required)

Note: The actual length of the cables depends on the lab layout. The sum (Emulator ↔ Chokes ↔ DUT) must not exceed 10 meters.

Note: For 1200 A Systems, double the amount of cables is required. The cables need to be connected in parallel at the DUT side.

R9001A-202 Commissioning - Test Solution

The Commissioning Service guides the customer during first usage of the test bench after installation. Commissioning is recommended for each test bench. It includes:

- Local presence of experienced test bench engineer during first usage of the test bench.
- Consulting with customer personnel with regards to intended usage of the test bench (e.g. initial test with customer specimen)
- Review of executed hardware installation of Keysight products.
- Review and consulting per software settings of operation software if ordered
- Travel expenses

Note: Commissioning is offered on a daily base. Keysight recommends at least 12 days of Commissioning Service for each test bench.

HS0002A-100 Productivity Assistance

The Productivity Assistance is offered to support, consult, and train the customer's operation personnel to reduce the ramp-up time for initial usage of a new test bench and for any unexpected system behavior during the test bench life cycle. Productivity Assistance is executed either remotely (phone/ Internet) or on site (on request). It includes:

- Direct access to an experienced system specialist via Phone/Internet
- Support for failure analysis and trouble shoot
- Software and programming support & consulting

Note: Keysight recommends at least two days of Productivity Assistance for each test bench project.

Learn more at: www.keysight.com

For more information on Keysight Technologies' products, applications or services, please contact your local Keysight office. The complete list is available at: www.keysight.com/find/contactus

