

# **RIGOL**

**快速指南**

## **M300 系列数据采集/开关系统**

**2021 年 5 月**  
**RIGOL TECHNOLOGIES CO., LTD.**



# 保证和声明

## 版权

© 2021 普源精电科技股份有限公司

## 商标信息

**RIGOL**®是普源精电科技股份有限公司的英文名称和商标。

## 文档编号

QGC07010-1110

## 声明

- 公司产品受中国及其它国家和地区的专利(包括已取得的和正在申请的专利)保护。
- 本公司保留改变规格及价格的权利。
- 本手册提供的信息取代以往出版的所有资料。
- 本手册提供的信息如有变更,恕不另行通知。
- 对于本手册可能包含的错误,或因手册所提供的信息及演绎的功能以及因使用本手册而导致的任何偶然或继发的损失, **RIGOL** 概不负责。
- 未经 **RIGOL** 事先书面许可,不得影印、复制或改编本手册的任何部分。

## 产品认证

**RIGOL** 认证本产品符合中国国家产品标准和行业产品标准及 ISO9001:2015 标准和 ISO14001:2015 标准,并进一步认证本产品符合其它国际标准组织成员的相关标准。

## 联系我们

如您在使用此产品或本手册的过程中有任何问题或需求,可与 **RIGOL** 联系:

电子邮箱: [service@rigol.com](mailto:service@rigol.com)

网址: [www.rigol.com](http://www.rigol.com)

# 安全要求

## 一般安全概要

了解下列安全性预防措施，以避免受伤，并防止损坏本产品或与本产品连接的任何产品。为避免可能的危险，请务必按照规定使用本产品。

### 使用正确的电源线。

只允许使用所在国家认可的本产品专用电源线。

### 将产品接地。

本产品通过电源电缆的保护接地线接地。为避免电击，在连接本产品的任何输入或输出端子之前，请确保本产品电源电缆的接地端子与保护接地端可靠连接。

### 正确连接探头。

如果使用探头，探头地线必须连接到接地端上。请勿将探头地线连接至高电压，否则，可能会在示波器和探头的连接器、控制设备或其它表面上产生危险电压，进而对操作人员造成伤害。

### 查看所有终端额定值。

为避免起火和过大电流的冲击，请查看产品上所有的额定值和标记说明，请在连接产品前查阅产品手册以了解额定值的详细信息。

### 使用合适的过压保护。

确保没有过电压（如由雷电造成的电压）到达该产品。否则操作人员可能有遭受电击的危险。

### 请勿开盖操作。

请勿在仪器机箱打开时运行本产品。

### 请勿将异物插入风扇的排风口。

请勿将异物插入风扇的排风口以免损坏仪器。

### 使用合适的保险丝。

只允许使用本产品指定规格的保险丝。

### 避免电路外露。

电源接通后，请勿接触外露的接头和元件。

### 怀疑产品出故障时，请勿进行操作。

如果您怀疑本产品出现故障，请联络 RIGOL 授权的维修人员进行检测。任何维护、调整或零件更换必须由 RIGOL 授权的维修人员执行。

### 保持适当的通风。

通风不良会引起仪器温度升高，进而引起仪器损坏。使用时应保持良好的通风，定期检查通风口和风扇。

**请勿在潮湿环境下操作。**

为避免仪器内部电路短路或发生电击的危险，请勿在潮湿环境下操作仪器。

**请勿在易燃易爆的环境下操作。**

为避免仪器损坏或人身伤害，请勿在易燃易爆的环境下操作仪器。

**请保持产品表面的清洁和干燥。**

为避免灰尘或空气中的水分影响仪器性能，请保持产品表面的清洁和干燥。

**防静电保护。**

静电会造成仪器损坏，应尽可能在防静电区进行测试。在连接电缆到仪器前，应将其内外导体短暂接地以释放静电。

**正确使用电池。**

如果仪器提供电池，严禁将电池暴露于高温或火中。要让儿童远离电池。不正确地更换电池可能造成爆炸（警告：锂离子电池）。必须使用 **RIGOL** 指定的电池。

**注意搬运安全。**

为避免仪器在搬运过程中滑落，造成仪器面板上的按键、旋钮或接口等部件损坏，请注意搬运安全。

## 安全术语和符号

本手册中的安全术语：



**警告**

警告性声明指出可能会造成人身伤害或危及生命安全的情况或操作。



**注意**

注意性声明指出可能导致本产品损坏或数据丢失的情况或操作。

产品上的安全术语：

**DANGER**

表示您如果不进行此操作，可能会立即对您造成危害。

**WARNING**

表示您如果不进行此操作，可能会对您造成潜在的危害。

**CAUTION**

表示您如果不进行此操作，可能会对本产品或连接到本产品的其他设备造成损坏。

产品上的安全符号：



高电压



安全警告



保护性接地端



壳体接地端



测量接地端

## 保养与清洁

### 保养

请勿将仪器放置在长时间受到日照的地方。

### 清洁

请根据使用情况经常对仪器进行清洁。方法如下：

- 1 断开电源。
- 2 用柔和的清洁剂或清水浸湿软布擦拭仪器外部，请注意不要将水或其他异物通过散热孔进入机箱内。清洁带有液晶显示屏的仪器时，请注意不要划伤 LCD 显示屏。



#### 注意

请勿使任何腐蚀性的液体沾到仪器上，以免损坏仪器。



#### 警告

重新通电之前，请确认仪器已经干透，避免因水分造成电气短路甚至人身伤害。

## 环境注意事项

以下符号表明本产品符合WEEE Directive 2002/96/EC 所制定的要求。



### 设备回收

本产品中包含的某些物质可能会对环境或人体健康有害，为避免将有害物质释放到环境中或危害人体健康，建议采用适当的方法回收本产品，以确保大部分材料可正确地重复使用或回收。有关处理或回收的信息，请与当地权威机构联系。

您可以点击如下链接 <https://www.rigol.com/services/declaration.html> 下载 RoHS&WEEE 认证文件的最新版本。

# 目录

保证和声明 .....	I
安全要求.....	II
一般安全概要 .....	II
安全术语和符号 .....	III
保养与清洁 .....	V
环境注意事项 .....	V
文档概述.....	1
快速入门.....	1
一般性检查 .....	1
外观尺寸.....	2
前面板.....	3
后面板.....	6
开机检查.....	10
用户界面.....	11
插入式模块概述.....	12
外观图 .....	12
向主机中插入模块.....	13
模块简介 .....	14
使用内置帮助系统 .....	16
菜单快速导航 .....	17
Config .....	17
Monitor .....	18
视图切换键.....	18
Control.....	19
报警通道设置键 .....	19
基本操作.....	20
测量连接.....	20
配置扫描列表 .....	24
配置拷贝.....	26
通道监视.....	27
远程控制.....	27
故障处理.....	29



## 文档概述

本手册概述 M300 系列数据采集/开关系统的前后面板、用户界面及其基本测量的操作方法，旨在指导用户快速熟悉仪器。更多详细的信息，请查阅本产品用户手册。

## 快速入门

本部分概述 M300 系列数据采集/开关系统的前后面板、用户界面以及各插入式模块的基本信息。

### 一般性检查

#### 1 检查运输包装

如运输包装已损坏，请保留被损坏的包装或防震材料，直到货物经过完全检查且仪器通过电性和机械测试。

因运输造成仪器损坏，由发货方和承运方联系赔偿事宜。**RIGOL**公司恕不进行免费维修或更换。

#### 2 检查整机

若存在机械损坏或缺失，或者仪器未通过电性和机械测试，请联系您的 **RIGOL** 经销商。

#### 3 检查随机附件

请根据装箱单检查随机附件，如有损坏或缺失，请联系您的**RIGOL**经销商。

# 外观尺寸



图 1 正视图

单位：毫米 mm

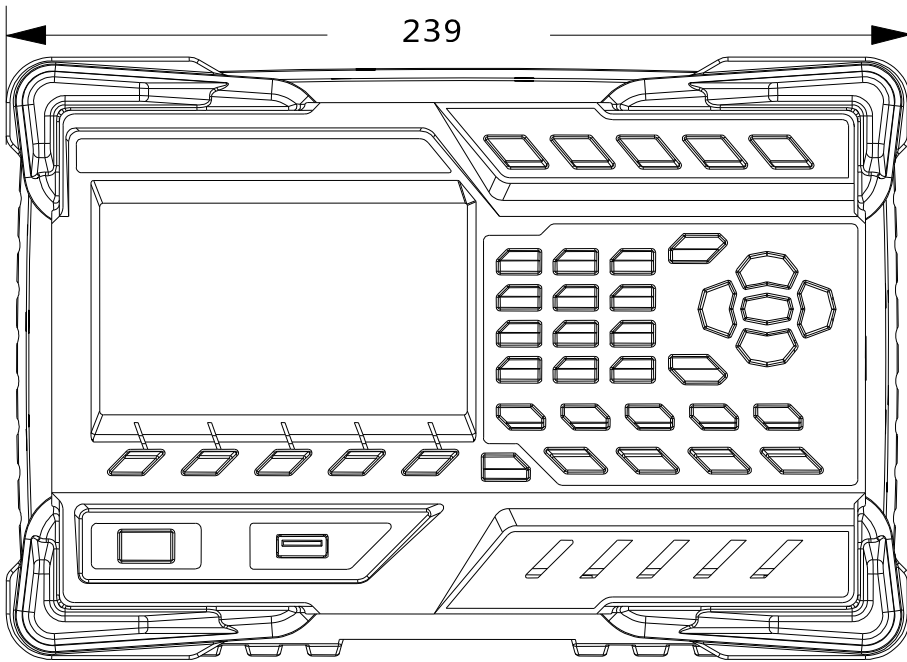

图 2 侧视图

单位：毫米 mm

## 前面板

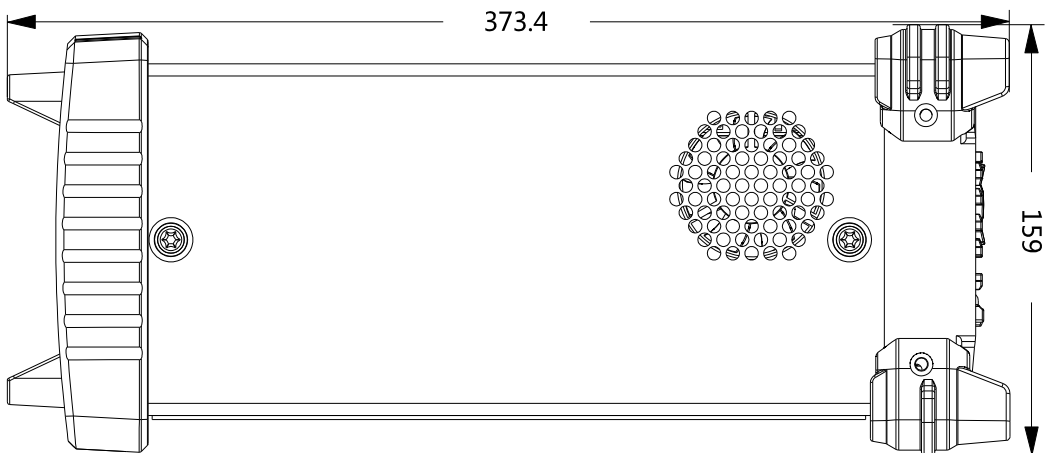

图 3 M300 前面板

### 1 液晶显示屏

4.3 英寸高清晰彩色液晶显示屏，显示菜单、配置向导、测量参数、系统状态以及提示消息等。

### 2 功能键

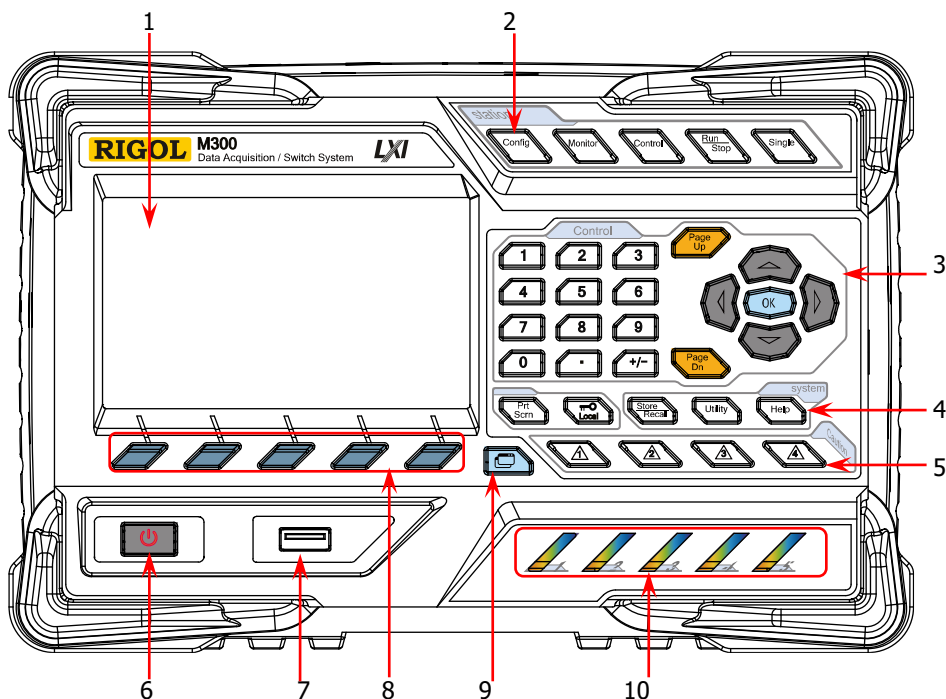

配置扫描列表及各通道的测量参数。

- 创建、编辑、读取、保存扫描列表。
- 设置扫描次数、触发模式和扫描间隔时间。
- 提供通道配置向导，可配置通道的测量参数、定标参数、报警参数和高级测量参数。



开启或关闭通道监视功能。

- 支持单通道、多通道和全通道监视功能。
- 单通道监视功能下，您可以随时变换被监视的通道。
- 多通道监视功能下，您可以监视当前扫描列表中最多7个通道。
- 全通道监视功能下，您可以监视当前扫描列表中的所有通道。



控制当前已插入的模块。

- 控制模块各通道的状态。

- 初始化各模块。
- 配置多功能模块。
- 不可控制 DMM 模块。



自动触发/停止

按下该按键，仪器开始触发或进入等待触发状态，背灯点亮。此时，长按该按键，仪器停止触发或退出等待触发状态，背灯熄灭。

**注意：**当前扫描列表为空时，该按键无效。



单通道切换

仪器处于单通道监视界面时，按下该按键可将被监视的通道切换为扫描列表中的下一通道；仪器处于其它界面时，按下该按键，仪器进入单通道监视界面。

### 3 控制键

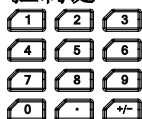

数字键盘

- 提供数字（0-9）、小数点（.）和正负号（+/-）。
- 用于输入参数值、日期和时间等。



用于打开当前界面的上一页或下一页。

**注意：**该按键区别于菜单翻页键（**上一页** 或 **下一页**）。



方向键和确认键。

### 4 系统键



若当前仪器已连接 U 盘，按下该键将屏幕当前内容以\*.bmp 格式保存到 U 盘中。**注意：**M300 仅支持 FAT32 格式 Flash 型 U 盘。



- 仪器工作在本地模式时，按下该键锁定前面板。此时，前面板除该键之外的其它按键无效。长按该键解锁前面板。



- 仪器工作在远程模式时，按下该键切换到本地模式。

存储和调用系统配置、测量配置、测量数据等文件。

- 可将文件存储到内部非易失性存储器或外部 U 盘。
- 可读取已存储的文件。



配置系统相关参数。

- 设置时间、日期、系统语言、显示亮度等参数。
- 配置远程接口（RS232、LAN、GPIB、USB）参数。
- 查询系统信息（设备型号、序列号等）。
- 执行自检并查看各模块的信息（名称、型号等）。
- 系统升级。



打开内置帮助系统。提供前面板各功能按键以及各菜单项的中英文帮助信息。

## 5 报警通道设置



M300 提供 4 个报警通道。报警产生时，后面板 Alarms/Ext Trig 接口（由 [RS-232/Alarms/Ext Trig] 接口转换而来）对应的引脚产生脉冲输出。按下对应的按键，您可以设置对应引脚的输出方式。

## 6 电源开关



按下该键可启动或关闭仪器。

## 7 USB Host



通过该接口，M300 可作为主设备，连接 U 盘以存储或调用仪器状态、测量配置、测量数据等文件。**注意：**M300 仅支持 FAT32 格式 Flash 型 U 盘。

## 8 菜单软键

与其上方的菜单一一对应。按下任一软键激活对应的菜单。

## 9 视图切换



查看扫描历史信息、通道状态表、测量曲线和通道信息。

- 扫描历史信息：可查看最近一次扫描的开始时间、扫描圈数、扫描值个数、通道号及其对应的功能、测量的最大值、最小值、平均值、标准偏差以及各通道的扫描读数。
- 通道状态表：显示各通道当前的状态。
- 测量曲线：显示指定通道的测量曲线。
- 通道信息：查看所有模块上各继电器的开关次数、当前扫描的报警信息（各报警通道上的前 100 个，包括报警产生时的读数和 时间）和错误信息（最多 20 个）。

**注意：**每个报警通道上的前 100 个报警信息被存储至报警队列中，之后的报警信息将丢失。错误队列最多可存储前 20 个错误信息，之后的错误信息也将丢失。

## 10 模块指示灯



与后面板 5 个槽位一一对应。当后面板的槽位插入模块时，对应的指示灯点亮。

## 后面板



图 4 M300 后面板

### 1 槽位

M300 提供 5 个槽位，可插入任意 5 个模块。上图中从左到右的 5 个槽位依次与前面板 5 个模块指示灯对应。某一槽位插入模块时，前面板对应的指示灯点亮。图 4 为未插入模块的效果图。欲了解各模块的相关信息，请参考“插入式模块概述”一节。

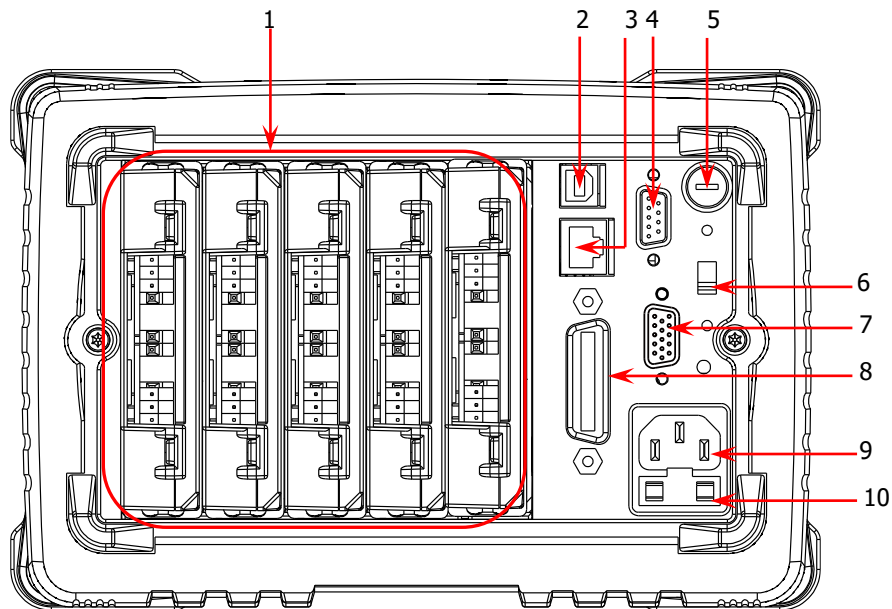

### 注意

一台主机只允许插入一个 DMM 模块。

### 2 USB Device 接口

通过该接口，M300 作为从设备，可与计算机建立通信。您可以通过计算机远程控制该仪器。

### 3 LAN 接口

M300 符合 LXI Core 2011 Device 类仪器标准。通过该接口将仪器连接至网络中，您可以通过位于同一网络中的计算机远程控制该仪器。

### 4 模拟总线接口 (Female)

M300 提供两个二线内部模拟总线用于信号路由，并提供模拟总线的外部接口（即模拟总线接口）。该接口为 9 针母型接口。

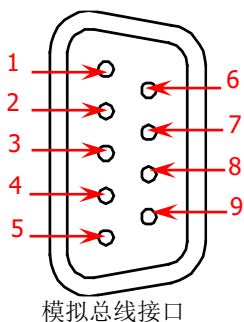

引脚	定义
1	Current Input
2	Lo
3	LoSense
4	—
5	—
6	Hi
7	HiSense
8	Float GND
9	—

## 5 DMM模块电源保险丝

由电源插口接入的交流电源被分成两路。一路为DMM模块供电，另一路为除DMM模块以外的其它电路供电。M300在此处提供DMM模块电源保险丝（规格为AC 250V T250 mA）。如需更换保险丝，请按照下面的方法进行更换：

- 1) 关闭仪器，拔除电源线。
- 2) 使用一字螺丝刀按下保险丝盖并顺时针旋转。
- 3) 在电压选择器处选择正确的电压档位。
- 4) 卸下保险丝帽和保险丝。
- 5) 更换指定规格的保险丝，将保险丝帽重新装入。



### 注意

为避免电击或火灾，请使用指定规格的保险丝。

## 6 电压选择器

M300 支持两种交流电压规格：115 V 和 230 V。请根据您所使用的交流电规格选择正确的电压档位。

## 7 RS-232/Alarms/Ext Trig 混合接口 (Male)

该接口为 15 针公头接口，其定义如下表所示。

引脚	功能	引脚	功能
1	Alarm1 Output	9	PC_RX Output
2	Alarm2 Output	10	PC_DSR Output
3	Alarm3 Output	11	GND —
4	Alarm4 Output	12	PC_DTR Input
5	CH Close Output	13	PC_CTS Output
6	Trig Input	14	PC_RTS Input
7	GND —	15	NC —
8	PC_TX Input	—	—

使用混合接口拆分线（附件）可将该接口转换为 2 个具有 9 引脚的接口。其中，一个为 9 引脚公头，用作标准 RS232 接口；另一个为 9 引脚母头，用于报警输出和外部触发信号输入等。

- **RS232:** 通过该接口，M300 可与计算机建立通信。您可以通过计算机远程控制该仪器。

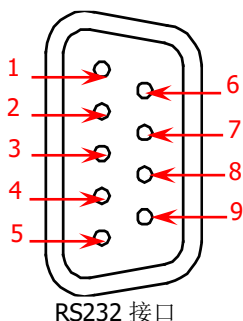

引脚	名称	定义
1	--	--
2	RXD	接收数据(Received Data)
3	TXD	发送数据(Transmitted Data)
4	DTR	数据终端准备就绪(Data Terminal Ready)
5	SGND	信号地(Signal Ground)
6	DSR	数据准备就绪(Data Set Ready)
7	RTS	请求发送(Request To Send)
8	CTS	清除发送(Clear To Send)
9	--	--

- **Alarms/Ext Trig:** 如下图所示，引脚 1 至引脚 4 用于在相应报警通道产生报警时输出 TTL 脉冲。引脚 6 用于接收外部触发信号。在连接外部数字万用表进行测量时，引脚 5 和引脚 6 共同用于控制测量。

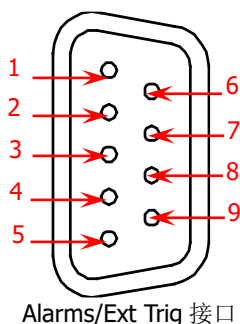

引脚	定义
1	报警通道 1 输出(Alarm 1 Output)
2	报警通道 2 输出(Alarm 2 Output)
3	报警通道 3 输出(Alarm 3 Output)
4	报警通道 4 输出(Alarm 4 Output)
5	通道关闭输出(Channel Closed Output)
6	外部触发输入/通道高级输入 (Ext Trig Input/Channel Advance Input)
7	地(GND)
8	未使用(Not Used)
9	未使用(Not Used)

#### 说明:

每次测量完成时，引脚 5 输出 TTL 负脉冲，脉宽约为  $7\mu\text{s}$ ，输出速度与实际测量速度有关，不超过 1000 次/秒。

外部触发模式下，当引脚 6 接收到脉冲宽度大于或等于  $2\mu\text{s}$  且具有指定边沿（按 **Config** 键，选择“外部”触发模式后，在 **边沿类型** 项中选择“上升沿”或“下降沿”）的外部触发信号时，仪器开始触发。若外部触发信号为连续脉冲，请确保脉冲周期大于  $100\mu\text{s}$ 。

## 8 GPIB 接口

M300 符合 IEEE-488.2 规范。通过该接口，M300 可与计算机建立通信。您可以通过计算机远程控制该仪器。

## 9 电源插口

M300 可输入两种规格的交流电源。使用附件提供的电源线将交流电通过该插口接入仪器中。



**注意**

连接交流电之前，请先选择正确的电压档位（使用**电压选择器**）。

---

**10 电源保险丝**

M300电源保险丝的规格为AC 250V T3.15 A。如需更换，请按照如下步骤操作：

- 1) 关闭仪器，拔除电源线。
- 2) 使用小一字螺丝刀插入电源插口处的凹槽，撬出保险丝座。
- 3) 更换指定规格的保险丝。
- 4) 将保险丝座重新装入卡槽中。

**注意**

为避免电击或火灾，请使用指定规格的保险丝并确保保险丝支架没有短路。

---

## 开机检查

### 1 连接电源

- 1) 根据您的供电电压调节仪器后面板的电源电压选择器。M300 支持两种类型的交流电压输入：  
供电电压处于  $115*(100\%-10\%)V$  至  $115*(100\%+10\%)V$  范围内，请选择 115；  
供电电压处于  $230*(100\%-10\%)V$  至  $230*(100\%+10\%)V$  范围内，请选择 230。
- 2) 使用附件提供的电源线将仪器连接至交流电源。

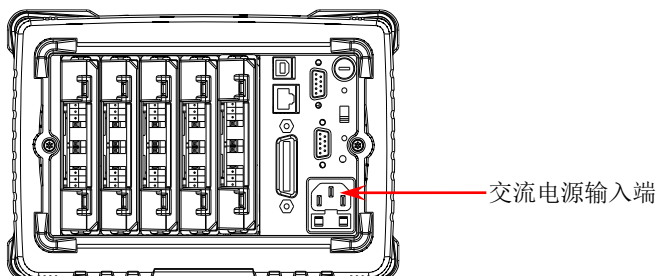

### 2 启动仪器

按下前面板电源开关。此时，仪器启动。

仪器启动后会检测模块，根据您插入模块数量的不同，此过程可能需要几秒至几十秒的时间，检测过程中 M300 不允许用户操作。

### 3 若仪器未正常启动，请按照如下步骤进行检查

- 检查电源线是否已正确连接。
- 检查前面板电源开关是否已经打开。
- 拔掉电源线，检查电压选择器是否处于正确的档位，电源输入保险丝是否已经熔断。如果已经熔断，请按要求更换保险丝。
- 做完上述检查后，重新启动仪器。
- 如果故障仍然存在，请与 **RIGOL** 联系。

## 用户界面



图 5 用户界面

### 1 状态栏

- Help 打开内置帮助时显示。
- Error 产生错误时显示。
-  锁定键盘时显示。
-  产生报警时显示。
-  系统声音关闭时显示。
-  仪器正确连接至网络时显示。
-  仪器检测到 U 盘时显示。
- Local 仪器工作在本地模式时显示。
- Rmt 仪器工作在远程模式时显示。

### 2 内容栏

显示测量配置向导、测量参数配置等内容，更多信息请参考本产品用户手册。

### 3 菜单栏

显示当前功能的菜单，与其下方的菜单软键一一对应。按下软键激活相应的菜单。

## 插入式模块概述

M300 提供 DMM 模块、20 通道多路复用器、32 通道多路复用器、64 通道单端多路复用器、多功能模块等共 10 种插入式模块。本节概述 M300 各模块的功能与特点。

### 外观图



图 6 插入式模块外观图

## 向主机中插入模块

向主机中插入模块之前，请首先关闭主机，然后按下述说明进行安装。

如图 6，模块上下各有一条外露的金色电路板边缘。将模块的两条边缘对准主机插槽内的滑槽（如下图箭头所示）后推入，听到“咔嗒”的声音表明已插入到位。此时，接口 2 已与主机连接。

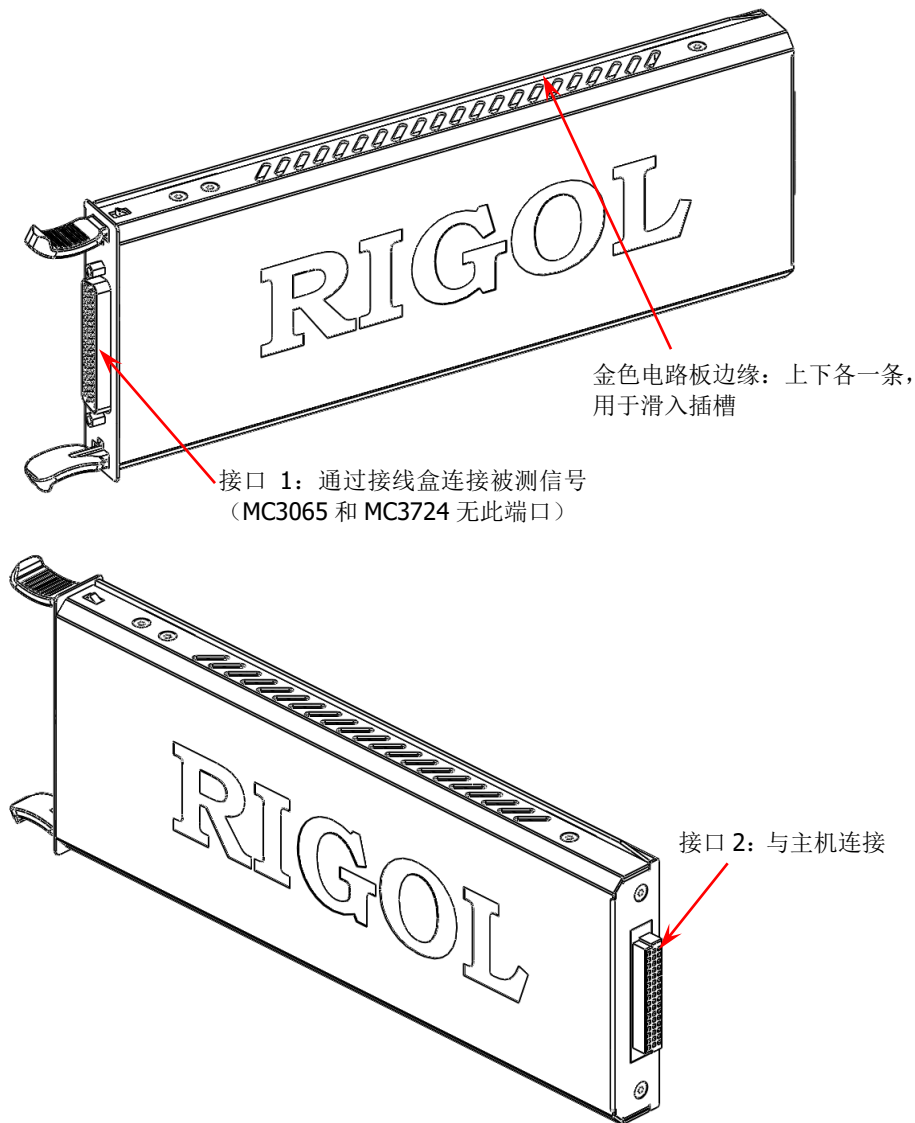
**注意：**对于需要连接被测信号的模块，将之插入主机之前，请先参考“测量连接”一节连接外部接线盒和被测信号。



图 7 向主机中插入模块



### 注意

M300 的所有模块不支持热插拔。因此，向主机中插入模块之前，请首先关闭主机。

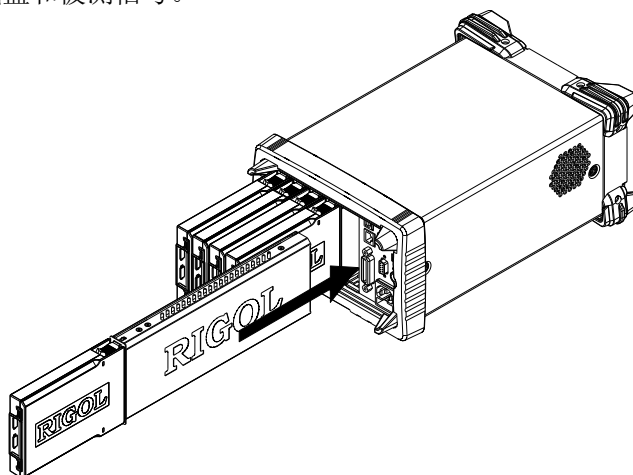
## 模块简介

### 1 MC3065 (DMM Module):

DMM 模块用于测量被测信号。6½位读数分辨率。测量功能包括直流电压、交流电压、直流电流、交流电流、二线电阻、四线电阻、频率、周期、温度以及任意传感器。

**注意：**在接入 DMM 模块后，需要确保接入模拟总线的被测信号不高于 300 Vdc 或 300 Vrms。

### 2 MC3120 和 MC3120A (20-Channel Multiplexer):

MC3120 和 MC3120A 均为 20 通道多路复用器。

20 个通道均可转换 HI 和 LO 输入，从而为 DMM 模块提供完全隔离的信号。该模块分为两排（称为 A 和 B），每排具有 10 个双线通道。当执行四线电阻测量时，A 排和 B 排的通道自动配对。已加入扫描列表的所有通道均为先断后通。当任一通道均未被添加在扫描列表时，允许闭合多个通道。

该模块可与 MC3065 (DMM Module)相连（若当前已插入 MC3065）。

有关该模块的技术指标，请查阅本产品用户手册或数据手册。

### 3 MC3132 (32-Channel Multiplexer):

32 通道多路复用器。

32 个通道均可转换 HI 和 LO 输入，从而为 DMM 模块提供完全隔离的信号。MC3132 分为两排（称为 A 和 B），每排具有 16 个双线通道。当执行四线电阻测量时，A 排和 B 排的通道自动配对。已加入扫描列表的所有通道均为先断后通。当任一通道均未被添加在扫描列表时，允许闭合多个通道。

MC3132 可与 MC3065 (DMM Module)相连（若当前已插入 MC3065）。

有关该模块的技术指标，请查阅本产品用户手册或数据手册。

### 4 MC3164 (64-Channel Single-Ended Multiplexer):

单端 64 通道多路复用器。

64 个通道均只可转换 HI 输入。MC3164 分为两排（称为 A 和 B），每排具有 32 个单端通道。已加入扫描列表的所有通道均为先断后通。任何情况下均不允许闭合多个通道。

MC3164 可与 MC3065 (DMM Module)相连（若当前已插入 MC3065）。不可用于四线电阻测量。

有关该模块的技术指标，请查阅本产品用户手册或数据手册。

### 5 MC3324 (24-Channel Multiplexer):

20 个电压通道+4 个电流通道混合多路复用器。

20 个电压通道均可转换 HI 和 LO 输入，从而为 DMM 模块提供完全隔离的输入。

20 个电压通道分为两排（称为 A 和 B），每排具有 10 个双线通道。当执行四线电阻测量时，A 排和 B 排的通道自动配对。已加入扫描列表的所有通道均为先断后通<sup>[1]</sup>。当所有通道均未被配置在扫描列表时，允许闭合多个通道。

4 个电流通道用于配合 DMM 模块执行直流电流或交流电流测量功能。已加入扫描列表的所有通道均为先断后通<sup>[1]</sup>。任何情况下均不允许闭合多个通道。MC3324 可与 MC3065 (DMM Module)相连 (若当前已插入 MC3065)。有关该模块的技术指标, 请查阅本产品用户手册或数据手册。

**注<sup>[1]</sup>:** 先断后通, 即每次仅允许一个通道闭合。对于电压通道 (通道 1 至通道 20), 扫描过程中总是先断开前一通道与 DMM 模块的连接, 再闭合下一通道与 DMM 模块的连接; 对于电流通道 (即通道 21 至通道 24), 扫描过程中总是先闭合前一通道的短路继电器、断开前一通道与 DMM 模块的连接, 再闭合下一通道与 DMM 模块的连接、断开下一通道的短路继电器。

## 6 MC3416 (16-Channel Actuator):

16 通道执行器。

MC3416 可将信号切换到被测设备或启动外部设备。16 通道中的每一通道可切换至常开 (Normally-Open, NO) 和常闭 (Normally-Closed, NC) 状态。有关该模块的技术指标, 请查阅本产品用户手册或数据手册。

## 7 MC3534 (Multifunction Module):

多功能模块。

3 种功能, 每种功能有 4 个通道。该模块可用于检测状态或控制外部设备, 如螺线管、功率继电器、微波开关等。您还可以在扫描过程中读取数字输入以及计数器的计数。

- 4 个 8 位数字输入/输出 (digital input/output, DIO) 端口
- 4 个计数器 (totalizer, TOT) 输入端 (前 2 个通道为 10 MHz TOT, 后 2 个通道为 100 kHz TOT), 灵敏度为 1 Vpp
- 4 个模拟输出端,  $\pm 12$  V 已校准电压

有关该模块的技术指标, 请查阅本产品用户手册或数据手册。

## 8 MC3648 (4×8 Matrix Switch):

4×8 双线矩阵开关。

MC3648 用于在测试时同时将多台仪器连接到被测设备的多个点上。您可以连接多个矩阵开关的行和列以建立较大的矩阵 (如 8×8、4×16, 最多 160 个交叉点)。32 个双线交叉点, 可以同时连接任何输入和输出组合。有关该模块的技术指标, 请查阅本产品用户手册或数据手册。

## 9 MC3724 (Dual 4-Channel RF Multiplexer)

双 4 通道射频多路复用器。

MC3724 提供两组独立的 4 通道射频多路复用器, 用于切换高频脉冲信号。

- 两组中的 4 个通道和 COM 通道具有公共接地端 (连接器外壳接地)。
- 不可同时闭合同一组中的多个通道。
- 您可以将信号直接连接至模块上的 SMB 连接器 (2 GHz 带宽), 也可以通过 SMB 转 BNC 线缆 (1 GHz 带宽) 连接信号。
- 级联多组射频多路复用器可创建具有更多通道的射频多路复用器。

## 使用内置帮助系统

M300 内置帮助系统提供前面板任一按键和菜单的帮助信息。如需获得任何前面板按键或菜单的帮助信息，请首先按下 **Help** 按键将其点亮，用户界面状态栏显示“Help”状态图标，此时，再按下您需要获得帮助的按键或菜单即可。内置帮助界面如下图所示，按 **确定** 退出内置帮助系统。



图 8 内置帮助系统示意图



## 菜单快速导航

本节提供 M300 主要操作菜单的结构图，旨在指导用户快速了解 M300 的操作方法，更多详细信息，请查阅本产品用户手册。

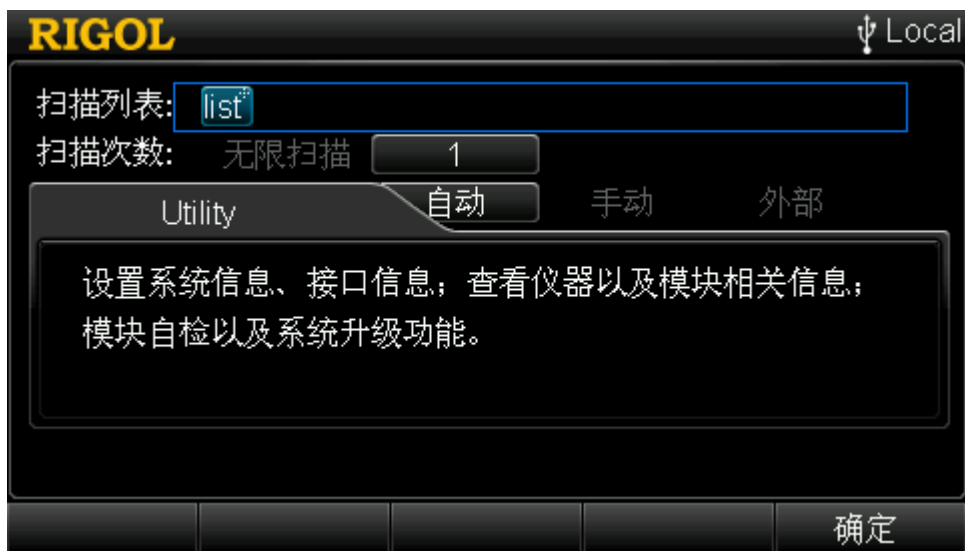
### Config

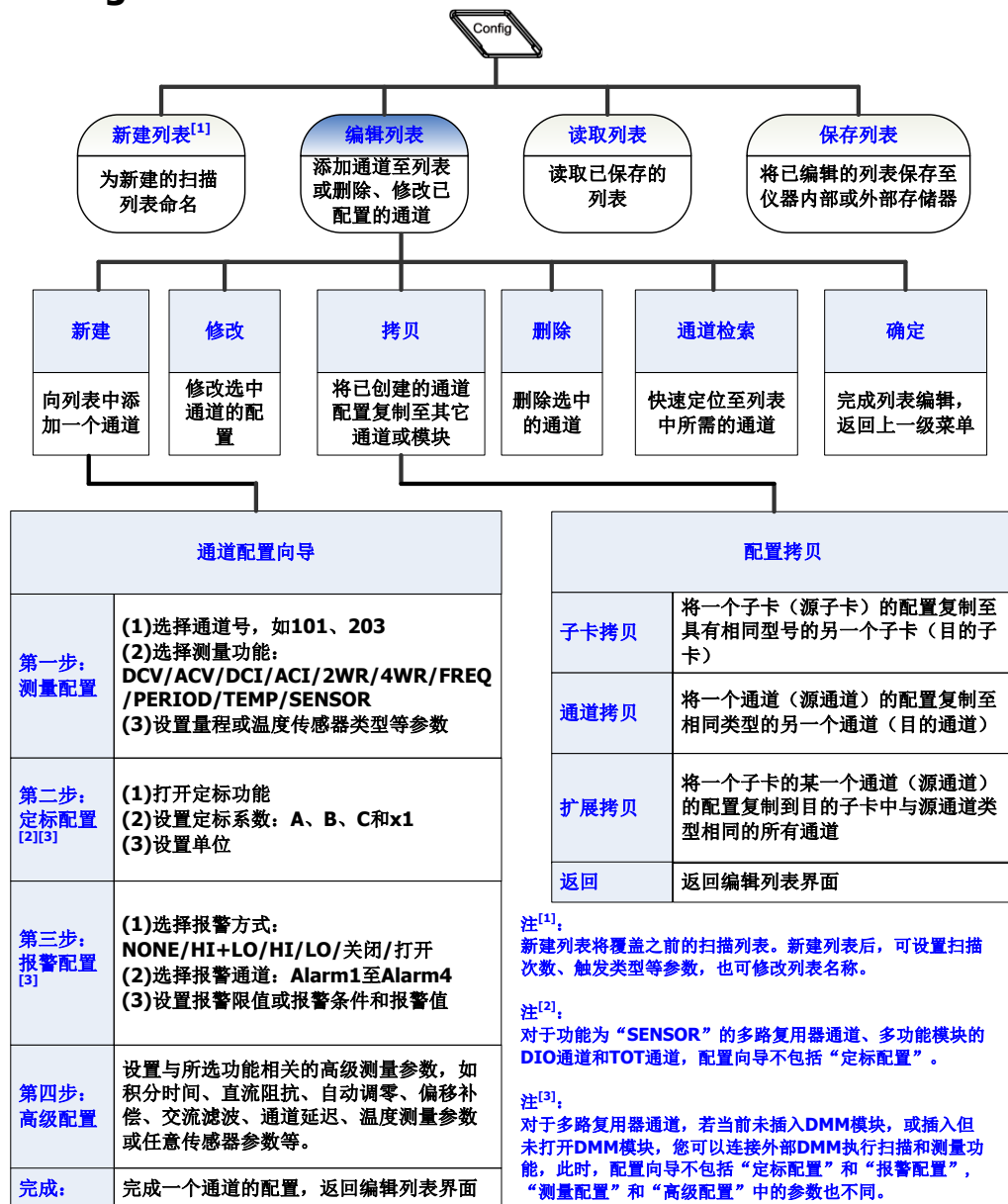

# Monitor

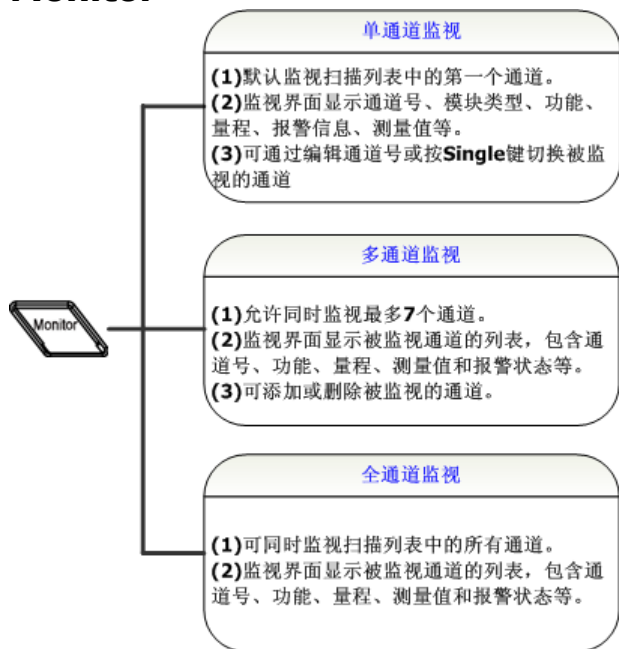

## 视图切换键

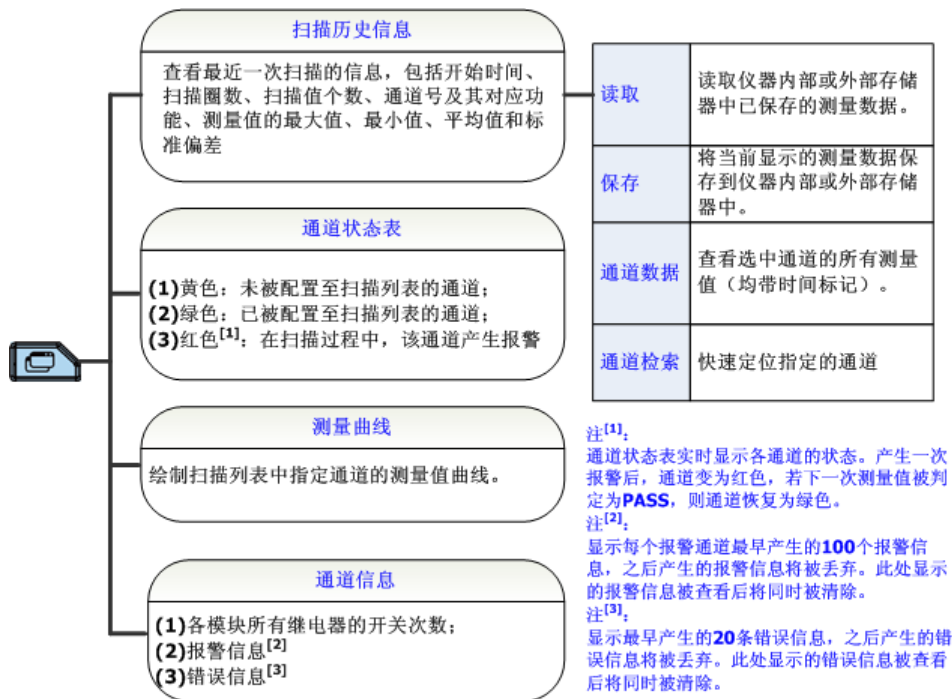

## Control

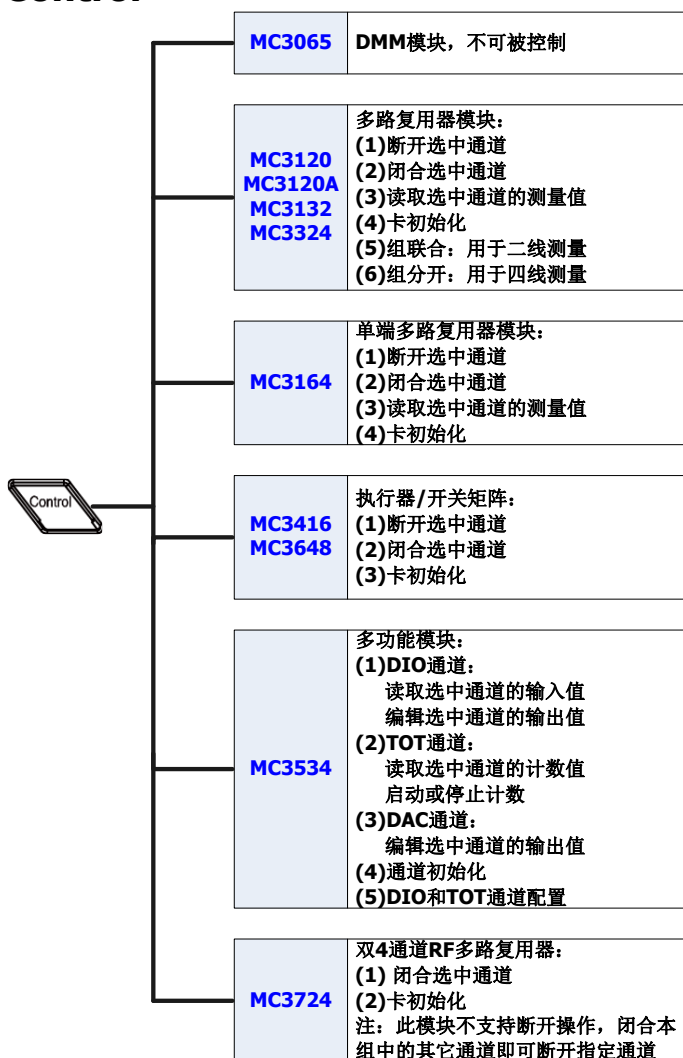

## 报警通道设置键

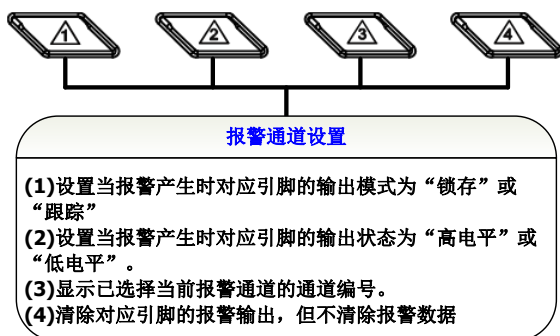

## 基本操作

本部分介绍 M300 的基本操作，包括如何连接被测信号、配置扫描列表、远程控制仪器的方法。

### 测量连接

多个被测信号通过外部接线盒被连接至插入式模块，进而被接入 DMM 模块或外部 DMM。M300 提供 9 种规格的外部接线盒。接线盒的型号及其适用的模块如下表所示。本节介绍如何通过外部接线盒连接被测信号。

**注意：**MC3724 无对应接线盒。您可以将信号直接连接至模块上的 SMB 连接器，也可以通过 SMB 转 BNC 线缆连接信号。

表 1 外部接线盒

	外部接线盒型号	适用的模块型号
1	M3TB20	MC3120
2	M3TB20A	MC3120A
3	M3TB32	MC3132
4	M3TB32T	MC3132
5	M3TB64	MC3164
6	M3TB24	MC3324
7	M3TB48	MC3648
8	M3TB16	MC3416
9	M3TB34	MC3534



#### 警告

务必断开所有电源后，才可以打开接线盒或使接线盒脱离模块。

- 1 将接线盒正面（带有 **RIGOL**）朝下，按下图箭头所示方向同时扳动两个卡勾向下压。将接线盒正面朝上，揭起接线盒上盖后拆掉。

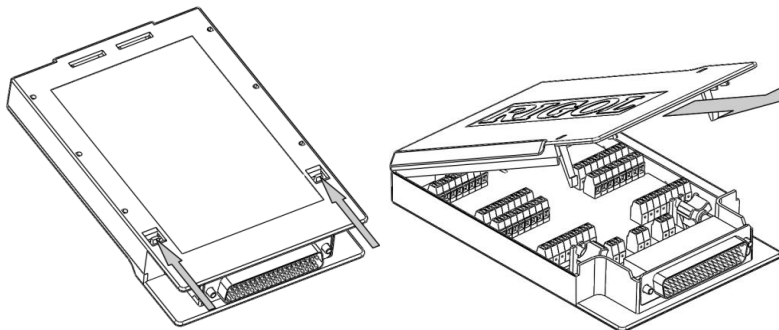

- 2 按照接线盒电路板上的标识分别连接用于连接被测信号的电缆（连接方式见表 2）。下图中箭头所示的两组孔用于穿过扎线带以固定所连接的电缆。请注意电缆连接的通道或端子以保证接入正确的信号。

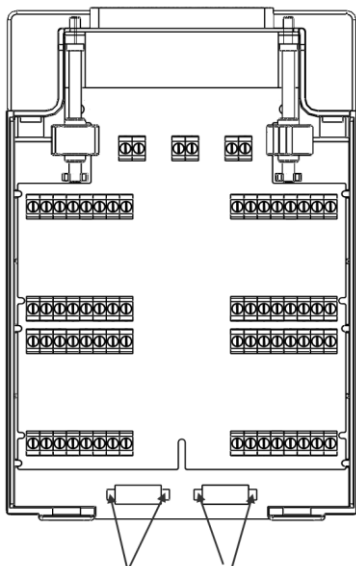

**注意：**

- 关于各模块及其对应接线盒的具体连线方式以及对连接线规格的要求，请登录 **RIGOL** 网站（[www.rigol.com](http://www.rigol.com)）查阅更多相关资料。
- 当使用多路复用器模块进行测量时，应保证被测信号的幅值以及存在的共模电压均不超过模块的最大输入电压。
- 为避免损坏继电器，在使用多路复用器模块测量具有高功率输出能力的被测对象（如电池或电源等）时，建议在接线时串联保险丝（如下图所示）。



表 2 测量连接

<p><b>DCV/ACV/频率/周期/任意传感器 (DCV、FREQ)</b></p> <p>H L CH1</p>	<p><b>DCI/ACI/任意传感器 (DCI)</b></p> <p>H L CH21</p> <p>注：仅适用于 MC3324 的通道 21 至通道 24。</p>
<p><b>2WR/RTD/热敏电阻/任意传感器 (2WR)</b></p> <p>H L CH1</p>	<p><b>4WR/RTD 4W/任意传感器 (4WR)</b></p> <p>H L Source CH1</p> <p>H L Sense CH17</p> <p>注：适用于 MC3132 的通道 1 至通道 32。</p>
<p><b>热电偶</b></p>	

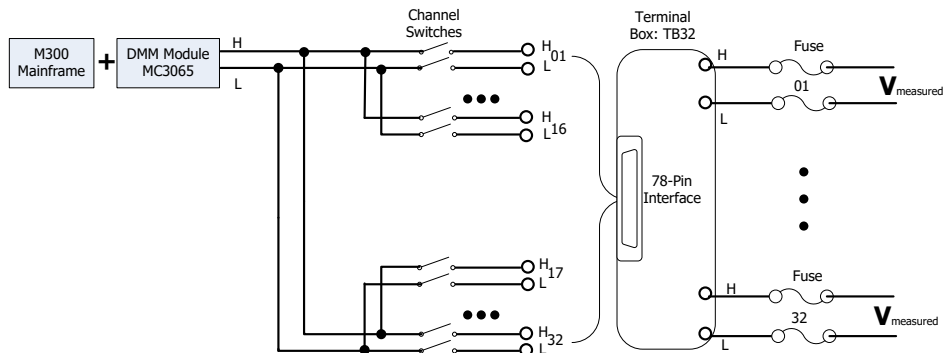
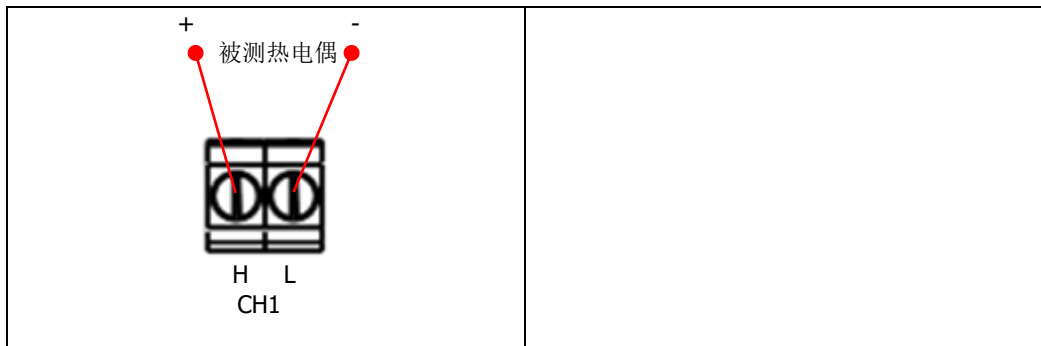

### 警告

为防止电击，测量电缆需要符合最高耐压要求。为防止损害模块，确保任何输入信号在其所标称的额定输入范围之内。

- 3 将接线盒与模块上的接口 1（接口定义见图 6）对接，旋紧两个螺杆使之与模块上的螺母紧固。

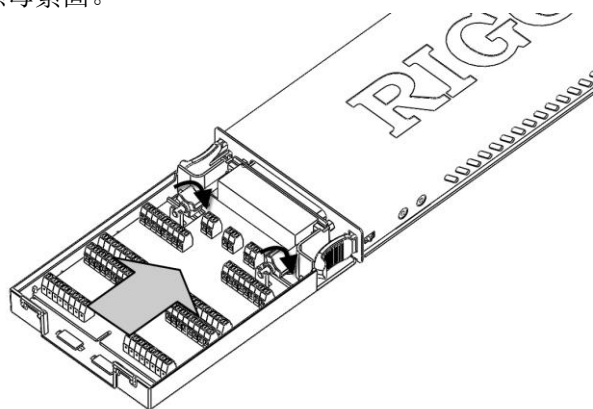

- 4 扣上接线盒上盖。

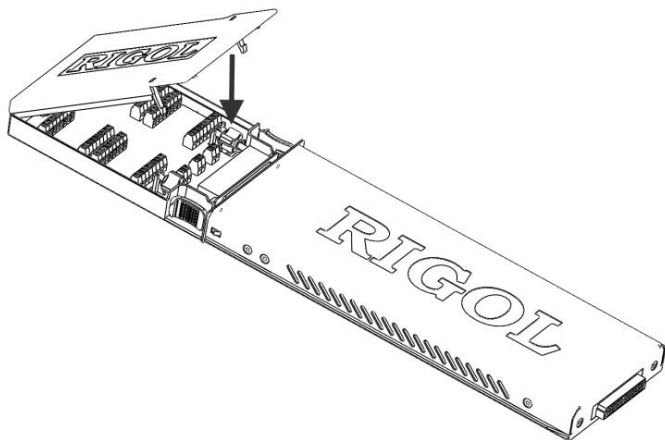

- 5 将已连接接线盒的模块插入主机插槽。

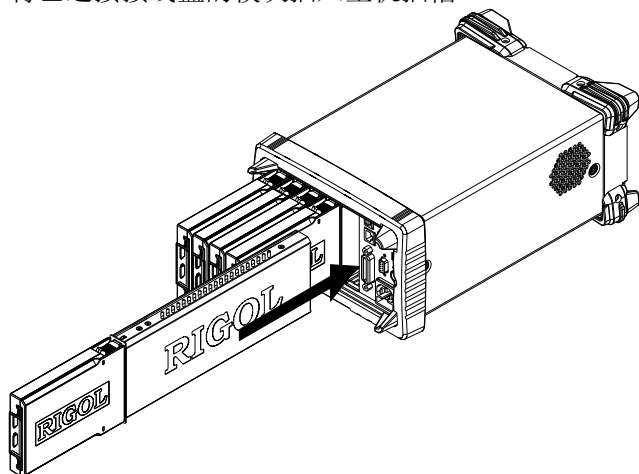

## 配置扫描列表

创建一个扫描列表，将多路复用器的任意通道或多功能模块的 DIO 或 TOT 通道添加到扫描列表，并为每个通道配置基本测量、定标、报警和高级测量参数。编辑完成的扫描列表可以存储至内部或外部存储器，并可在需要使用时调用。

### 1 新建列表

按 **Config** → **新建列表**，输入所需的列表名称按 **确认** 软键完成命名。

**注意：**新建列表后，原扫描列表将被覆盖。

### 2 设置扫描参数

- (1) 选中 **扫描次数** 项，使用左右方向键选择“无限扫描”或“1”（需设置一个扫描次数值，可设置范围为 1 至 50000）。
- (2) 选中 **触发模式** 项，使用左右方向键选择“自动”、“手动”、“外部”、“绝对时间”或“报警”。
- (3) 若选择“自动”触发模式，请选中 **间隔时间** 项，使用数字键盘设置所需的间隔时间。可设置范围为 00:00:00.000 至 99:59:59.999（时间格式为小时:分:秒.毫秒），默认为 0。  
若选择“外部”触发模式，请选中 **边沿类型** 项，使用左右方向键选择“上升沿”或“下降沿”。  
若选择“绝对时间”触发模式，请选中 **绝对时间** 项，使用数字键盘设置所需的时间。时间格式为“月-日 时:分:秒”。  
若选择“报警”触发模式，请选中 **报警通道** 项，使用左右方向键选择报警通道为“Alarm1”、“Alarm2”、“Alarm3”或“Alarm4”。

### 3 配置一个通道至扫描列表（以 DCV 功能为例）

按 **Config** → **编辑列表** → **新建**，进入通道配置向导。



(1) 第一步：测量配置

选中 **通道号** 项，使用左右方向键或数字键盘选择所需的通道号（如 101）；  
选中 **测量功能** 项，使用左右方向键选择所需的功能（DCV）；  
选中 **量程** 项，使用左右方向键选择所需的量程（如 2V）。

**注意：** 此处需要设置的参数取决于您所选择的测量功能。

(2) 第二步：定标配置

选中 **定标配置** 项，使用左右方向键打开定标配置；  
分别选中 **A**、**B** 和 **C**，使用数字键盘设置所需的定标系数；  
选中 **x1**，按 **当前值** 获取 x1。  
选中 **单位** 项，输入所需的单位。

**注意：** 对于功能为“SENSOR”的多路复用器通道、多功能模块的 DIO 通道和 TOT 通道，配置向导不包括定标配置。另外，对于多路复用器通道，若当前未插入 DMM 模块或插入但未打开 DMM 模块，连接外部 DMM 执行扫描和测量时，配置向导也不包括“定标配置”。

(3) 第三步：报警配置

选中 **报警方式** 项，使用左右方向键选择所需的报警方式（如 HI）；  
选中 **报警通道** 项，使用左右方向键选择所需的报警通道（如 Alarm1）；  
选中 **HI** 或 **LO** 项，使用数字键盘设置所需的报警限值（如 12）；

**注意：** 对于多路复用器通道，若当前未插入 DMM 模块或插入但未打开 DMM 模块，连接外部 DMM 执行扫描和测量时，配置向导不包括“报警配置”。

(4) 第四步：高级配置

选中 **积分时间** 项，使用左右方向键选择所需的积分时间（如 1PLC）；  
选中 **输入阻抗** 项，使用左右方向键选择 10MΩ 或 >10GΩ；  
选中 **AZ** 项，使用左右方向键选择“打开”或“关闭”；  
选中 **延迟** 项，使用左右方向键选择“自动”或手动设置一个延迟时间；

**注意：** 此处需要设置的参数取决于您所选择的测量功能。

按 **完成**，通道配置向导结束，返回扫描列表编辑界面。

#### 4 配置其它通道至扫描列表

按 **新建** 并按照步骤 3 将其它通道配置至扫描列表。

#### 5 保存扫描列表

扫描列表配置完成后，您可以按 **保存列表** 将已配置的扫描列表保存到仪器内部或外部存储器中。

## 配置拷贝

M300 提供配置拷贝功能（模块拷贝、通道拷贝和扩展拷贝），可用于快速将具有相同配置的通道配置至扫描列表。

按 **Config** → **编辑列表** → **拷贝**，进入配置拷贝界面。

### 1 模块拷贝：

可将一个模块（源模块）的配置复制至具有相同型号的另一个模块（目的模块）。完成模块拷贝后，源模块各通道的配置情况被自动复制至目的模块。

在配置拷贝界面中，按 **模块拷贝** 软键，打开模块拷贝界面。

(1) 默认选中“源模块”区，使用上下方向键选择所需的源模块。

(2) 按 **切换** 将光标切换至“目的模块”区，使用上下方向键选择所需的目的模块。

(3) 按 **确定** 执行模块拷贝。

**注意：**所选的源模块和目的模块必须具有相同的型号，且不允许对同一模块执行拷贝操作。

### 2 通道拷贝：

可将一个通道（源通道）的配置复制至相同类型的另一个或多个通道（目的通道）。

在配置拷贝界面中，按 **通道拷贝** 软键，打开通道拷贝界面。默认将所选通道固定为源通道且选中上区域，此时，使用左右方向键选择所需的目的通道，然后按 **OK** 键选中目的通道（再次按 **OK** 键取消选中），按 **完成** 执行通道拷贝。

打开通道拷贝界面后，您也可以按 **切换**，将所选通道固定为目的通道。此时，下区域被选中，使用左右方向键选择所需的源通道，按 **完成** 执行通道拷贝。

**提示：**

(1) 固定所选通道为源通道时，允许选择多个目的通道。所选的目的通道显示在界面的下区域。

(2) 固定所选通道为目的通道时，只允许选择一个源通道。

(3) 若当前扫描列表仅有一个通道，则 **切换** 置灰禁用。

**注意：**通道拷贝，只允许同一类型通道间的拷贝，即属于同一类型模块的通道。

### 3 扩展拷贝：

可将一个模块的某一个通道（源通道）的配置复制到目的模块中与源通道类型相同的所有通道。

在配置拷贝界面中，按 **扩展拷贝** 软键，进入扩展拷贝界面。

- (1) 默认选中“源通道”区，使用方向键选择所需的源通道。
- (2) 按 **切换** 将光标切换至“目的模块”区，使用上下方向键选择所需的模块。
- (3) 按 **确定** 执行扩展拷贝。

**注意：**扩展拷贝，只允许同一类型模块间的复制。该功能便于配置多个相同的测量通道。

## 通道监视

M300 通道监视功能可监视单通道、扫描列表中的多个通道或全部通道。无论当前是否处于扫描过程中，仪器对通道进行连续监视，不断从被监视通道读取读数。该功能对于在测试前排除系统故障或观测重要信号有极大作用。

通道监视功能可监视如下通道：多路复用器通道（已配置到扫描列表且 DMM 模块已打开）、多功能模块的 DIO 通道和 TOT 通道（无论是否配置到扫描列表，均可监视，且 DMM 模块不必打开）。按前面板 **Monitor** 键，您可以配置通道监视功能。

### 1 单通道监视

按 **Monitor** → **单通道**，进入单通道监视界面，默认监视扫描列表中的第一个通道。若当前没有配置扫描列表，则监视多功能模块的第 1 个通道（DIO 通道）。单通道监视功能只允许在同一时间监视一个通道。您可以随时更改被监视的通道。监视过程中，仪器仅显示但不存储读数。报警功能应用于被监视通道时，所有报警数据存储在报警队列中（仪器断电时清除数据）。欲监视多路复用器通道，需确保 DMM 模块安装并打开（**Utility** → **DMM** → “开”）且被监视的通道已加入扫描列表。允许监视未加入扫描列表的 DIO 通道和 TOT 通道。

### 2 多通道监视

按 **Monitor** → **多通道**，进入多通道监视界面。多通道监视允许监视最多 7 个通道。您可以添加或删除被监视的通道。

### 3 全通道监视

按 **Monitor** → **全通道**，进入全通道监视界面。全通道监视可以监视扫描列表中的所有通道。

## 远程控制

M300 支持通过 USB、LAN、GPIB 或 RS232（由后面板的 **[RS-232/Alarms/Ext Trig]** 接口转换）接口与计算机进行通信从而实现远程控制。远程控制基于 SCPI 命令集（Standard Commands for Programmable Instruments）实现。本节将介绍如何使用 RIGOL 提供的通用 PC 软件 Ultra Sigma 发送 SCPI 命令并通过 USB 接口对仪器进行

远程控制。有关命令的详细说明请参考本产品编程手册。

## 1 安装 Ultra Sigma 软件

登陆 **RIGOL** 网站 ([www.rigol.com](http://www.rigol.com)) 下载 Ultra Sigma 软件，然后按照指导正确安装。

## 2 通过 USB 控制

### (1) 连接设备

使用 USB 数据线连接 M300 (USB Device) 与计算机 (USB Host)。

### (2) 安装 USB 驱动

本仪器为 USB-TMC 设备，将仪器与 PC 正确连接并开机后，PC 将弹出硬件更新向导对话框，请按照向导的提示安装“USB Test and Measurement Device (IVI)”驱动程序。

### (3) 搜索设备资源

打开 Ultra Sigma，软件将自动搜索当前连接到计算机上的仪器资源，您也可以点击 **USB-TMC** 进行搜索。

### (4) 查看设备资源

搜索到的资源将出现在“RIGOL Online Resource”目录下，并且显示仪器的型号和 USB 接口信息，如下图所示：





图 9 查看 USB 仪器资源

### (5) 发送命令/读取数据

右击资源名“M300 (USB0::0x1AB1::0x0C80::M300123123123::INSTR)”，选择“SCPI Panel Control”，打开远程命令控制面板，即可通过该面板发送命令和读取数据。

### 说明：

当仪器工作在远程模式时，用户界面状态栏显示 Rmt，前面板按键被锁定（除外）。此时，您可以按  键退出远程模式。

# 故障处理

当您遇到如下问题时，请按照相应的步骤处理。若问题依然存在，请与 **RIGOL** 联系，同时请提供机器的系统信息（获取方法：**Utility** → **信息**）。

## 1 无法开机？

- 1) 检查电源线是否已正确连接。
- 2) 检查前面板电源开关是否已经打开。
- 3) 拔掉电源线，检查电压选择器是否处于正确的档位，电源输入保险丝是否已经熔断。如果已经熔断，请按要求更换保险丝。
- 4) 做完上述检查后，重新启动仪器。
- 5) 如果故障仍然存在，请与 **RIGOL** 联系。

## 2 U 盘不能被识别？

- 1) 检查 U 盘是否可以正常工作。
- 2) 确认使用的为 FAT32 格式闪存型 U 盘。
- 3) 重新启动仪器，再插入 U 盘进行检查。
- 4) 如果仍然无法正常使用 U 盘，请与 **RIGOL** 联系。



## 3 如果测量过程中发生断电或意外关机，如何恢复断电之前的配置并自动继续关机之前的工作？

重启机器。按 **Utility** → **System**，使用上下方向键选中 **掉电配置** 项，使用左右方向键选择“开”。

## 4 屏幕显示太暗？

按 **Utility** → **System**，使用上下方向键选中 **亮度** 项，使用左右方向键将亮度调整到合适的状态。

## 5 仪器被锁定？

- 1) 检查仪器是否工作在远程模式：仪器工作在远程模式时，用户界面状态栏显示“Rmt”，此时，按  键可退出远程模式，解锁前面板。
- 2) 检查仪器前面板是否被锁定：仪器前面板被锁定时，用户界面状态栏显示 ，此时，长按  键可解锁前面板。
- 3) 检查界面是否显示进度条：等待进度条消失后重试。
- 4) 如果故障仍然存在，重新启动仪器可解除锁定。

## 6 如何切换系统语言？

按 **Utility** → **System**，使用上下方向键选中 **Language** 项，使用左右方向键选择所需的系统语言。

## 7 如何查看插入式模块的信息与型号？

按 **Utility** → **检测**，使用左右方向键选择所需查看的模块，按 **查看** 菜单即可查看模块的信息与型号。

**8 插入模块后，对应插槽的模块指示灯没有点亮？**

- 1) 按 **Utility** → **检测**，使用左右方向键选择该模块，按 **重检模块**。
- 2) 若问题依然存在，请按 **查看**。如果无法查看，请参考故障 9 解决；
- 3) 如果可以查看，则判定为模块指示灯损坏，请与 **RIGOL** 联系咨询维修事宜。

**9 插入模块后，无法查看模块信息或无法使用该模块？**

- 1) 关机，拔掉模块，重新安装模块并确保安装可靠稳定。
- 2) 重启主机，等待 1 分钟，重试查看模块信息。
- 3) 如果故障仍然存在，请与 **RIGOL** 联系。

**10 插入 DMM 模块，但是无法执行与 DMM 模块相关的配置或操作？**

- 1) 确保 **Utility** → **System** → **DMM** 项的设置为“开”。
- 2) 按 **Utility** → **检测**，使用左右方向键选择 DMM 模块，按 **查看** 菜单查看 DMM 模块信息是否正常。若无显示或不正常显示，则可能由于大电流或电源负载故障导致 DMM 模块工作异常，请关机并等待几分钟后重启。
- 3) 如果故障仍然存在，请与 **RIGOL** 联系。

**11 GPIB 接口不能正常工作？**

- 1) 检查连接线是否可以正常工作并确保连接正确可靠。
- 2) 确保 M300 的 GPIB 地址与计算机的 GPIB 地址一致。
- 3) 如果故障仍然存在，请与 **RIGOL** 联系。

**12 USB Device 接口不能正常工作？**

- 1) 检查连接线是否可以正常工作并确保连接正确可靠。
- 2) 检查您的 PC 是否正确安装“USB Test and Measurement Device (IVI)”驱动程序。
- 3) 如果故障仍然存在，请与 **RIGOL** 联系。

**13 RS232 接口不能正常工作？**

- 1) 确保仪器与计算机的 RS232 接口参数（波特率等）设置一致。
- 2) 检查 RS232 连接线是否为交叉线。
- 3) 如果故障仍然存在，请与 **RIGOL** 联系。

**14 LAN 接口不能正常工作？**

- 1) 检查连接线是否可以正常工作并确保连接正确可靠。
- 2) 检查 IP 配置模式：
  - 若 DHCP 打开，请确保当前网络支持 DHCP 配置模式并能够自动为 M300 分配 IP 地址等网络参数；
  - 若 DHCP 关闭，自动 IP 打开，请检查 M300 自动获取的 IP 地址与计算机的网络参数是否处于同一网段；
  - 若仅手动 IP 打开，请确保 M300 与计算机的网络参数设置处于同一网段。
- 3) 如果故障仍然存在，请与 **RIGOL** 联系。

# **RIGOL**

## **Quick Guide**

### **M300 Series**

## **Data Acquisition/Switch System**

**May, 2016**  
**RIGOL TECHNOLOGIES CO., LTD.**





# Guaranty and Declaration

## Copyright

© 2020 **RIGOL** TECHNOLOGIES CO., LTD. All Rights Reserved.

## Trademark Information

**RIGOL**® is the trademark of **RIGOL** TECHNOLOGIES CO., LTD.

## Publication Number

QGC07110-1110

## Notices

- **RIGOL** products are covered by P.R.C. and foreign patents, issued and pending.
- **RIGOL** reserves the right to modify or change parts of or all the specifications and pricing policies at the company's sole decision.
- Information in this publication replaces all previously released materials.
- Information in this publication is subject to change without notice.
- **RIGOL** shall not be liable for either incidental or consequential losses in connection with the furnishing, use, or performance of this manual, as well as any information contained.
- Any part of this document is forbidden to be copied, photocopied, or rearranged without prior written approval of **RIGOL**.

## Product Certification

**RIGOL** guarantees that this product conforms to the national and industrial standards in China as well as the ISO9001:2015 standard and the ISO14001:2015 standard. Other international standard conformance certifications are in progress.

## Contact Us

If you have any problem or requirement when using our products or this manual, please contact **RIGOL**.

E-mail: [service@rigol.com](mailto:service@rigol.com)

Website: [www.rigol.com](http://www.rigol.com)

# Safety Requirement

## General Safety Summary

Please review the following safety precautions carefully before putting the instrument into operation so as to avoid any personal injury or damage to the instrument and any product connected to it. To prevent potential hazards, please follow the instructions specified in this manual to use the instrument properly.

### **Use Proper Power Cord.**

Only the exclusive power cord designed for the instrument and authorized for use within the local country could be used.

### **Ground the Instrument.**

The instrument is grounded through the Protective Earth lead of the power cord. To avoid electric shock, connect the earth terminal of the power cord to the Protective Earth terminal before connecting any input or output terminals.

### **Connect the Probe Correctly.**

If a probe is used, the probe ground lead must be connected to earth ground. Do not connect the ground lead to high voltage. Improper way of connection could result in dangerous voltages being present on the connectors, controls or other surfaces of the oscilloscope and probes, which will cause potential hazards for operators.

### **Observe All Terminal Ratings.**

To avoid fire or shock hazard, observe all ratings and markers on the instrument and check your manual for more information about ratings before connecting the instrument.

### **Use Proper Overvoltage Protection.**

Ensure that no overvoltage (such as that caused by a bolt of lightning) can reach the product. Otherwise, the operator might be exposed to the danger of an electric shock.

### **Do Not Operate Without Covers.**

Do not operate the instrument with covers or panels removed.

### **Do Not Insert Anything into the Air Outlet.**

Do not insert anything into the air outlet to avoid damage to the instrument.

### **Use Proper Fuse.**

Please use the specified fuses.

### **Avoid Circuit or Wire Exposure.**

Do not touch exposed junctions and components when the unit is powered on.

### **Do Not Operate with Suspected Failures.**

If you suspect that any damage may occur to the instrument, have it inspected by

**RIGOL** authorized personnel before further operations. Any maintenance, adjustment or replacement especially to circuits or accessories must be performed by **RIGOL** authorized personnel.

**Provide Adequate Ventilation.**

Inadequate ventilation may cause an increase of temperature in the instrument, which would cause damage to the instrument. So please keep the instrument well ventilated and inspect the air outlet and the fan regularly.

**Do Not Operate in Wet Conditions.**

To avoid short circuit inside the instrument or electric shock, never operate the instrument in a humid environment.

**Do Not Operate in an Explosive Atmosphere.**

To avoid personal injuries or damage to the instrument, never operate the instrument in an explosive atmosphere.

**Keep Instrument Surfaces Clean and Dry.**

To avoid dust or moisture from affecting the performance of the instrument, keep the surfaces of the instrument clean and dry.

**Prevent Electrostatic Impact.**

Operate the instrument in an electrostatic discharge protective environment to avoid damage induced by static discharges. Always ground both the internal and external conductors of cables to release static before making connections.

**Use the Battery Properly.**

Do not expose the battery (if available) to high temperature or fire. Keep it out of the reach of children. Improper change of a battery (lithium battery) may cause an explosion. Use the **RIGOL** specified battery only.

**Handle with Caution.**

Please handle with care during transportation to avoid damage to keys, knobs, interfaces, and other parts on the panels.

# Safety Notices and Symbols

## Safety Notices in this Manual:



---

**WARNING**

Indicates a potentially hazardous situation or practice which, if not avoided, will result in serious injury or death.

---



---

**CAUTION**

Indicates a potentially hazardous situation or practice which, if not avoided, could result in damage to the product or loss of important data.

---

## Safety Terms on the Product:

**DANGER** It calls attention to an operation, if not correctly performed, could result in injury or hazard immediately.

**WARNING** It calls attention to an operation, if not correctly performed, could result in potential injury or hazard.

**CAUTION** It calls attention to an operation, if not correctly performed, could result in damage to the product or other devices connected to the product.

## Safety Symbols on the Product:



Hazardous Voltage



Safety Warning



Protective Earth Terminal



Chassis Ground



Test Ground

## Allgemeine Sicherheits Informationen

Überprüfen Sie die folgenden Sicherheitshinweise sorgfältig um Personenschäden oder Schäden am Gerät und an damit verbundenen weiteren Geräten zu vermeiden. Zur Vermeidung von Gefahren, nutzen Sie bitte das Gerät nur so, wie in diesem Handbuch angegeben.

### **Um Feuer oder Verletzungen zu vermeiden, verwenden Sie ein ordnungsgemäßes Netzkabel.**

Verwenden Sie für dieses Gerät nur das für ihr Land zugelassene und genehmigte Netzkabel.

### **Erden des Gerätes.**

Das Gerät ist durch den Schutzleiter im Netzkabel geerdet. Um Gefahren durch elektrischen Schlag zu vermeiden, ist es unerlässlich, die Erdung durchzuführen. Erst dann dürfen weitere Ein- oder Ausgänge verbunden werden.

### **Anschluss eines Tastkopfes.**

Die Erdungsklemmen der Sonden sind auf dem gleichen Spannungspegel des Instruments geerdet. Schließen Sie die Erdungsklemmen an keine hohe Spannung an.

### **Beachten Sie alle Anschlüsse.**

Zur Vermeidung von Feuer oder Stromschlag, beachten Sie alle Bemerkungen und Markierungen auf dem Instrument. Befolgen Sie die Bedienungsanleitung für weitere Informationen, bevor Sie weitere Anschlüsse an das Instrument legen.

### **Verwenden Sie einen geeigneten Überspannungsschutz.**

Stellen Sie sicher, daß keinerlei Überspannung (wie z.B. durch Gewitter verursacht) das Gerät erreichen kann. Andernfalls besteht für den Anwender die Gefahr eines Stromschlages.

### **Nicht ohne Abdeckung einschalten.**

Betreiben Sie das Gerät nicht mit entfernten Gehäuse-Abdeckungen.

### **Betreiben Sie das Gerät nicht geöffnet.**

Der Betrieb mit offenen oder entfernten Gehäuseteilen ist nicht zulässig. Nichts in entsprechende Öffnungen stecken (Lüfter z.B.)

### **Passende Sicherung verwenden.**

Setzen Sie nur die spezifikationsgemäßen Sicherungen ein.

### **Vermeiden Sie ungeschützte Verbindungen.**

Berühren Sie keine unisolierten Verbindungen oder Baugruppen, während das Gerät in Betrieb ist.

### **Betreiben Sie das Gerät nicht im Fehlerfall.**

Wenn Sie am Gerät einen Defekt vermuten, sorgen Sie dafür, bevor Sie das Gerät wieder

betreiben, dass eine Untersuchung durch **RIGOL** autorisiertem Personal durchgeführt wird. Jedwede Wartung, Einstellarbeiten oder Austausch von Teilen am Gerät, sowie am Zubehör dürfen nur von **RIGOL** autorisiertem Personal durchgeführt werden.

**Belüftung sicherstellen.**

Unzureichende Belüftung kann zu Temperaturanstiegen und somit zu thermischen Schäden am Gerät führen. Stellen Sie deswegen die Belüftung sicher und kontrollieren regelmäßig Lüfter und Belüftungsöffnungen.

**Nicht in feuchter Umgebung betreiben.**

Zur Vermeidung von Kurzschluß im Geräteinneren und Stromschlag betreiben Sie das Gerät bitte niemals in feuchter Umgebung.

**Nicht in explosiver Atmosphäre betreiben.**

Zur Vermeidung von Personen- und Sachschäden ist es unumgänglich, das Gerät ausschließlich fernab jedweder explosiven Atmosphäre zu betreiben.

**Geräteoberflächen sauber und trocken halten.**

Um den Einfluß von Staub und Feuchtigkeit aus der Luft auszuschließen, halten Sie bitte die Geräteoberflächen sauber und trocken.

**Schutz gegen elektrostatische Entladung (ESD).**

Sorgen Sie für eine elektrostatisch geschützte Umgebung, um somit Schäden und Funktionsstörungen durch ESD zu vermeiden. Erden Sie vor dem Anschluß immer Innen- und Außenleiter der Verbindungsleitung, um statische Aufladung zu entladen.

**Die richtige Verwendung des Akku.**

Wenn eine Batterie verwendet wird, vermeiden Sie hohe Temperaturen bzw. Feuer ausgesetzt werden. Bewahren Sie es außerhalb der Reichweite von Kindern auf. Unsachgemäße Änderung der Batterie (Anmerkung: Lithium-Batterie) kann zu einer Explosion führen. Verwenden Sie nur von **RIGOL** angegebenen Akkus.

**Sicherer Transport.**

Transportieren Sie das Gerät sorgfältig (Verpackung!), um Schäden an Bedienelementen, Anschlüssen und anderen Teilen zu vermeiden.

# Sicherheits Begriffe und Symbole

## Begriffe in diesem Guide:



### **WARNING**

Die Kennzeichnung WARNING beschreibt Gefahrenquellen die leibliche Schäden oder den Tod von Personen zur Folge haben können.



### **CAUTION**

Die Kennzeichnung Caution (Vorsicht) beschreibt Gefahrenquellen die Schäden am Gerät hervorrufen können.

## Begriffe auf dem Produkt:

**DANGER** weist auf eine Verletzung oder Gefährdung hin, die sofort geschehen kann.

**WARNING** weist auf eine Verletzung oder Gefährdung hin, die möglicherweise nicht sofort geschehen.

**CAUTION** weist auf eine Verletzung oder Gefährdung hin und bedeutet, dass eine mögliche Beschädigung des Instruments oder anderer Gegenstände auftreten kann.

## Symbole auf dem Produkt:



Gefährliche Spannung



Sicherheits-Hinweis



Schutz-erde



Gehäusemasse



Erde

## Care and Cleaning

### Care

Do not store or leave the instrument where it may be exposed to direct sunlight for long periods of time.

### Cleaning

Clean the instrument regularly according to its operating conditions.

- 1 Disconnect the instrument from all power sources.
- 2 Clean the external surfaces of the instrument with a soft cloth dampened with mild detergent or water. Avoid having any water or other objects into the chassis via the heat dissipation hole. When cleaning the LCD, take care to avoid scarifying it.



#### CAUTION

To avoid damage to the instrument, do not expose it to caustic liquids.

---



#### WARNING

To avoid short-circuit resulting from moisture or personal injuries, ensure that the instrument is completely dry before connecting it to the power supply.

---

## Environmental Considerations

The following symbol indicates that this product complies with the WEEE Directive 2002/96/EC.



### Product End-of-Life Handling

The equipment may contain substances that could be harmful to the environment or human health. To avoid the release of such substances into the environment and avoid harm to human health, we recommend you to recycle this product appropriately to ensure that most materials are reused or recycled properly. Please contact your local authorities for disposal or recycling information.

You can click on the following link <https://int.rigol.com/services/declaration.html> to download the latest version of the RoHS&WEEE certification file.



# Contents

<b>Guaranty and Declaration</b> .....	<b>I</b>
<b>Safety Requirement</b> .....	<b>II</b>
General Safety Summary.....	II
Safety Terms and Symbols.....	IV
Allgemeine Sicherheits Informationen.....	V
Sicherheits Begriffe und Symbole .....	VII
General Care and Cleaning .....	VIII
Environmental Considerations .....	VIII
<b>Document Overview</b> .....	<b>1</b>
<b>Quick Start</b> .....	<b>1</b>
General Inspection.....	1
Appearance and Dimensions.....	2
Front Panel .....	3
Rear Panel .....	7
Power On and Inspection .....	11
User Interface .....	12
Plug-in Module Overview .....	13
Outside View drawing of the module.....	13
Insert the Module into the Mainframe .....	14
Module Overview .....	15
To Use the Built-in Help System .....	17
Menu Quick Navigation.....	18
Config .....	18
Monitor .....	19
View Switch Key.....	19
Control.....	20
Alarm Channel Setting Keys .....	20
<b>Basic Operations</b> .....	<b>21</b>
Measurement Connections.....	21
To Configure Scan List.....	26
Configuration Copy .....	28
Channel Monitor .....	29
Remote Control .....	30
<b>Troubleshooting</b> .....	<b>32</b>



---

# Document Overview

This manual briefly introduces the front and rear panels, the user interface and the basic measurement method of M300 Series Data Acquisition/Switch System. It guides users to quickly get familiar with the instrument. For more detailed information, please refer to the User Guide.

## Quick Start

This section provides the basic information about the front and rear panels, the user interface and the plug-in modules.

## General Inspection

### 1 Inspect the packaging

If the packaging has been damaged, do not dispose the damaged packaging or cushioning materials until the shipment has been checked for completeness and has passed both electrical and mechanical tests.

The consigner or carrier shall be liable for the damage to the instrument resulting from shipment. **RIGOL** would not be responsible for free maintenance/rework or replacement of the instrument.

### 2 Inspect the instrument

In case of any mechanical damage, missing parts, or failure in passing the electrical and mechanical tests, contact your **RIGOL** sales representative.

### 3 Check the accessories

Please check the accessories according to the packing lists. If the accessories are damaged or incomplete, please contact your **RIGOL** sales representative.

# Appearance and Dimensions

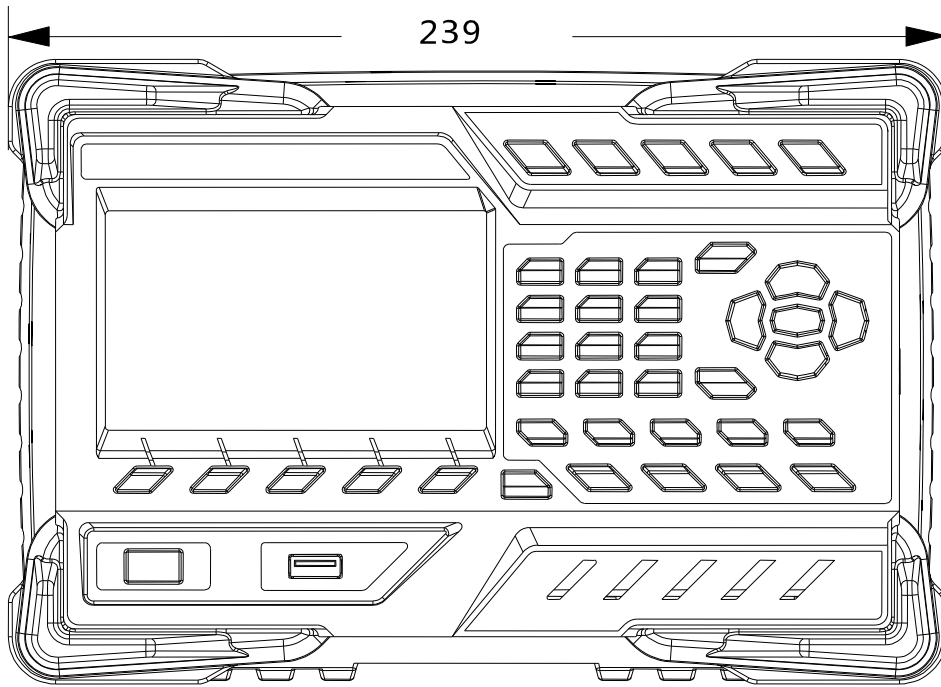

Figure 1 Front View

Unit: mm

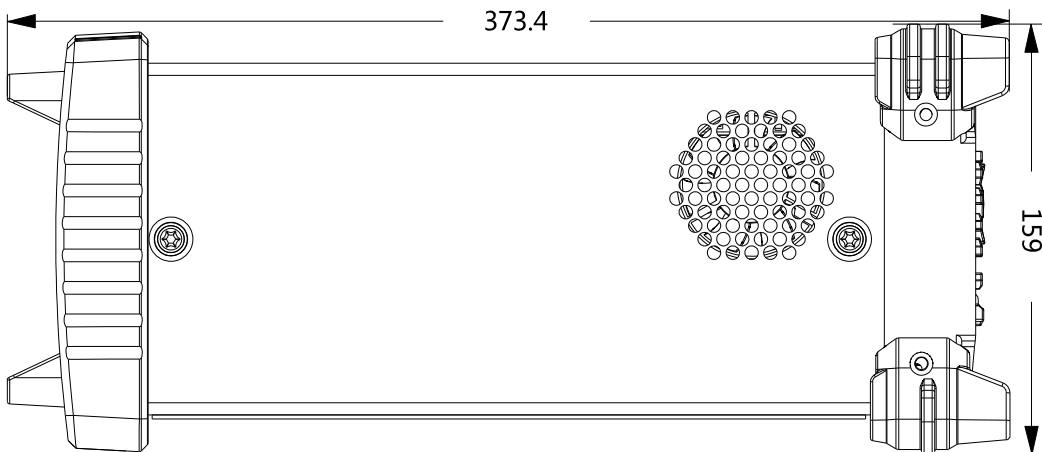

Figure 2 Side View

Unit: mm

# Front Panel

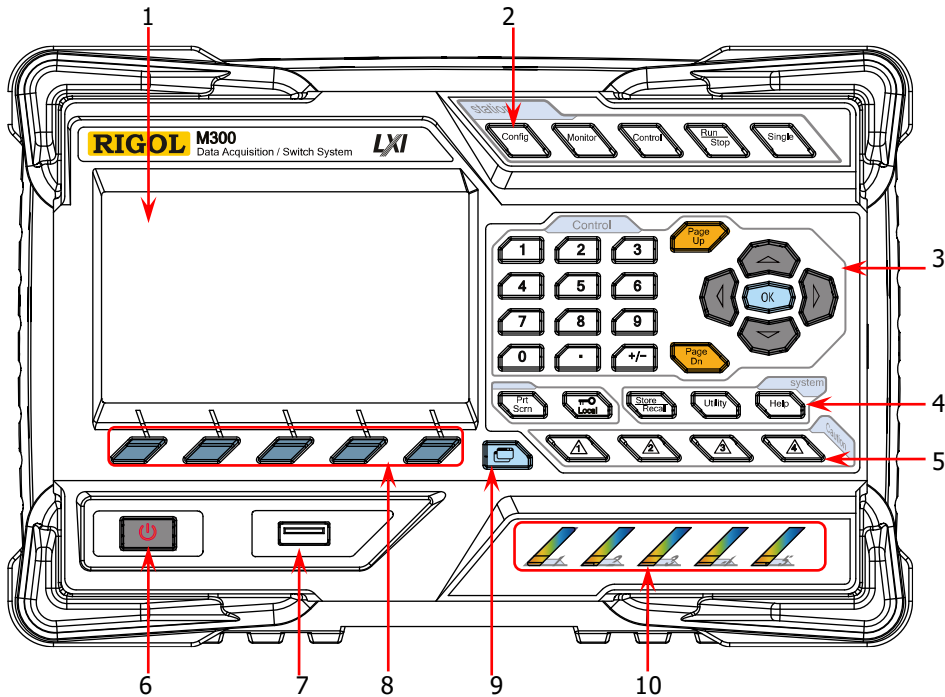

Figure 3 M300 Front Panel

## 1 LCD

4.3-inch high-resolution color LCD. It displays the menu, configuration guide, measurement parameters, system status, prompt messages and etc.

## 2 Function Keys



Configure the scan list and the measurement parameters of each channel.

- Create, edit, read and save the scan list.
- Set the number of scans, trigger mode and scan interval.
- Provide the channel configuration guide which can be used to configure the measurement parameters, scaling parameters, alarm parameters and advanced measurement parameters of the channel.



Enable or disable the channel monitor function.

- Support single-channel, multi-channel and all-channel monitor functions.
- In single-channel monitor function, you can switch the channel monitored at any time.
- In multi-channel monitor function, you can monitor up to 7 channels in the scan list.

- In all-channel monitor function, you can monitor all the channels in the scan list.



Control the modules currently inserted.

- Control the status of each channel of the modules.
- Initialize the modules.
- Configure the channels of the multifunction module.
- Cannot control the DMM module.



Auto Trigger/Stop

Press this key, the instrument triggers or enters the wait-for-trigger state and the backlight of the key goes on. At this point, press and hold this key; the instrument stops triggering or exits the wait-for-trigger state and the backlight of the key goes off.

**Note:** This key is invalid when the scan list is empty.



Single-channel Switch

When the instrument is in the single-channel monitor interface, pressing this key can switch the channel monitored to the next channel in the scan list; when the instrument is in other interfaces, pressing this key can switch the instrument to the single-channel monitor interface.

### 3 Control Keys

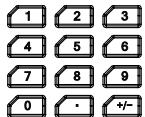

Numeric Keyboard

- Include numbers (0-9), decimal point (.), as well as positive/negative sign (+/-).
- Used to input parameter value, date and time.



Open the previous or next page of the current interface.

**Note:** These keys are different from the menu page up/down keys (**Page Up** and **Page Dn**).

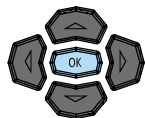

Arrow keys and confirmation key.

### 4 System Keys



If a USB storage device is currently connected to the instrument, pressing this key will store the current content on the screen in the USB storage device in \*.bmp format.

**Note:** Only the FAT32 format flash memory USB storage device is supported.



- When the instrument is in local mode, pressing this key can lock the front panel. At this point, all the keys on the front panel except this key become invalid. Pressing and holding this key can unlock the front panel.
- When the instrument is in remote mode, pressing this key can switch to local mode.



Store and recall the system configuration, measurement configuration, measurement data and etc.

- Store the file in the internal non-volatile memory or external USB storage device.
- Read the file stored.



Configure the system-related parameters.

- Set various parameters such as the time, date, system language and display brightness.
- Configure the remote interface (RS232, LAN, GPIB and USB) parameters.
- Query the system information (such as the model and serial number).
- Execute self-test and view the information of each module (such as the name and model of the module).
- System update.



Enable the built-in help system. Provide Chinese/English help information for the front panel function keys and menu items.

## 5 Alarm Channel Setting



M300 provides 4 alarm channels. When an alarm is generated, the corresponding pin of the Alarms/Ext Trig interface (converted from the **[RS-232/Alarms/Ext Trig]** interface) on the rear panel outputs a pulse. You can press the corresponding key to set the output mode of the corresponding pin.

## 6 Power Key



Press this key to turn on or off the instrument.

## 7 USB Host

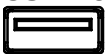

Via this interface, M300 can be connected with an USB storage device as host device to store or recall instrument status, measurement configuration, measurement data and etc.

**Note:** Only the FAT32 format flash memory USB storage device is supported.

### 8 Menu Softkeys

Correspond to the menus above them. Pressing any softkey can enable the corresponding menu.

### 9 View Switch

View the scan history information, channel status table, measurement curve and channel information.



- Scan history information: view the start time, scan sweep, count, channel number as well as the corresponding function, maximum, minimum, average and standard deviation measured as well as the scan readings of each channel of the latest scan.
- Channel status table: display the current status of each channel.
- Measurement curve: display the measurement curve of the specified channel.
- Channel information: view the cycle count of each relay of the module, the alarm messages of the current scan (the first 100 on each alarm channel, including the reading and time when the alarm is generated) and error messages (up to 20).

**Note:** Up to 100 alarm messages on each alarm channel can be logged in the alarm queue and the subsequent alarm messages would be lost. Up to 20 error messages can be logged in the error queue and the other error messages will also be lost.

### 10 Module Indicators



Correspond to the 5 module slots on the rear panel respectively. The corresponding module indicator goes on when the module is inserted into the slot on the rear panel.



## Rear Panel

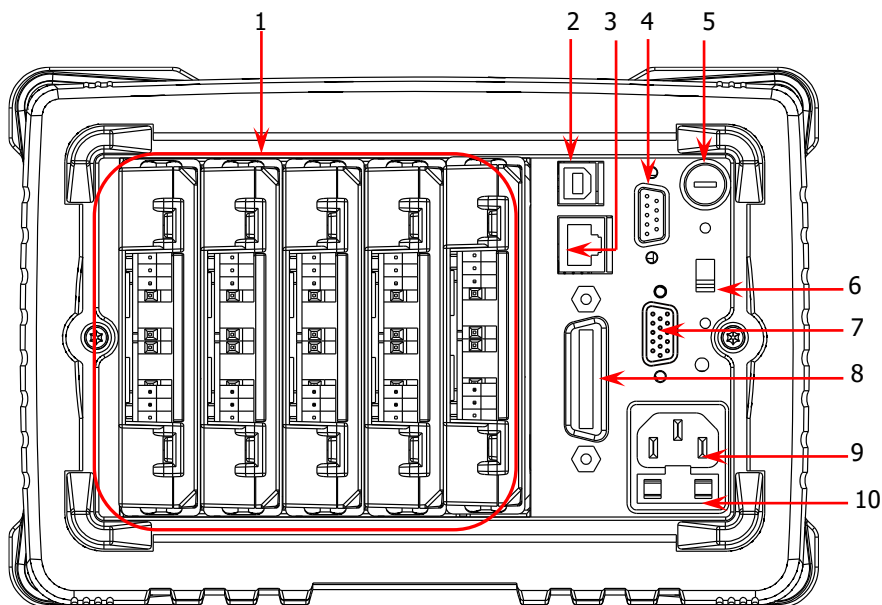

Figure 4 M300 Rear Panel

### 1 Slots

M300 provides 5 slots for 5 modules. The 5 slots from left to right in the figure above correspond to the 5 module indicators on the front panel respectively. When a module is inserted in the slot, the corresponding module indicator on the front panel goes on. Figure 4 is the schematic diagram of the rear panel without any module inserted. For the information of each module, refer to “**Plug-in Module Overview**”.



### CAUTION

Only a single DMM module is permitted for one mainframe.

### 2 USB Device Interface

Via this interface, M300 can communicate with the PC as a slave device and you can control it remotely via the PC.

### 3 LAN

M300 conforms to the LXI Core 2011 Device standard. The instrument can be connected to the network via this interface and you can control the instrument remotely via a PC in the same network.

### 4 Analog Bus Interface (Female)

M300 provides two internal 2-wire analog buses for signal routing as well as an external analog bus interface (namely analog bus interface). The analog bus

interface is a 9-pin female interface.

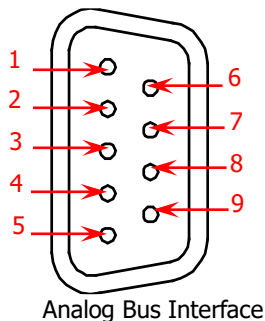

Pin	Definition
1	Current Input
2	Lo
3	LoSense
4	--
5	--
6	Hi
7	HiSense
8	Float GND
9	--

### 5 DMM Module Power Fuse

The AC power supply input from the power socket is divided into two paths with one for the DMM module and the other for the other circuits. M300 is equipped with the DMM module power fuse (AC 250V T250 mA). To replace the fuse, refer to the method below.

- 1) Turn off the instrument and remove the power cord.
- 2) Press down the fuse cover using a straight screw driver and rotate the straight screw driver clockwise.
- 3) Select a proper voltage through the voltage selector.
- 4) Disassemble the fuse cap and fuse.
- 5) Replace a specified fuse and install the fuse cap.



#### CAUTION

Please use the specified fuse to avoid electric shock or fire.

### 6 Voltage Selector

M300 supports two kinds of AC voltages (115 V and 230 V). Please select the proper voltage scale according to the AC power used.

### 7 RS-232/Alarms/Ext Trig Mix Interface (Male)

This is a 15-pin male interface.

Pin	Function		Pin	Function	
1	Alarm1	Output	9	PC_RX	Output
2	Alarm2	Output	10	PC_DSR	Output
3	Alarm3	Output	11	GND	—
4	Alarm4	Output	12	PC_DTR	Input
5	CH Close	Output	13	PC_CTS	Output
6	Trig	Input	14	PC_RTS	Input
7	GND	—	15	NC	—
8	PC_TX	Input	—	—	—

You can convert this interface into two 9-pin interfaces using the Mix Interface Convert Cable (accessory); wherein, one is a 9-pin male interface used as a standard RS232 interface and the other is a 9-pin female interface used for alarm output, external trigger signal input and etc.

- RS232: via this interface, M300 can communicate with the PC and you can control the instrument remotely via the PC.

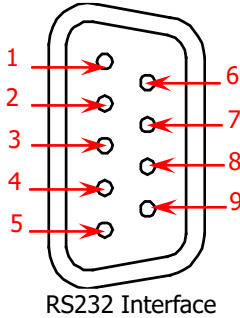

Pin	Name	Definition
1	--	--
2	RXD	Received Data
3	TXD	Transmitted Data
4	DTR	Data Terminal Ready
5	SGND	Signal Ground
6	DSR	Data Set Ready
7	RTS	Request To Send
8	CTS	Clear To Send
9	--	--

- Alarms/Ext Trig: as shown in the figure below, pin 1 to pin 4 are used to output TTL pulse when an alarm is generated in the corresponding alarm channel. Pin 6 is used to receive external trigger signal. When an external digital multimeter is connected for measurement, pin 5 and pin 6 are used together to control the measurement.

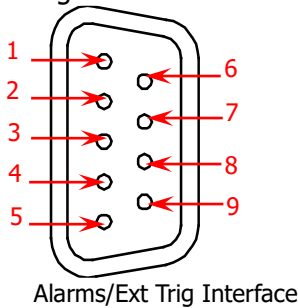

Pin	Definition
1	Alarm 1 Output
2	Alarm 2 Output
3	Alarm 3 Output
4	Alarm 4 Output
5	Channel Closed Output
6	Ext Trig Input/Channel Advance Input
7	GND
8	Not Used
9	Not Used

**Note:**

Pin 5 outputs a TTL negative pulse with about 7μs pulse width at each measurement completion. The output rate is dependent upon the actual measurement rate and cannot exceed 1000 times per second.

In external trigger mode, when Pin 6 accepts an external trigger signal with a pulse width equal to or greater than 2μs and specified edge (press **Config**, select "External" trigger mode and select "Rising" or "Falling" in the **Edge** item), the instrument triggers. If the external trigger signal is a continuous pulse, please make sure the pulse period is greater than 100μs.

## 8 GPIB Interface

M300 conforms to the IEEE-488.2 standard. Via this interface, M300 can communicate with the PC and you can control the instrument remotely via the PC.

## 9 Power Socket

M300 can accept two kinds of AC power supplies. Use the power cord provided in the accessories to connect the AC power supply to the instrument via this socket.



### CAUTION

Before connecting the AC power supply, select the correct voltage scale using the **voltage selector**.

---

## 10 Power Fuse

The specification of the fuse of M300 is AC 250V T3.15 A. If a new fuse is required, please refer to the following steps.

- 1) Turn off the instrument and remove the power cord.
- 2) Insert a small straight screwdriver into the slot at the power socket and prize out the fuse seat.
- 3) Replace a specified fuse.
- 4) Insert the fuse seat into the slot.



### CAUTION

Please use the specified power fuse and make sure that the fuse seat is not short-circuited to avoid electric shock or fire.

---

## Power On and Inspection

### 1 Connect the power

- 1) Adjust the power voltage selector on the rear panel according to the power supply voltage. M300 supports two types of AC power inputs:  
If your supply voltage is between  $115 \times (100\% - 10\%)$  V and  $115 \times (100\% + 10\%)$  V, please select 115.  
If it is between  $230 \times (100\% - 10\%)$  V and  $230 \times (100\% + 10\%)$  V, please select 230.
- 2) Connect the instrument to AC power using the power cord provided in the accessories.

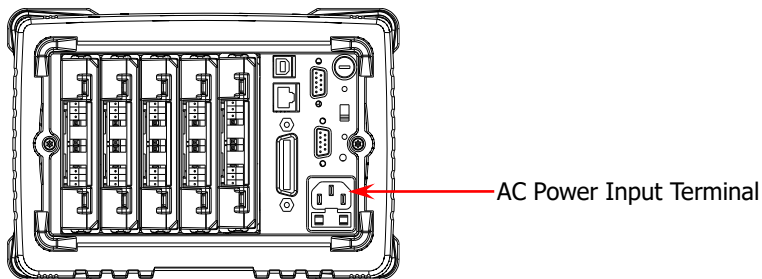

### 2 Start the instrument

Press the power key on the front panel and the instrument starts.

After the instrument starts, it checks the modules. This process would take a few seconds according to the number of modules inserted. During this process, user operation is forbidden.

### 3 Check the instrument following the steps below if the instrument does not start normally





- Check whether the power is correctly connected.
- Check whether the power key on the front panel is really on.
- Remove the power cord and check whether the voltage selector is at the correct scale and whether the power fuse is burned out. If the fuse is burned out, replace it with a specified one.
- Restart the instrument after finishing the above inspections.
- If it still does not work correctly, please contact **RIGOL**.

# User Interface



Figure 5 User Interface

## 1 Status Bar

- Help      Displayed when the built-in help is enabled.
- Error     Displayed when an error occurs.
-       Displayed when the keyboard is locked.
-       Displayed when an alarm is generated.
-       Displayed when the system sound is disabled.
-       Displayed when the instrument is connected to network correctly.
-       Displayed when an USB storage device is detected.
- Local     Displayed when the instrument is in local mode.
- Rmt      Displayed when the instrument is in remote mode.

## 2 Content Bar

Display the measurement configuration guide, measurement parameters settings and etc. For more detailed information, please refer to the User's Guide.

## 3 Menu Bar

Display the menus of the current function. The menus correspond to the menu softkeys below respectively. Pressing the softkey can activate the corresponding menu.

## Plug-in Module Overview

M300 provides 10 kinds of modules including the DMM module, 20-channel multiplexer, 32-channel multiplexer, 64-channel multiplexer, multi-function module and etc. This section introduces the functions and characteristics of each module.

### Outside View Drawing

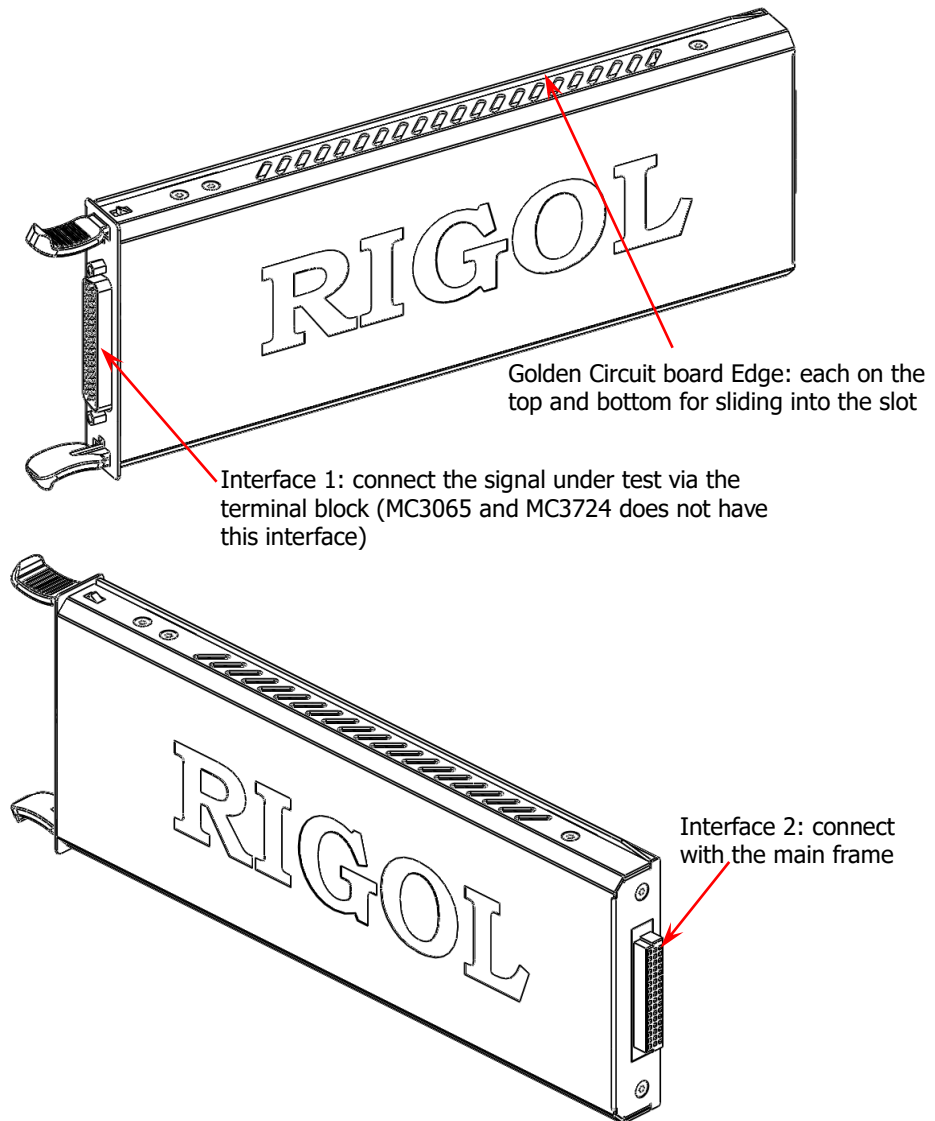

Figure 6 Outside View Drawing of the Plug-in Module

## Insert the Module into the Main Frame

Turn the main frame off; and then, insert the modules following the instructions below.

As shown in Figure 6, there is a golden circuit board edge on the top and bottom of the module. Align the two edges with the sliding chutes (as pointed out by the arrows in the figure below) in the main frame slot and push the module in until you hear a sound. At this point, interface 2 is connected to the main frame.

**Note:** For module that needs to be connected to the signal under measurement, please refer to “**Measurement Connections**” to connect the external terminal block and the signals under measurement before inserting it into the mainframe.

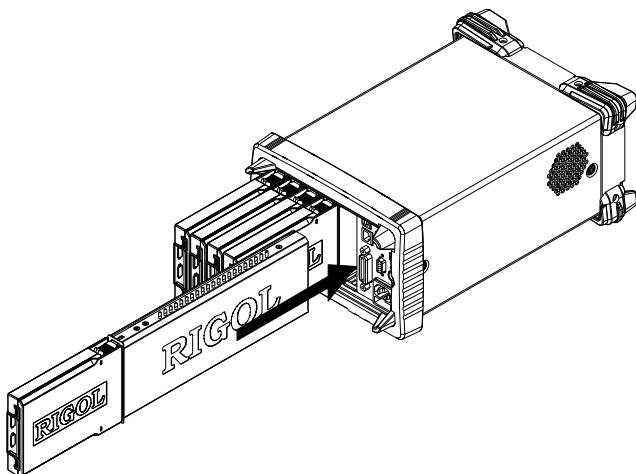

Figure 7 Insert the Module into the Main Frame



### CAUTION

All the modules of M300 do not support hot-plugging. Please turn the main frame off before inserting the modules into the main frame.

---



## Module Overview

### 1 MC3065 (DMM Module):

The DMM module is used to measure the signals under test and provides 6½ digit reading resolution. Its measurement functions include DCV, ACV, DCI, ACI, 2-wire resistance, 4-wire resistance, frequency, period, temperature and any sensor.

**Note:** After connecting the DMM module, make sure that the signal under test connected to the analog bus is no greater than 300 Vdc or 300 Vrms.

### 2 MC3120 and MC3120A (20-Channel Multiplexer):

All the 20 channels switch both HI and LO inputs, thus providing fully isolated signals for the DMM module. This module is divided into two banks (called A and B) with 10 two-wire channels in each bank. When making 4-wire resistance measurement, the instrument automatically pairs channels of A bank and B bank. All channels in the scan list are break-before-make. You can close multiple channels on this module only if you have not configured any channel to be part of the scan list.

This module can be connected with MC3065 (DMM Module, if MC3065 is currently inserted).

For the specifications of this module, please refer to the User's Guide or Data Sheet of this product.

### 3 MC3132 (32-Channel Multiplexer):

All the 32 channels switch both HI and LO inputs, thus providing fully isolated signals for the DMM module. MC3132 is divided into two banks (called A and B) with 16 two-wire channels in each bank. When making 4-wire resistance measurement, the instrument automatically pairs channels of A bank and B bank. All channels in the scan list are break-before-make. You can close multiple channels on this module only if you have not configured any channel to be part of the scan list.

This module can be connected with MC3065 (DMM Module, if MC3065 is currently inserted).

For the specifications of this module, please refer to the User Guide or Data Sheet of this product.

### 4 MC3164 (64-Channel Single-Ended Multiplexer):

All the 64 channels can only switch HI input. MC3164 is divided into two banks (A and B) with 32 single-ended channels in each bank. All channels in the scan list are break-before-make. In any case, you cannot close multiple channels on this module.

This module can be connected with MC3065 (DMM Module, if MC3065 is currently inserted) but cannot be used for 4-wire resistance measurement.

For the specifications of this module, please refer to the User's Guide or Data Sheet of this product.

**5 MC3324 (24-Channel Multiplexer):**

All the 20 voltage channels switch both HI and LO inputs, thus providing fully isolated inputs for the DMM module. The 20 voltage channels are divided into two banks (called A and B) with 10 two-wire channels in each bank. When making 4-wire resistance measurement, the instrument automatically pairs channels of A bank and B bank. All channels in the scan list are break-before-make<sup>[1]</sup>. You can close multiple channels on this module only if you have not configured any channel to be part of the scan list.

The 4 current channels are used in combination with the DMM module to perform DC current or AC current measurement. All channels in the scan list are break-before-make<sup>[1]</sup>. In any case, you cannot close multiple channels on this module.

This module can be connected with MC3065 (DMM Module, if MC3065 is currently inserted).

For the specifications of this module, please refer to the User's Guide or Data Sheet of this product.

**Note** <sup>[1]</sup>: *break-before-make* means that only one channel can be closed at each time. For voltage channels (channel 1 to channel 20), it is always to open the connection between the channel and the DMM module before closing the connection between the next channel and the DMM module during a scan. For current channels (channel 21 to channel 24), the following operations are performed during a scan: to close the short relay of the channel, to open the connection between the channel and the DMM module, to close the connection between the next channel and the DMM module and to open the short relay of the next channel.

**6 MC3416 (16-Channel Actuator):**

MC3416 can connect signal to the device under test or enable external device. Any of the 16 channels can switch to Normally-Open (NO) and Normally-Closed (NC) states.

For the specifications of this module, please refer to the User's Guide or Data Sheet of this product.

**7 MC3534 (Multifunction Module):**

It provides 3 kinds of functions with 4 channels for each function. This module can be used to check status or control external device (such as the solenoid, power relay and microwave switch). You can also read the digital inputs and the totalizer count during a scan.

- Four 8-bit digital input/output (DIO) ports
- 4 totalizer (TOT) input terminals (the first two channels are 10 MHz TOT and the other two channels are 100 kHz TOT) with 1 V<sub>pp</sub> sensitivity
- 4 analog output terminals, ±12 V calibrated voltage

For the specifications of this module, please refer to the User's Guide or Data Sheet of this product.

**8 MC3648 (4×8 Matrix Switch):**

MC3648 is used to connect multiple devices to multiple points on the device

under test. You can connect the rows and columns of multiple matrix switches to form relatively larger matrix (such as 8×8 and 4×16, the number of crosspoints cannot exceed 160).

32 two-wire crosspoints which can connect any combination of inputs and outputs at the same time. For the specifications of this module, please refer to the User's Guide or Data Sheet of this product.

## 9 MC3724 (Dual 4-Channel RF Multiplexer)

MC3724 provides two independent banks of 4-channel RF multiplexers and can be used to switch high frequency pulse signals.

- The channels in each bank have a common earth ground (the outer layer of the SMB connectors is grounded).
- Only one channel in each bank may be closed at a time.
- You can connect your signals directly to the on-board SMB connectors (2 GHz bandwidth) or to the SMB-to-BNC cables (1 GHz bandwidth) provided with the module.
- You can cascade multiple RF multiplexers to create larger RF multiplexer.

## To Use the Built-in Help System

The built-in help system of M300 provides the help information about any front panel key and menu. To acquire the help information of any front panel key or menu, press **Help** (the backlight goes on and "Help" is displayed in the status bar in the user interface) and then press the desired key or menu. The built-in help interface is as shown in the figure below. Pressing **OK** can exit the built-in help system.

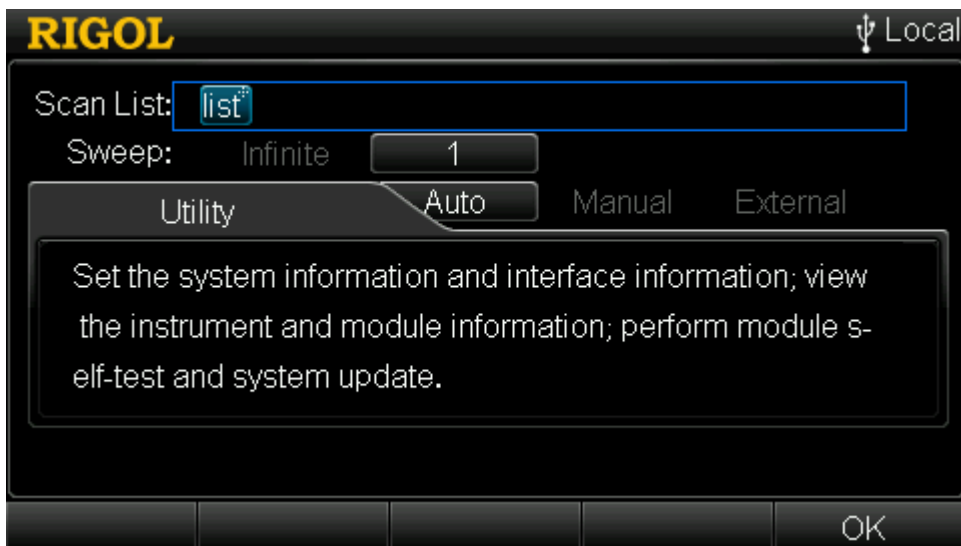
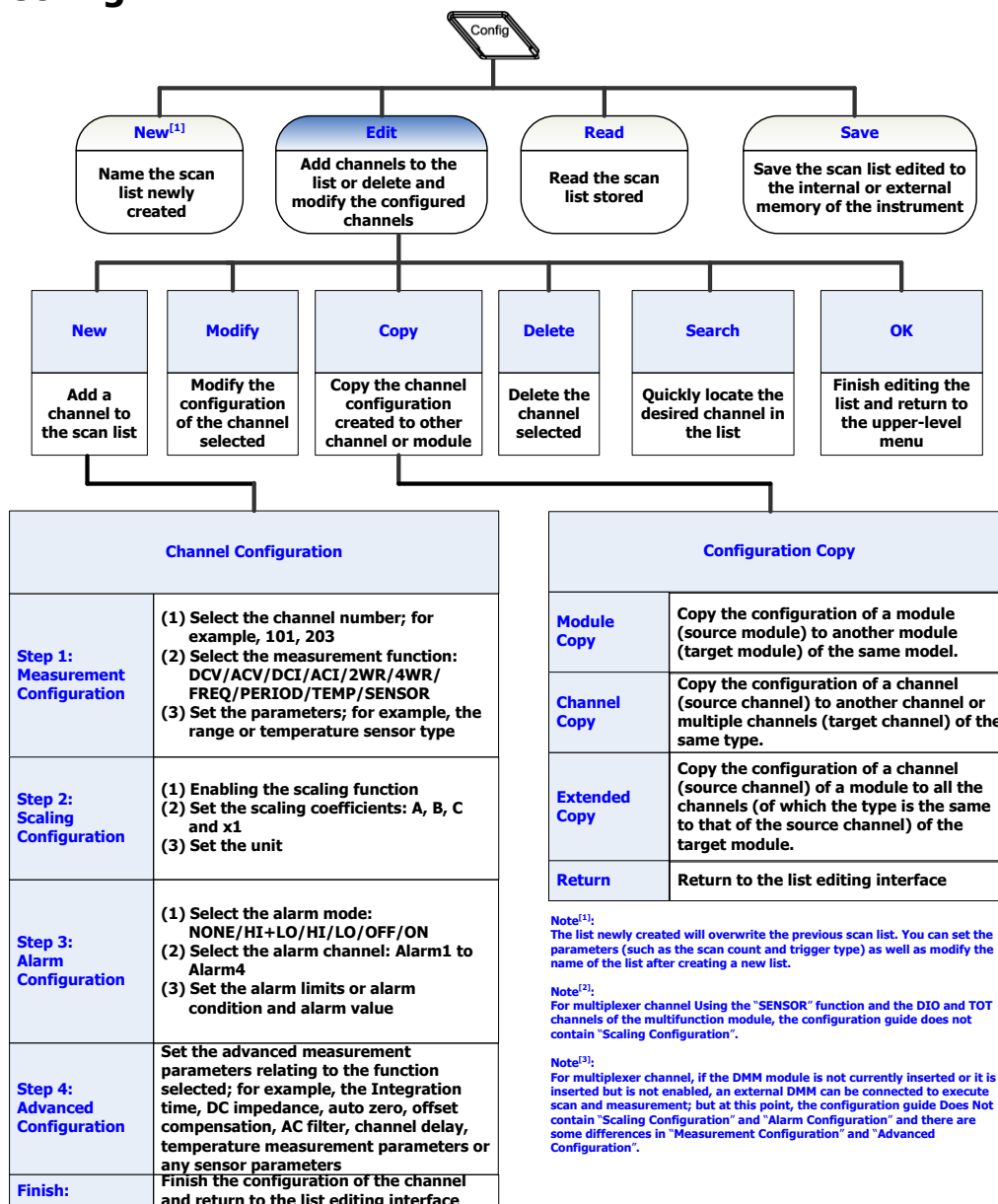

Figure 8 Built-in Help System

# Menu Quick Navigation

This section provides the structure diagrams of the main menus for M300 to guide users to quickly get familiar with the operation methods of M300. For more detailed information, please refer to the User's Guide.

## Config



# Monitor

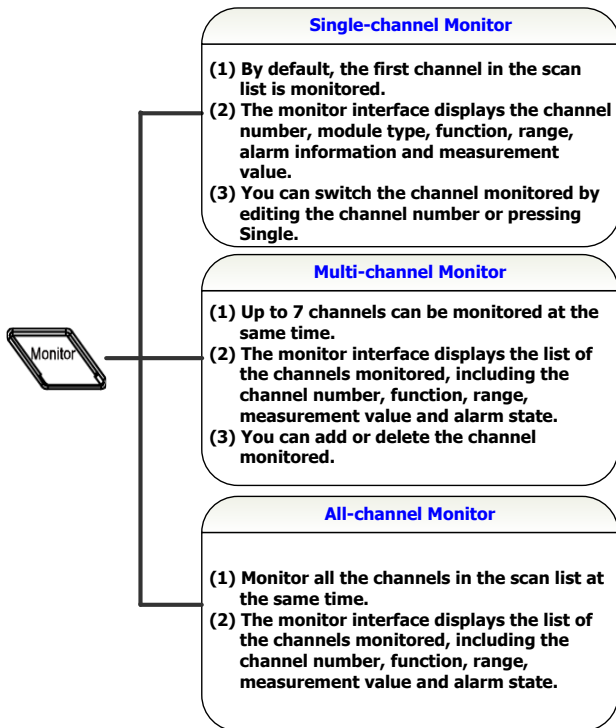

# View Switch Key

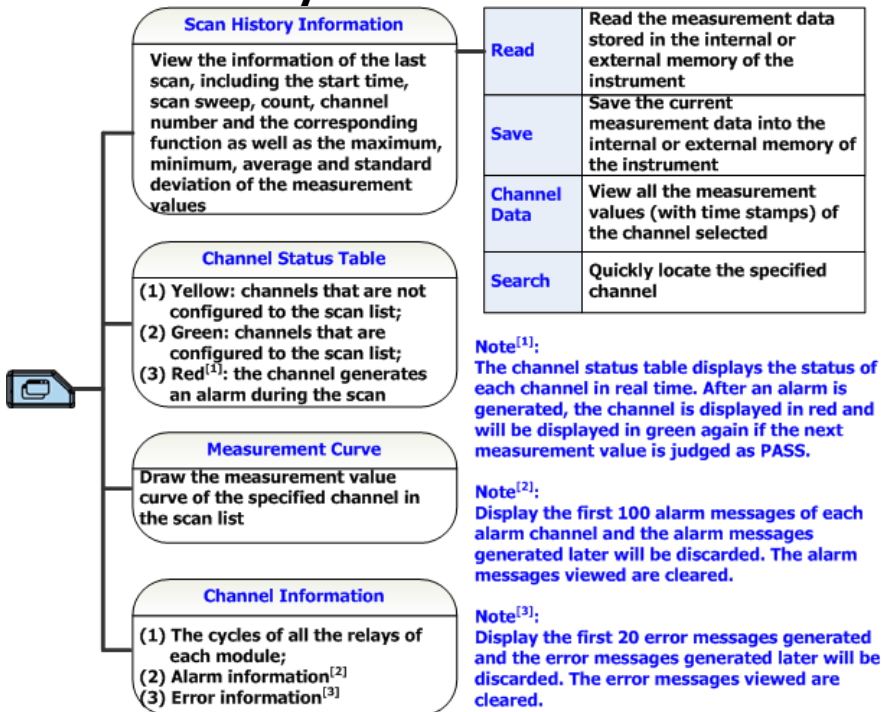

# Control

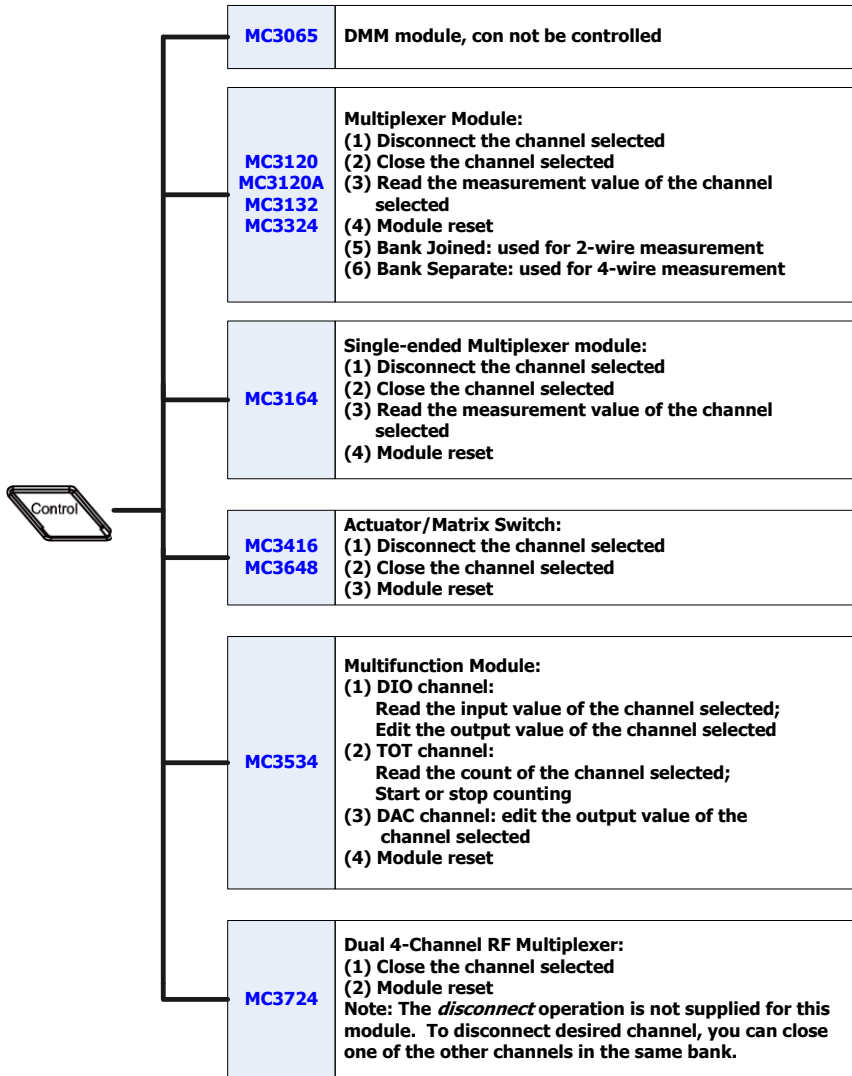

## Alarm Channel Setting Keys

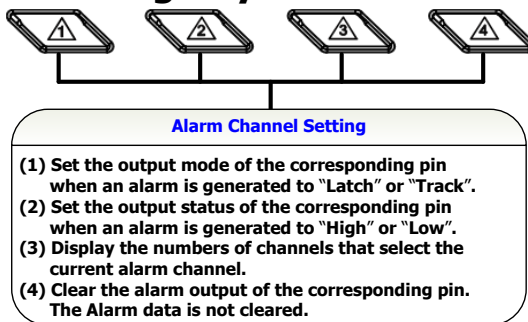

## Basic Operations

This section introduces the basic operations of M300, including how to connect the signals to be measured, how to configure the scan list as well as how to control the instrument remotely.

## Measurement Connections

Multiple signals to be measured are connected to the plug-in modules through the external terminal blocks and then are switched to the DMM module or external DMM. M300 provides 9 kinds of terminal blocks. The models of the terminal blocks and their corresponding modules are listed in the table below. This section introduces how to connect the signals to be measured through the external blocks.

**Note:** For MC3724, there is no terminal block. You can connect your signals directly to the on-board SMB connectors or to the SMB-to-BNC cables provided with the module.

Table 1 External Terminal Blocks

	<b>Terminal Block</b>	<b>Module</b>
1	M3TB20	MC3120
2	M3TB20A	MC3120A
3	M3TB32	MC3132
4	M3TB32T	MC3132
5	M3TB64	MC3164
6	M3TB24	MC3324
7	M3TB48	MC3648
8	M3TB16	MC3416
9	M3TB34	MC3534



### **WARNING**

Cut off all the power supplies before opening the terminal block or removing the terminal block from the module.

- 1 Place the terminal block with the front (with the **RIGOL** caption) facing downward and pull the two latches in the arrow direction in the figure below and press them down. Place the terminal block with the front facing upward and pull the upper cover of the terminal block upward and remove it.

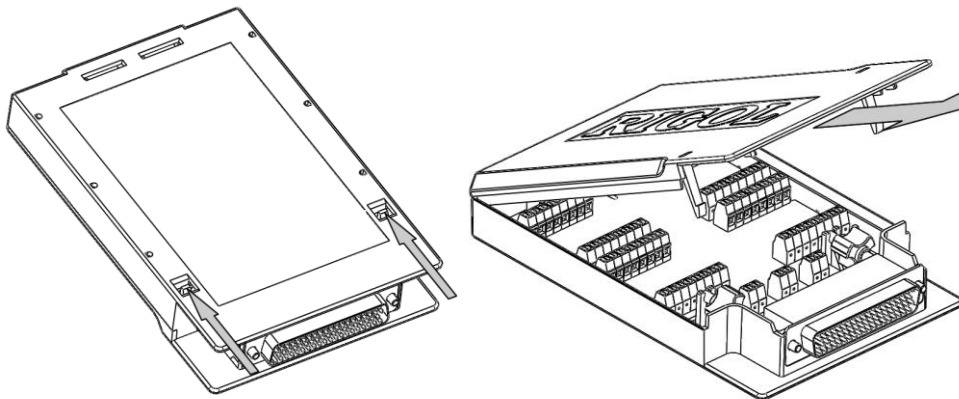

- 2 Connect the cables for connecting the signal under test according to the labels on the circuit board of the terminal block (for the connecting method, refer to Table 2). Pass the binding wires through the two groups of holes as pointed out by the arrows in the figure below to fix the cable connected. Pay attention to the channel or terminal connected to the cable to ensure that the signal connected is correct.

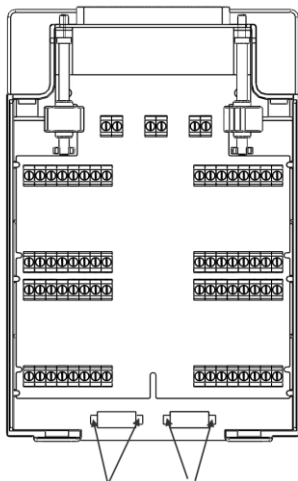

**Note:**

- For the connection method of each module and the corresponding terminal block as well as the specification requirements of the connecting cable, please log in **RIGOL** official website ([www.rigol.com](http://www.rigol.com)) get more related



materials.

- When using the multiplexer module for measurement, make sure that both the amplitude of the signal under measurement and the common mode voltage are no greater than the maximum input voltage of the module.
- When the multiplexer module is used to measure an object with high-power output ability (such as battery and power supply), to avoid damaging the relay, you are recommended to connect a fuse in serial when making connections (as shown in the figure below).

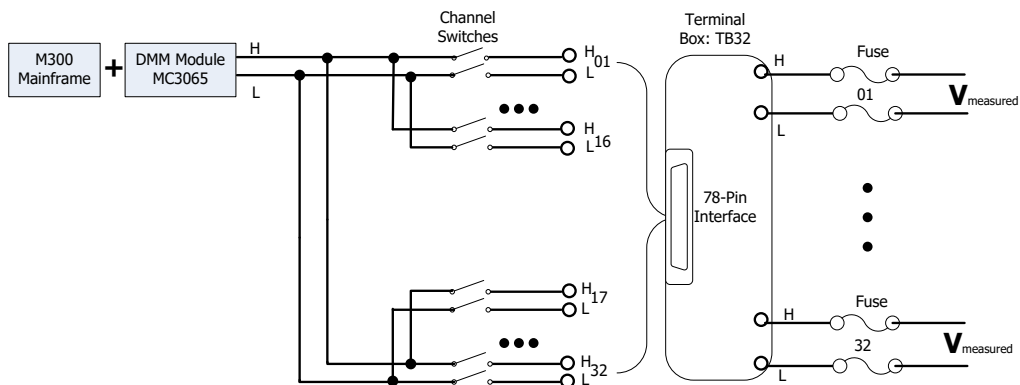
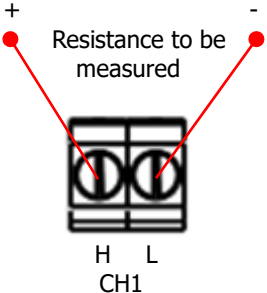
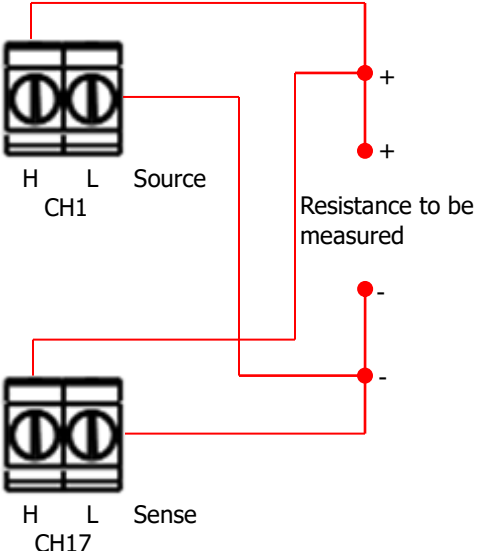
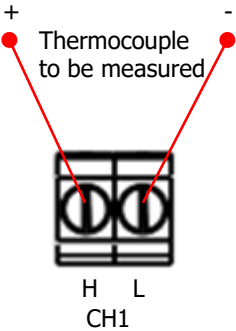

Table 2 Measurement Connections

DCV/ACV/FREQ/PERIOD/Sensor (DCV, FREQ)	DCI/ACI/Sensor (DCI)
<p style="text-align: center;">H L CH1</p>	<p style="text-align: center;">H L CH21</p> <p>Note: Only available for CH21 to CH24 of MC3324.</p>

Table 2 Measurement Connections (Continued)

<p><b>2WR/RTD/Thermistor/ Sensor (2WR)</b></p>  <p>Resistance to be measured</p> <p>H L CH1</p>	<p><b>4WR/RTD 4W/Sensor (4WR)</b></p>  <p>H L Source CH1</p> <p>H L Sense CH17</p> <p>Note: Available for CH1 to CH32 of MC3132.</p>
<p><b>Thermocouple</b></p>  <p>Thermocouple to be measured</p> <p>H L CH1</p>	



**WARNING**

To avoid electric shock, the measurement cables should meet the maximum voltage requirement. To avoid damaging the module, make sure that all the input signals are within the rated input range.

- 3 Connect the terminal block to interface 1 (the interface definition is in Figure 6) on the module, screw down the two screw rods to fix them onto the nuts on the module.

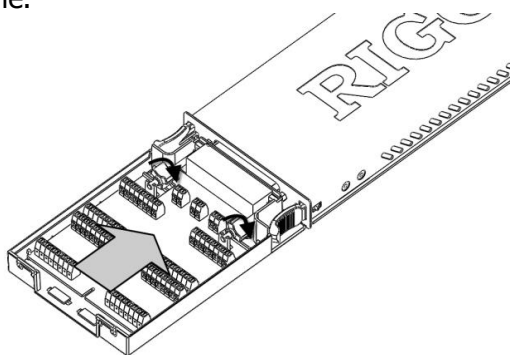

- 4 Close the upper cover of the terminal block.

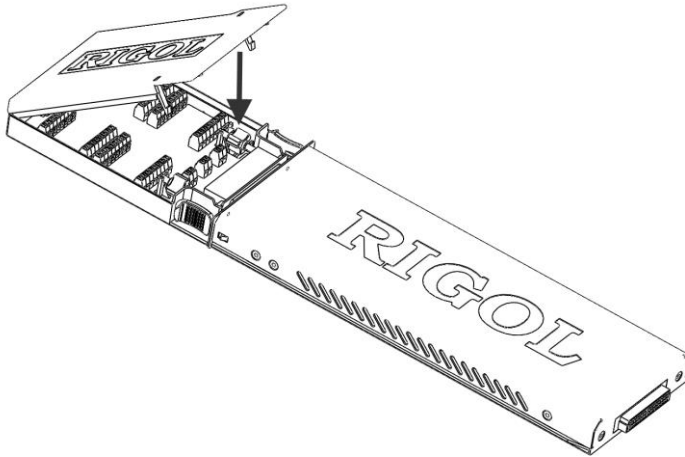

- 5 Insert the module connected with the terminal block into the slot of the main frame.

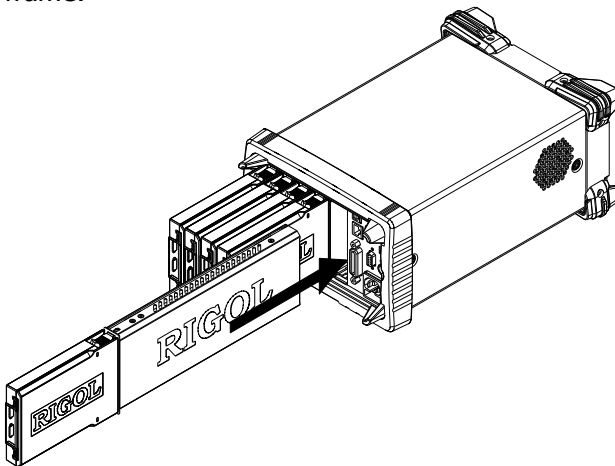

## To Configure Scan List

Create a scan list and add any channels of the multiplexer or the DIO or TOT channels of the multifunction module to the scan list; then, configure the basic measurement, scaling, alarm and advanced measurement parameters for each channel. The edited scan list can be stored in internal or external memory and be recalled when required.

### 1 Create a new list

Press **Config** → **New**, input the desired list name and press **OK**.

**Note:** The existing scan list will be overwritten by the scan list currently created.

### 2 Set the scan parameters

- (1) Select **Sweep** and use the left/right arrow key to select "Infinite" or "1" (you need to set a value and the range is from 1 to 50000).
- (2) Select **Trigger Mode** and use the left/right arrow key to select "Auto", "Manual", "External", "AbsTime" or "Alarm".
- (3) If "Auto" is selected, please select **Interval** and use the numeric keyboard to set a desired interval. The range is from 00:00:00.000 to 99:59:59.999 (the time format is Hour:Minute:Second.Millisecond) and the default is 0. If "External" is selected, please select **Edge** and use the left/right arrow key to select "Rising" or "Falling". If "AbsTime" is selected, please select **AbsTime** and use the numeric keyboard to set a desired time. The time format is "Month-Date Hour:Minute:Second". If "Alarm" is selected, please select **Channel** and use the left/right arrow key to select "Alarm1", "Alarm2", "Alarm3" or "Alarm4".

### 3 Configure a channel to the scan list (taking the DCV measurement function as an example)

Press **Config** → **Edit** → **New** to enter the channel configuration guide.

- (1) Step 1: Measurement Configuration  
Select **Chan No.** and use the left/right arrow key to select the desired channel number (for example, 101);  
Select **Function** and use the left/right arrow key to select the desired function (for example, DCV);  
Select **Range** and use the left/right arrow key to select the desired range (for example, 2V).

**Note:** The parameters need to be set in this step depend on the measurement function selected.

- (2) Step 2: Scaling Configuration  
Select **Scaling** and use the left/right arrow key to enable the scaling

configuration;

Select **A**, **B** and **C** and use the numeric keyboard to input the desired scaling coefficients;

Select **x1** and press **Curr Value** to acquire x1.

Select **Unit** and input the desired unit.

**Note:** For multiplexer channel using the "SENSOR" function and the DIO and TOT channels of the multifunction module, the configuration guide does not contain scaling configuration. Besides, for multiplexer channel, if the DMM module is not currently inserted or it is inserted but is not enabled, the configuration guide also does not contain "Scaling Configuration" when an external DMM is connected to execute scan and measurement.

(3) Step 3: Alarm Configuration

Select **Mode** and use the left/right arrow key to select the desired alarm mode (for example, HI);

Select **Channel** and use the left/right arrow key to select the desired alarm channel (for example, Alarm1);

Select **HI** or **LO** and use the numeric keyboard to input the desired alarm limit (for example, 12).

**Note:** For multiplexer channel, if the DMM module is not currently inserted or it is inserted but is not enabled, the configuration guide does not contain "Alarm Configuration" when an external DMM is connected to execute scan and measurement.

(4) Step 4: Advanced Configuration

Select **Integ** and use the left/right arrow key to select the desired integration time (for example 1PLC);

Select **IMP** and use the left/right arrow key to select 10MΩ or >10GΩ;

Select **AZ** and use the left/right arrow key to select "ON" or "OFF";

Select **Delay** and use the left/right arrow key to "Auto" or set the delay time manually.

**Note:** The parameters need to be set in this step depend on the measurement function selected.

Press **Done** to finish the channel configuration guide and return to the scan list editing interface.

#### 4 Configure other channels to the scan list

Press **New** and configure other channels to the scan list according to step 3.

#### 5 Save the scan list

After the scan list configuration is completed, you can press **Save** to save the configured scan list in the internal or external memory of the instrument.

# Configuration Copy

M300 provides the configuration copy function (include module copy, channel copy and extended copy) which can be used to quickly configure multi-channels with the same configuration to the scan list.

Press **Config** → **Edit** → **Copy** to enter the configuration copy interface.

## 1 Module Copy:

Copy the configuration of a module (source module) to another module (target module) of the same model. After that, the configuration of each channel of the source module is copied to the target module automatically.

Press **Module** in the configuration copy interface to open the module copy interface.

- (1) The "Source Module" area is selected by default. Use the up/down arrow key to select the desired source module.
- (2) Press **Switch** to move the cursor to the "Target Module" area and use the up/down arrow key to select the desired target module.
- (3) Press **OK** to execute module copy.

**Note:** The source module and target module selected must be of the same model. The configuration of a module to itself is not supported.

## 2 Channel Copy:

Copy the configuration of a channel (source channel) to another channel or multiple channels (target channel) of the same type.

Press **Channel** in the configuration copy interface to open the channel copy interface. By default, the channel selected is fixed as the source channel and the upper area is selected. At this point, use the left/right arrow key to select the desired target channel and press **OK** (pressing **OK** again will give up the selection); press **Done** to execute channel copy.

After opening the channel copy interface, you also can press **Switch** to fix the channel selected as the target channel. At this point, the lower area is selected. Use the left/right arrow key to select the desired source channel and press **Done** to execute channel copy.

### Tips:

- (1) When the channel selected is fixed as the source channel, multiple target channels can be selected and will be displayed in the lower area.
- (2) When the channel selected is fixed as the target channel, only a single source channel can be selected.
- (3) **Switch** is grayed out and disabled if the current scan list only has a single

channel.

**Note:** For channel copy, only copies between channels of the same type (namely, channels of the same type of modules) are allowed.

### 3 Extended Copy:

Copy the configuration of a channel (source channel) of a module to all the channels (of which the type is the same to that of the source channel) of the target module.

Press **Extended** in the configuration copy interface to open the extended copy interface.

- (1) The "Source Channel" area is selected by default. Use the arrow keys to select the desired source channel.
- (2) Press **Switch** to move the cursor to the "Target Module" area and use the up/down arrow key to select the desired target module.
- (3) Press **OK** to execute extended copy.

**Note:** For extended copy, only copies among the same type of modules are allowed. This function makes it easy to configure several channels with the same configurations.

## Channel Monitor

The channel monitor function of M300 allows users to monitor a single channel, multiple channels or all of the channels in the scan list. The instrument monitors the channel and takes readings from the channel monitored continuously even during a scan. This function is helpful for troubleshooting your system before a test or for observing important signals.

The channel monitor function can monitor the following channels: multiplexer channels (configured to the scan list and the DMM module is enabled), DIO and TOT channels of the multifunction module (no matter whether they are configured to the scan list and the DMM module is not required). Press **Monitor** on the front panel to configure the channel monitor function.

### 1 Single-channel Monitor

Press **Monitor** → **Single** to enter the single-channel monitor interface. By default, the first channel in the scan list is monitored. If no scan list is currently configured, the first channel of the multifunction module (DIO channel) is monitored. Only a single channel can be monitored at a time; but you can change the channel being monitored at any time. Readings acquired during the monitor process are displayed on the screen but will not be stored in memory. When the alarm function is applied to the channel being monitored, all the alarm

data will be stored in the alarm queue (the data will be cleared at power-off). To monitor a multiplexer channel, the DMM module must be installed and enabled (**Utility** → **DMM** → "ON"); the channel to be monitored must be configured to the scan list. You can monitor a DIO or TOT channel even if the channel is not configured to the scan list.

## 2 Multi-channel Monitor

Press **Monitor** → **Multiple** to enter the multi-channel monitor interface. At most 7 channels can be monitored. You can add or delete the channels being monitored.

## 3 All Channel Monitor

Press **Monitor** → **All Moni** to enter the all channel monitor interface. All the channels in the scan list can be monitored.

# Remote Control

M300 can communicate with PC through USB, LAN, GPIB and RS232 (converted from the **[RS-232/Alarms/Ext Trig]** interface on the rear panel of M300) to realize remote control based on the SCPI (Standard Commands for Programmable Instruments) commands. This section introduces how to use the PC software **Ultra Sigma** of **RIGOL** to control the instrument remotely through the USB interface. For the detailed information about the SCPI commands, please refer to the Programming Guide.

## 1 Install Ultra Sigma

Download Ultra Sigma from **RIGOL** website ([www.rigol.com](http://www.rigol.com)) and install it according to the instructions.

## 2 Control the instrument via USB

### (1) Connect the devices

Connect the USB Device interface of M300 to the USB Host interface of your computer using a USB cable.

### (2) Install the USB driver

As this instrument is a USB-TMC device, after you connect it to the PC and turn both on for the first time, Found New Hardware Wizard is displayed on the PC. Please install the "USB Test and Measurement Device (IVI)" driver following the directions in the wizard.

### (3) Search for device resources

Start up **Ultra Sigma** and the software will automatically search for the instrument resources currently connected to the PC. You can also click

**USB-TMC** to search for the resources.

### (4) View the device resource

The resources found will appear under the "RIGOL Online Resource"





directory and the model number and USB interface information of the instrument will also be displayed as shown in the figure below.



Figure 9 View USB Instrument Resource

#### (5) Send Command/Read Data

Right click the resource name "M300 (USB0::0x1AB1::0x0C80::M300123123123::INSTR)" and select "SCPI Panel Control" to turn on the remote command control panel through which you can send commands and read data.

**Note:** When the instrument is in remote mode, **Rmt** is displayed in the status bar in the user interface and all the keys on the front panel (except ) are locked. At this point, you can press  to exit the remote mode.

# Troubleshooting

When the failures listed below occur, please solve them according to the following steps. If the problem persists, please contact **RIGOL** and provide the system information of your instrument (**Utility** → **Info**).

## 1 The instrument does not start.

- 1) Check whether the power cord is correctly connected.
- 2) Check whether the power switch on the front panel is really on.
- 3) Remove the power cord; check whether the voltage selector is at the proper scale and whether the power input fuse is burned out. If the fuse is burned out, replace it with a specified one.
- 4) Restart the instrument after executing the above inspections.
- 5) If the problem persists, please contact **RIGOL**.

## 2 The USB storage device cannot be recognized.

- 1) Check whether the USB storage device can work normally.
- 2) Make sure the USB storage device used is FAT32 format and Flash type.
- 3) Restart the instrument and insert the USB storage device to check it.
- 4) If the USB storage device still cannot work normally, please contact **RIGOL**.



## 3 How do I recover the configurations from the last power failure or unexpected shutdown and continue the work before the shutdown automatically?

Restart the instrument. Press **Utility** → **System**, select **Power-off** using the up/down arrow key and select "ON" using the left/right arrow key.

## 4 The screen is too dark.

Press **Utility** → **System**, select **Brightness** using the up/down arrow key and set a proper brightness using the left/right arrow key.

## 5 The instrument is locked.

- 1) Check whether the instrument is in remote mode (namely check whether "Rmt" is displayed in the status bar in the user interface). If yes, you can press  to exit the remote mode and unlock the front panel.
- 2) Check whether the front panel of the instrument is locked (namely check whether  is displayed in the status bar in the user interface). If yes, you can press and hold  to unlock the front panel.
- 3) Check whether a progress bar is displayed in the interface. If yes, please wait and try again until the progress bar disappears.
- 4) If the problem persists, please restart the instrument.

## 6 How do I change the system language?

Press **Utility** → **System**, select **Language** using the up/down arrow key and

select the desired language using the left/right arrow key.

## **7 How do I view the information and model number of the plug-in modules?**

Press **Utility** → **Test**; select the desired module using the left/right arrow key and press **View** to view the information and model number of the module currently selected.

## **8 The corresponding indicator on the front panel does not go on when the module has been inserted.**

- 1) Press **Utility** → **Test**; select the desired module using the left/right arrow key and press **Re-test**.
- 2) If the problem persists, press **View**. If the information of the module cannot be viewed, please refer to the failure 9.
- 3) If the information of the module can be viewed, the module indicator is possibly damaged. Please contact **RIGOL** for maintenance information.

## **9 I cannot view the information of the module or use the module when the module has been inserted.**

- 1) Turn the main frame off and remove the module from the main frame; insert the module into the mainframe again firmly.
- 2) Restart the main frame, wait for about 1 minute and try to view the module information again.
- 3) If the problem persists, please contact **RIGOL**.

## **10 I cannot make configurations or operations related to the DMM module when it has been inserted.**

- 1) Make sure that **Utility** → **System** → **DMM** is set "ON".
- 2) Press **Utility** → **Test**; select the DMM module using the left/right arrow key and press **View** to view whether the information of the DMM module is normal. If the information is not displayed or is not displayed correctly, it is possibly that the DMM module is working abnormally due to high current or power load failure. At this point, please turn the main frame off and restart it a few minutes later.
- 3) If the problem persists, please contact **RIGOL**.

## **11 The GPIB interface cannot work normally.**

- 1) Check whether the cable works normally and the connection is correct and reliable.
- 2) Make sure that the GPIB addresses of M300 and the PC are identical.
- 3) If the problem persists, please contact **RIGOL**.

## **12 The USB Device interface cannot work normally.**

- 1) Check whether the cable works normally and the connection is correct and

reliable.

- 2) Check whether the “USB Test and Measurement Device (IVI)” drive program has been correctly installed on your PC.
- 3) If the problem persists, please contact **RIGOL**.

**13 The RS232 interface cannot work normally.**

- 1) Make sure that the RS232 interface parameters (such as the baud rate) settings of M300 and the PC are identical.
- 2) Check whether the RS232 cable is a cross cable.
- 3) If the problem persists, please contact **RIGOL**.

**14 The LAN interface cannot work normally.**

- 1) Check whether the cable works normally and the connection is correct and reliable.
- 2) Check the IP configuration mode:
  - If DHCP is enabled, please make sure that the current network supports DHCP configuration mode and can distribute network parameters (such as the IP address) to M300 automatically.
  - If DHCP is disabled and Auto IP is enabled, please check whether the IP addresses automatically acquired by M300 and the network parameters of the PC are in the same network segment.
  - If only Manual IP is enabled, please make sure that the network parameter settings of M300 and the PC are in the same network segment.
- 3) If the problem persists, please contact **RIGOL**.