

RIGOL

Service Guide

DS1000Z-E Series Digital Oscilloscope

Aug. 2019
RIGOL (SUZHOU) TECHNOLOGIES INC.

Guaranty and Declaration

Copyright

© 2019 **RIGOL** (SUZHOU) TECHNOLOGIES INC. All Rights Reserved.

Trademark Information

RIGOL is a registered trademark of **RIGOL** (SUZHOU) TECHNOLOGIES INC.

Publication Number

SGA27100-1110

Notices

- **RIGOL** products are covered by P.R.C. and foreign patents, issued and pending.
- **RIGOL** reserves the right to modify or change parts of or all the specifications and pricing policies at the company's sole decision.
- Information in this publication replaces all previously released materials.
- Information in this publication is subject to change without notice.
- **RIGOL** shall not be liable for either incidental or consequential losses in connection with the furnishing, use, or performance of this manual, as well as any information contained.
- Any part of this document is forbidden to be copied, photocopied, or rearranged without prior written approval of **RIGOL**.

Product Certification

RIGOL guarantees that this product conforms to the national and industrial standards in China as well as the ISO9001:2015 standard and the ISO14001:2015 standard. Other international standard conformance certifications are in progress.

Contact Us

If you have any problem or requirement when using our products or this manual, please contact **RIGOL**.

E-mail: service@rigol.com

Website: www.rigol.com

Safety Requirement

General Safety Summary

Please review the following safety precautions carefully before putting the instrument into operation so as to avoid any personal injury or damage to the instrument and any product connected to it. To prevent potential hazards, please follow the instructions specified in this manual to use the instrument properly.

Use Proper Power Cord.

Only the exclusive power cord designed for the instrument and authorized for use within the local country could be used.

Ground the Instrument.

The instrument is grounded through the Protective Earth lead of the power cord. To avoid electric shock, connect the earth terminal of the power cord to the Protective Earth terminal before connecting any input or output terminals.

Connect the Probe Correctly.

If a probe is used, the probe ground lead must be connected to earth ground. Do not connect the ground lead to high voltage. Improper way of connection could result in dangerous voltages being present on the connectors, controls or other surfaces of the oscilloscope and probes, which will cause potential hazards for operators.

Observe All Terminal Ratings.

To avoid fire or shock hazard, observe all ratings and markers on the instrument and check your manual for more information about ratings before connecting the instrument.

Use Proper Overvoltage Protection.

Ensure that no overvoltage (such as that caused by a bolt of lightning) can reach the product. Otherwise, the operator might be exposed to the danger of an electric shock.

Do Not Operate Without Covers.

Do not operate the instrument with covers or panels removed.

Do Not Insert Objects Into the Air Outlet.

Do not insert objects into the air outlet, as doing so may cause damage to the instrument.

Use Proper Fuse.

Please use the specified fuses.

Avoid Circuit or Wire Exposure.

Do not touch exposed junctions and components when the unit is powered on.

Do Not Operate With Suspected Failures.

If you suspect that any damage may occur to the instrument, have it inspected by **RIGOL** authorized personnel before further operations. Any maintenance, adjustment or replacement especially to circuits or accessories must be performed by **RIGOL** authorized personnel.

Provide Adequate Ventilation.

Inadequate ventilation may cause an increase of temperature in the instrument, which would cause damage to the instrument. So please keep the instrument well ventilated and inspect the air outlet and the fan regularly.

Do Not Operate in Wet Conditions.

To avoid short circuit inside the instrument or electric shock, never operate the instrument in a humid environment.

Do Not Operate in an Explosive Atmosphere.

To avoid personal injuries or damage to the instrument, never operate the instrument in an explosive atmosphere.

Keep Instrument Surfaces Clean and Dry.

To avoid dust or moisture from affecting the performance of the instrument, keep the surfaces of the instrument clean and dry.

Prevent Electrostatic Impact.

Operate the instrument in an electrostatic discharge protective environment to avoid damage induced by static discharges. Always ground both the internal and external conductors of cables to release static before making connections.

Use the Battery Properly.

Do not expose the battery (if available) to high temperature or fire. Keep it out of the reach of children. Improper change of a battery (lithium battery) may cause an explosion. Use the **RIGOL** specified battery only.

Handle with Caution.

Please handle with care during transportation to avoid damage to keys, knobs, interfaces, and other parts on the panels.

Safety Notices and Symbols

Safety Notices in this Manual:



WARNING

Indicates a potentially hazardous situation or practice which, if not avoided, will result in serious injury or death.



CAUTION

Indicates a potentially hazardous situation or practice which, if not avoided, could result in damage to the product or loss of important data.

Safety Terms on the Product:

DANGER It calls attention to an operation, if not correctly performed, could result in injury or hazard immediately.

WARNING It calls attention to an operation, if not correctly performed, could result in potential injury or hazard.

CAUTION It calls attention to an operation, if not correctly performed, could result in damage to the product or other devices connected to the product.

Safety Symbols on the Product:



Hazardous Voltage



Safety Warning



Protective Earth Terminal



Chassis Ground



Test Ground

Document Overview

Format Conventions in this Manual:

1. Key

The function keys at the front panel are denoted by the format of "Button Name (Bold) + Text Box". For example, **Utility** denotes the "Utility" key.

2. Menu

The menu items are denoted by the format of "Menu Word (Bold) + Character Shading". For example, **System** denotes the "System" menu item under **Utility**.

3. Operation Step

The next step of operation is denoted by an arrow "→". For example, **Utility** → **System** denotes pressing **Utility** on the front panel and then pressing **System**.

User Manuals of this Product:

The user manuals of this product include the Quick Guide, User Guide, Programming Guide, Data sheet and etc. For the latest version of the desired manual, download it from www.rigol.com.

Contents

Guaranty and Declaration	I
Safety Requirement	II
General Safety Summary.....	II
Safety Notices and Symbols	IV
Document Overview	V
Chapter 1 Disassembly and Assembly	1-1
Notices to Disassembly and Assembly	1-1
Exploded View Drawing	1-2
Disassemble the Rear Panel	1-4
Disassemble the Metal Rear Panel.....	1-5
Disassemble the Knob	1-6
Disassemble the Front Panel	1-7
Disassemble the Keypad Board and LCD.....	1-8
Disassemble the Main Board.....	1-10
Assembly Procedures.....	1-11
Chapter 2 Troubleshooting&Maintenance	2-1
Troubleshooting	2-1
Maintenance.....	2-3
System Maintenance	2-3
Warranty	2-3
Care and Cleaning	2-4
Environmental Considerations	2-4

Chapter 1 Disassembly and Assembly

Notices to Disassembly and Assembly

Notices:

- Do not disassemble the instrument unless for working requirement.
- Only authorized personnel are allowed to disassemble the instrument.
- Cut off the power supply before disassembling the instrument.
- Please wear anti-static wrist strap or make other anti-static precaution when disassembling the instrument.
- Please use proper tools and follow the correct steps.
- Take care not to deform the metal structure or get hurt when disassembling the metal structures.
- To avoid causing damage to the instrument due to improper operation and to save your time, we recommend you to follow the disassembly steps and methods in this guide manual.

Tools Required:

- Phillips screwdriver T10
- BNC socket wrench
- 5mm hexagon socket wrench



WARNING

Ensure that the power supply is cut off before disassembling the instrument. Only well-trained professional personnel or qualified personnel are allowed to disassemble the instrument.

Exploded View Drawing

You need to get a basic understanding of the main parts of the instrument before disassembling and assembling the instrument. When disassembling or assembling the instrument, please follow the procedures and avoid scratching the part surface. This manual mainly introduces the disassembly and assembly methods of DS1000Z-E series digital oscilloscope. The exploded view of DS1000Z-E (take DS1202Z-E as an example) is as shown in Figure 1-1.

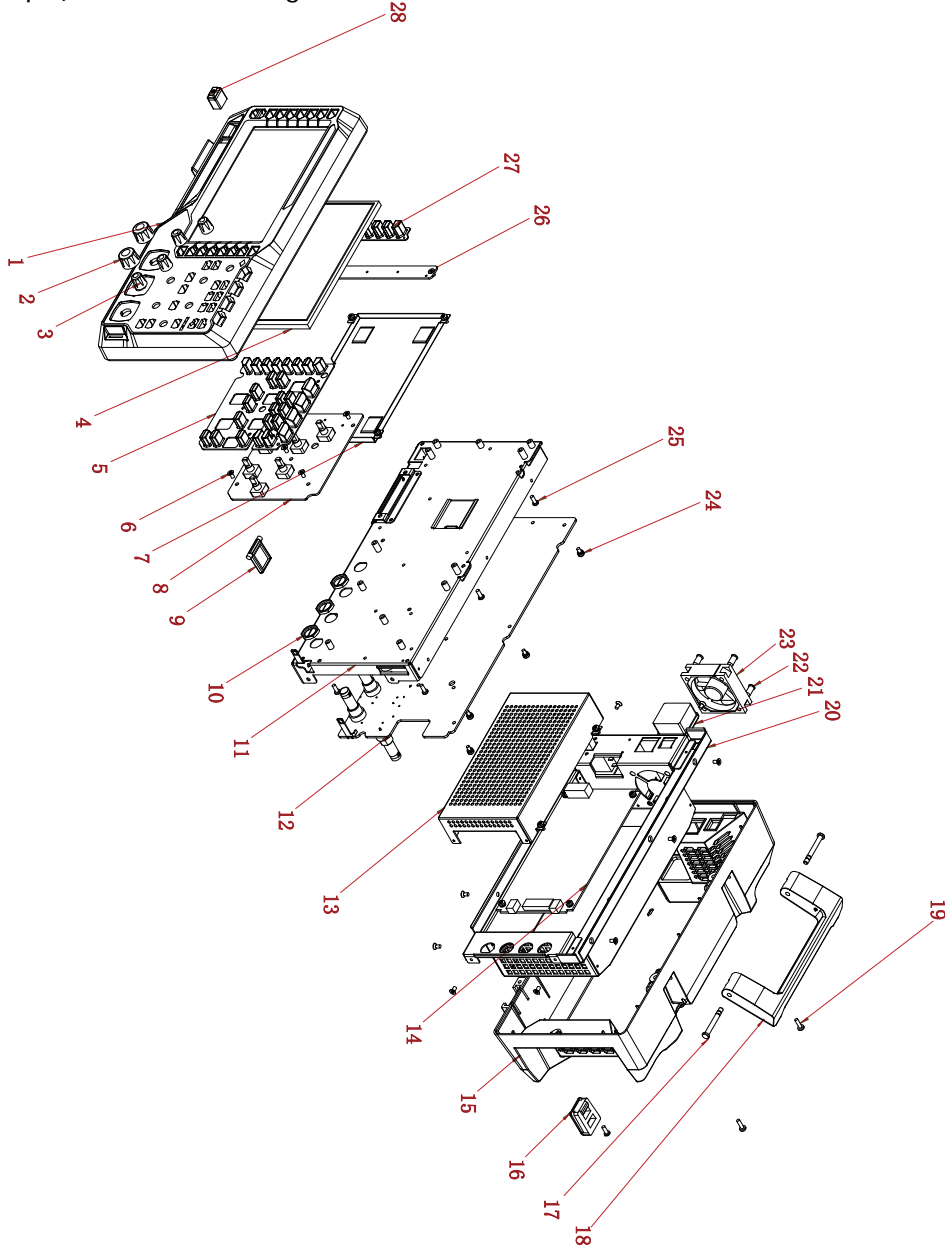

Figure 1-1 Exploded View of DS1000Z-E

Table 1-1 Replacement Parts List

No.	Part No.	Qty.	Name/Description
1	2010001921	1	Front Panel
2	2010000298	2	Large Knob
3	2010000315	4	Small Knob
4	2010003393	1	LCD
5	1020002199	1	Rubber Keypad
6	1020000579	18	M3x6 Torx Flat Head Countersunk Screw
7	1020001117	1	LCD Shield
8	2010002201	1	PCB Board of Rubber Keypad
9	2010000979	2	Bracket
10	1020000619	4	BNC Nut
11	1020002186	1	Metal Front Panel
12	2010004548	1	Main Board
13	1020001121	1	Power Supply Shield
14	2010004439	1	Power Supply Board
15	2010003358	1	Rear Panel
16	(Rear Panel Combination)	2	Rear Bracket
17		2	Handle Shaft
18		1	Handle
19	1020000550	2	M3x10 Torx Pan Head Screw
20	1020002185	1	Metal Rear Panel
21	1010003701	1	Power Cord Connector
22	1020003652	4	BTF5x10 Torx Flat Countersunk Head Self-tapping Screw
23	1020004367	1	Fan
24	1020000571	19	M3x6 Torx Pan Head Combination Screw
25	1020000589	9	M3x8 Torx Pan Head Self-tapping Screw
26	2010004388	1	PCB Board of Keypad at the Left Side of Screen
27	1020002198	1	Rubber Keypad at the Left Side of Screen
28	2010001920	1	Power Key

The recommended disassemble procedures are as follows:

Disassemble the Rear Panel → Disassemble the Metal Rear Panel → Disassemble the Knob → Disassemble the Front Panel → Disassemble the Keypad Board and LCD → Disassemble the Main Board

Disassemble the Rear Panel

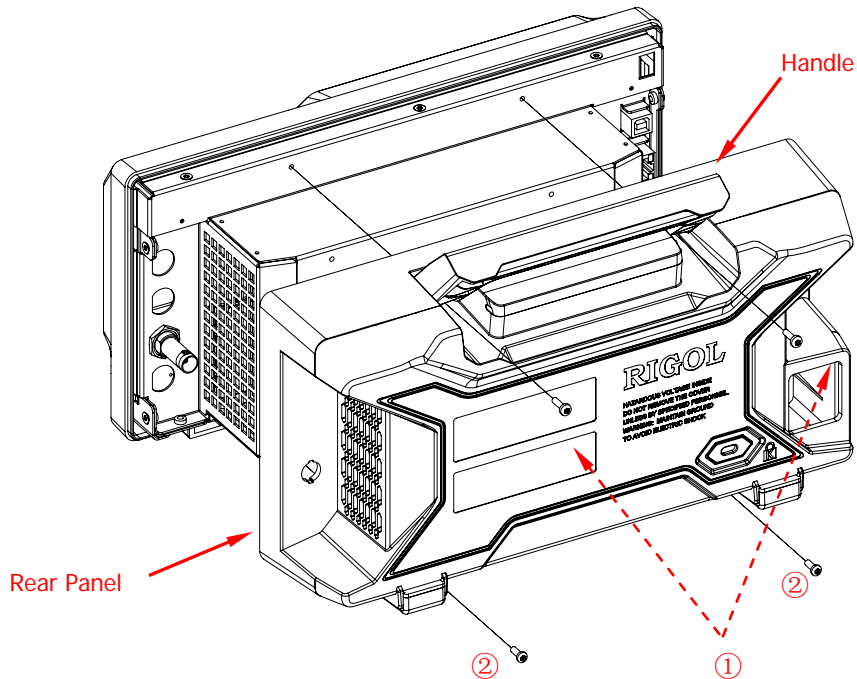

Figure 1-2 Disassemble the Rear Panel

Part Description:

- ① 2 screws (M3x10 torx pan head screw, used for fastening the handle)
- ② 2 screws (M3x8 torx pan head self-tapping screw, used for fastening the brackets of the rear panel)

Disassembly Steps:

1. Use the T10 screwdriver to remove 2 screws (①) that secure the handle.
2. Use the T10 screwdriver to remove 2 screws (②) at the bottom of the rear panel.
3. Remove the rear panel gently.

Disassemble the Metal Rear Panel

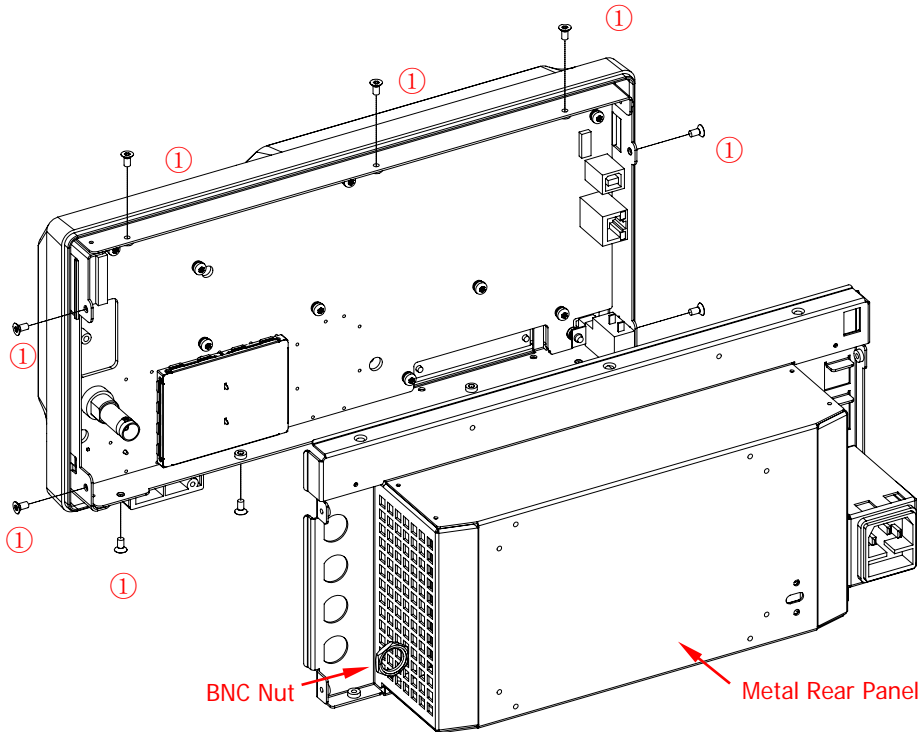

Figure 1-3 Disassemble the Metal Rear Panel

Part Description:

- ① 11 screws (M3x6 torx flat head countersunk screw, used for fastening the metal front panel and the metal rear panel); not all screws are indicated in the above figure.

Disassembly Steps:

1. Use the BNC socket wrench to remove 1 nut and washer at the BNC port on the metal rear panel.
2. Use the T10 screwdriver to remove the 11 screws (①) that secure the metal front metal panel and the metal rear panel.
3. Remove the power cable and fan cable from the main board and take off the metal rear panel gently.

Tip:

- Before disconnecting the power cable and the fan cable from the main board, pay attention to the connecting positions of the cables to avoid incorrect connection or incomplete connection when assembling the cables.
- Before assembling the metal rear panel, check whether the screen cable and keyboard cable on the main board are properly installed.

Disassemble the Knob

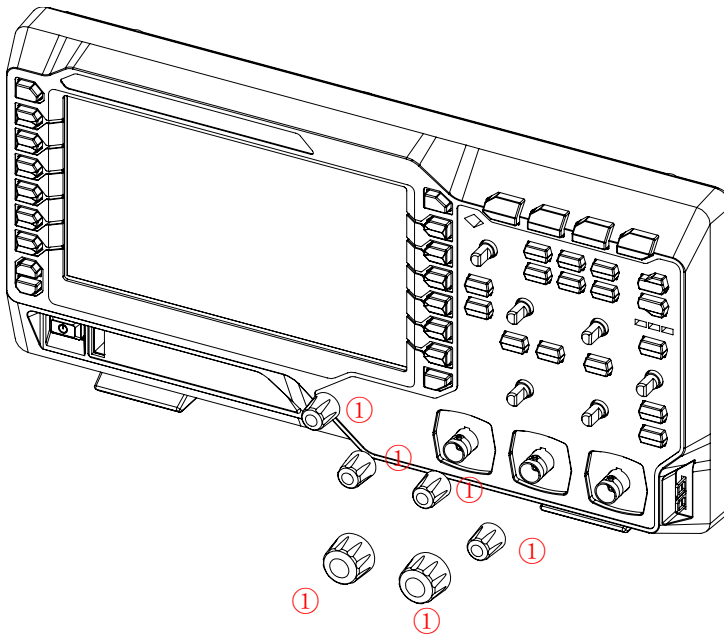

Figure 1-4 Disassemble the Knob

Part Description:

① 6 knobs

Disassembly Step:

Remove the 6 knobs (①) from the front panel.

Tip:

It is recommended that you use a lever-like tool to pry out the knob when disassembling the knob and place a soft pad at the force bearing point to avoid damaging the key film and knob.

Disassemble the Front Panel

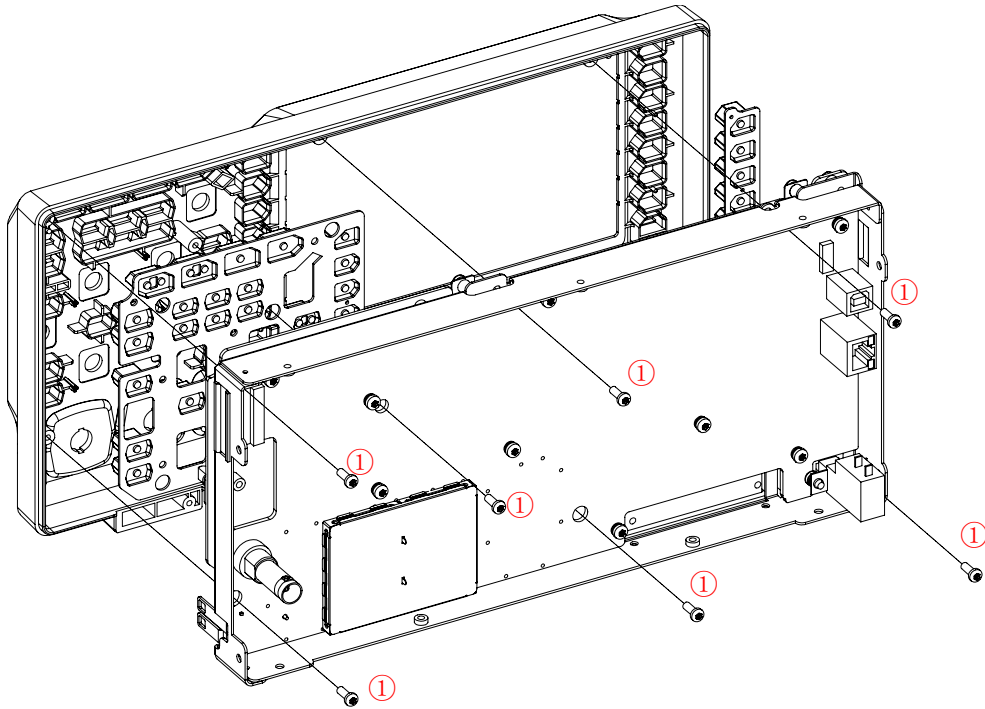

Figure 1-5 Disassemble the Front Panel

Part Description:

- ① 7 screws (M3x8 torx pan head self-tapping screw, used for fastening the front panel)

Disassembly Steps:

1. Use the T10 screwdriver to remove 7 screws (①) that secure the front panel.
2. Take off the front panel gently.

Disassemble the Keypad Board and LCD

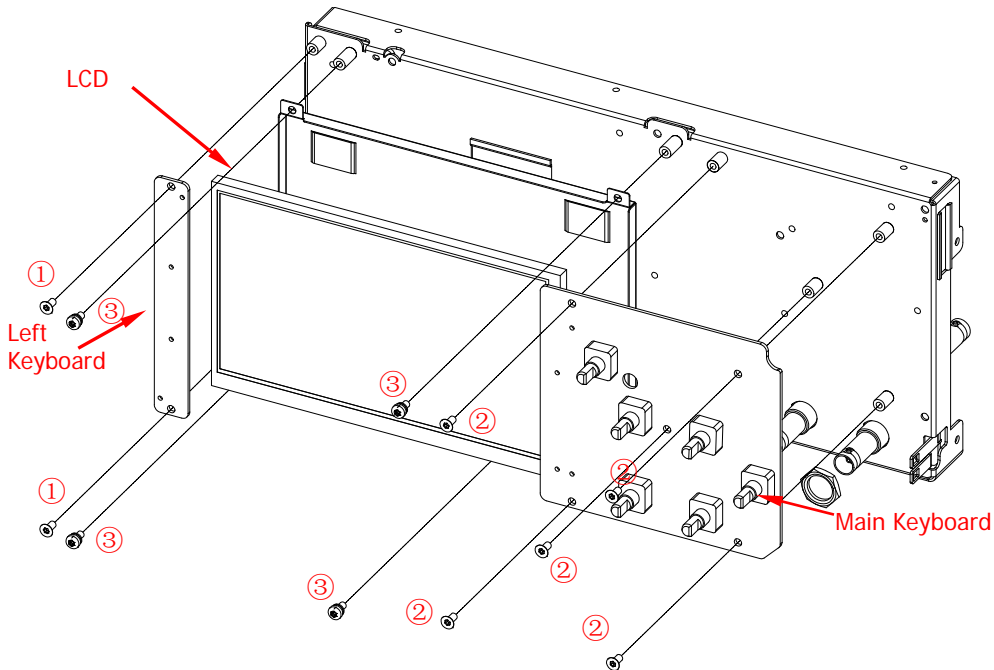

Figure 1-6 Disassemble the Keypad Board and LCD

Part Description:

- ① 2 screws (M3x6 torx flat head countersunk screw, used for fastening the left keyboard)
- ② 5 screws (M3x6 torx flat head countersunk screw, used for fastening the main keyboard)
- ③ 4 screws (M3x6 torx pan head combination screw, used for securing the LCD)

Disassembly Steps:

1. Use the T10 screwdriver to remove 2 screws (①) that secure the left keyboard.
2. Use the T10 screwdriver to remove 5 screws (②) that secure the main keyboard.
3. Remove the left keyboard cable and main keyboard cable from the main board, and take off the left keyboard and main keyboard gently.
4. Use the T10 screwdriver to remove 4 screws (③) that secure the LCD. Remove the screen line from the main board. Take off the LCD gently.

Tip:

- Before disconnecting the keyboard cable and screen cable from the main board, pay attention to the connecting positions of the cables to avoid incorrect connection or incomplete connection when assembling the cables.
- When assembling the keypad boards and LCD, pass the left keyboard cable, main keyboard cable, and screen line through the corresponding holes on the metal front panel. Fasten the main board and then get the cables into proper positions.

Disassemble the Main Board

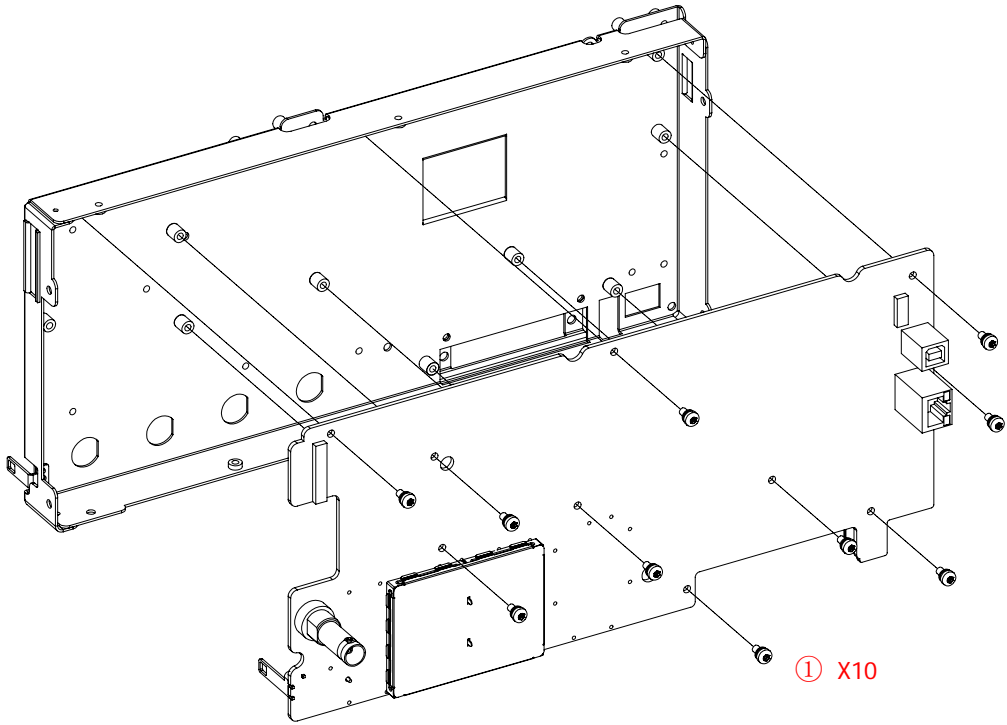

Figure 1-7 Disassemble the Main Board

Part Description:

- ① 10 screws (M3x6 torx pan head combination screw, used for fastening the main board to the metal front panel); please remove them according to their actual positions).

Disassembly Steps:

1. Use the BNC socket wrench to remove the 3 nuts and washers at the BNC ports on the metal front panel.
2. Use the T10 screwdriver to remove 10 screws (①) that secure the main board and the metal front panel.
3. Take off the main board gently.

Assembly Procedures

The assembly procedures are simply the reversal of the disassembly procedures. Check whether the cables are correctly connected and whether all the screws are installed after completing each assembly procedure.

Chapter 2 Troubleshooting&Maintenance

Troubleshooting

The commonly encountered failures and their solutions are listed below. When you encounter those problems, please solve them following the corresponding steps. If the problem persists, please contact **RIGOL** and provide your device information (acquisition method: **Utility** → **System** → **System Info**).

1. The screen is still dark after pressing the power key.

- (1) Check whether the power switch is really on.
- (2) Check whether the power is correctly connected.
- (3) Check whether the fuse is burned out. If the fuse needs to be changed, please use the specified fuse.
- (4) Restart the instrument after finishing the above inspections.
- (5) If it still does not work correctly, please contact **RIGOL**.

2. The signal is sampled but no waveform of the signal is displayed.

- (1) Check whether the probe is correctly connected to the item to be tested.
- (2) Check whether there are signals generated from the item to be tested (you can connect the probe compensation signal to the problematic channel to determine which has problem, the channel or the item to be tested).
- (3) Resample the signal.

3. The measured voltage amplitude is greater or lower than the actual value (this problem usually occurs when probe is used).

Check whether the probe ratio of the channel complies with the attenuation ratio of the probe.

4. There is waveform display but not stable.

- (1) Check the trigger source: press **MENU** → **Source** in the trigger control area (TRIGGER) at the front panel to check whether the trigger source selected complies with the signal channel actually used.
- (2) Check the trigger type: general signals should use "Edge" trigger and video signal should use "Video" trigger. Only when the proper trigger type is used, can the waveform be displayed stably.
- (3) Check the trigger level: adjust the trigger level to the middle of the signal.
- (4) Change the trigger holdoff setting.

5. No display after pressing **RUN/STOP.**

Check whether the trigger mode in the trigger control area (TRIGGER) at the front panel is "Normal" or "Single" and whether the trigger level exceeds the waveform range. If yes, set the trigger level to the middle or set **MODE** to "Auto".

Note: Using **AUTO** could automatically finish the above setting.

6. The display of waveform is ladder-like.

- (1) The horizontal time base might be too low. Increase the horizontal time base to increase the horizontal resolution and improve the display.
- (2) If the display type is "Vectors", the lines between the sample points may cause ladder-like display. Press **Display** → **Type** to set the display type to "Dots" to solve the problem.

7. Fail to connect PC or PictBridge printer through USB.

- (1) Press **Utility** → **IO Setting** → **USB Device** to check whether the current setting matches the device currently connected.
- (2) Check whether the USB cable is correctly connected to the oscilloscope and PC.
- (3) Check whether the USB cable is in good condition. If needed, restart the oscilloscope.

8. The USB storage device cannot be recognized.

- (1) Check whether the USB storage device can work normally.
- (2) Make sure that the USB storage device being used is flash storage type. This oscilloscope does not support hardware storage type.
- (3) Make sure whether the capacity of the USB storage device is too large. It is recommended that the capacity of the USB storage device being used with this oscilloscope is no larger than 8 GBytes.
- (4) Restart the instrument and then insert the USB storage device to check it.
- (5) If the USB storage device still cannot be used normally, please contact **RIGOL**.

Maintenance

System Maintenance

In order to ensure the performance and prolong the service life of the instrument, please follow the recommendations below.

1. Get a full understanding of the performance and basic operating method of the instrument before using it.
2. In order to ensure the measurement accuracy and the service life of the instrument, the instrument should be used and stored in places away from dust, shock, moisture, magnetic field and static; besides, the instrument should be placed in places where it will not be exposed to sunlight for long periods of time.
3. Do not operate the instrument when failure occurs. In this situation, you need to first solve the failure. Besides, regular test and calibration should be performed to ensure the accuracy of the performance.
4. Arrange the instrument properly after you finish the operation of the instrument.
5. Keep the relative accessories of the instrument properly for future use.

Warranty

RIGOL (SUZHOU) TECHNOLOGIES INC. (hereinafter referred to as **RIGOL**) warrants that the product will be free from defects in materials and workmanship within the warranty period. If a product proves defective within the warranty period, **RIGOL** guarantees free replacement or repair for the defective product.

To get repair service, please contact with your nearest **RIGOL** sales or service office.

There is no other warranty, expressed or implied, except such as is expressly set forth herein or other applicable warranty card. There is no implied warranty of merchantability or fitness for a particular purpose. Under no circumstances shall **RIGOL** be liable for any consequential, indirect, ensuing, or special damages for any breach of warranty in any case.

Care and Cleaning

Care

Do not store or leave the instrument where it may be exposed to direct sunlight for long periods of time.

Cleaning

Clean the instrument regularly according to its operating conditions.

1. Disconnect the instrument from all power sources.
2. Clean the external surfaces of the instrument with a soft cloth dampened with mild detergent or water. Avoid having any water or other objects into the chassis via the heat dissipation hole. When cleaning the LCD, take care to avoid scarifying it.



CAUTION

To avoid damage to the instrument, do not expose it to caustic liquids.



WARNING

To avoid short-circuit resulting from moisture or personal injuries, ensure that the instrument is completely dry before connecting it to the power supply.

Environmental Considerations

The following symbol indicates that this product complies with the WEEE Directive 2002/96/EC.



Product End-of-Life Handling

The equipment may contain substances that could be harmful to the environment or human health. To avoid the release of such substances into the environment and avoid harm to human health, we recommend you to recycle this product appropriately to ensure that most materials are reused or recycled properly. Please contact your local authorities for disposal or recycling information.