

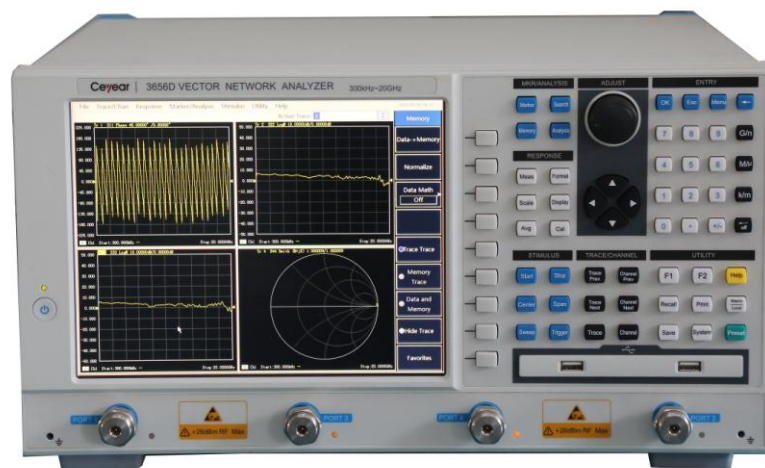

3656 Series Vector Network Analyzer Programming Manual



Foreword

Thank you for choosing and using 3656 series vector network analyzer developed and produced by China Electronics Technology Instruments Co., Ltd! Please read carefully this manual before use.

Taking maximally meeting your demands as our responsibility, we will provide you with quality measuring instruments and supreme after-sales services. With the consistent tenet of “superior quality and considerate services”, we are committed to providing users with satisfactory products and services. You’re welcome to contact us if you have any questions:

Tel: +86-0532-86896691

Web: www.ceyear.com

Email: sales@ceyear.com

Address: No. 98, Xiangjiang Road, Qingdao City, China

Zip code: 266555

This manual mainly introduces how the 3656 series vector network analyzer produced by China Electronics Technology Instruments Co., Ltd. (CETI) uses external control computers for program control via GP-IB interfaces or LAN interfaces and provides corresponding routines to help you get familiar with and master the program control methods and commands of the instrument.

Due to tight schedule and limited ability of the author, there might be some inevitable errors or omissions in this manual, so please do not hesitate to give your comments if you find such problems! We apologize for any inconvenience possibly caused by our mistakes.



Statement:

This manual is the first version of the Programming Manual for 3656 Series Vector Network Analyzer, and the version number is A.1.

The contents hereof are subject to change without notice. CETI reserves the right of interpretation for the contents and the terms used herein.

CETI holds the copyright of this manual. No organization or individual is allowed to modify or alter the contents herein or copy or distribute this manual for the purpose of profit without the authorization of the company. CETI reserves the right to pursue legal liability for the infringers.

July, 2018

Contents

Chapter 1 Remote Programming Fundamentals	1
Section 1 Programming and Software/Hardware Layers	2
Section 2 Remote Control Ports of the Network Analyzers and Configuration	3
Section 3 I/O Library and Programming Languages	5
Chapter 2 SCPI Fundamentals	6
Section 1 Introduction of SCPI.....	7
Section 2 General Terms of SCPI.....	8
Section 3 Syntax of SCPI Commands	9
Section 4 Types of SCPI Commands	11
Section 5 Command Tree of SCPI.....	12
Section 6 Parameters and Responses of SCPI Commands.....	13
Section 7 Program Messages of SCPI Commands	16
Section 8 Numeral Systems in SCPI Commands.....	17
Chapter 3 Reference of SCPI Commands.....	18
IEEE 488.2 Common Commands.....	18
Abort Commands	20
CALC:BLIMIT command	21
Calc:CONVersion commands	25
Calc:Correction Command.....	26
Calc:Data Command.....	28
Calc:Filter Command	33
Calc:Format Command.....	37
Calc:Function Commands.....	38
Calc:Limit Commands	46
Calc:Marker Commands	54
Calc:Math Commands	74
Calc:MStatistics Commands	75
Calc:Normalize Commands	77
Calc:Parameter Commands.....	79
Calc:RData Commands	83
Calc:RLimit Commands	84
Calc:Smoothing Commands	88
Calc:Transform Commands	89
Display Commands	95
Format Commands	120
Hardcopy Commands	122
Initiate Command.....	122
Memory Command.....	124
Output Commands.....	138

Sens:Average Commands	139
Sense:Bandwidth Commands.....	140
Sense:Correction Commands.....	141
Sense:Correction:Collect:CKit Commands.....	168
Sense:Correction:CSET Commands	197
Sense:Correction:Collect:Guided Commands.....	200
Sense:Couple Commands	205
Sense:Frequency Commands	206
Sense:Power Commands	209
Sense:Roscillator command	210
Sense:Segment Commands	210
Sense:Sweep Commands	220
Service Commands.....	226
Source Commands	230
Source:Power:Correction Commands	237
Status Register Commands	252
System Commands.....	292
Trigger Commands	299
Chapter 4 Error Description	306
Section 1 Overview of Error Messages	307
Section 2 Formats of Error Messages	308
Section 3 Type of Error Messages.....	309
Section 4 Details of error messages.....	310
Chapter 5 Programming Examples	369
Query all measurements with SCPI commands	369
Use SCPI Command to create a measurement	370
Set Sweep Parameters Using SCPI	370
Setup the Display Parameters Using SCPI	371
Use SCPI commands to perform 2-port calibration	372
Use SCPI commands to read-write data	374
Use SCPI commands to correct calibration kit	375
GBIP Using VC++	377
Annex A Commands List	382

Chapter 1 Remote Programming Fundamentals

This chapter describes fundamentals about remote programming and the configuration of the remote ports of the vector network analyzer.

- ◆ Programming and software/hardware layers
- ◆ Remote control ports of the vector network analyzer and configuration
- ◆ I/O library and programming language

Section 1 Programming and Software/Hardware Layers

3656 series vector network analyzer supports the following programming interfaces: GPIB and LAN. These interfaces can be used with I/O libraries and programming languages for remote control of vector network analyzer. Figure 1-1 shows the relationship between interfaces, I/O libraries, programming languages and vector network analyzer with GPIB as an example.

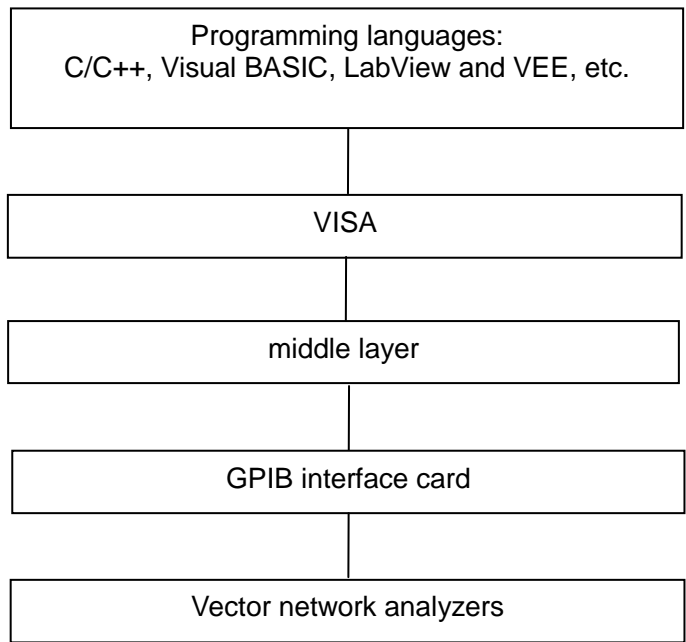

Figure 1-1 Software/hardware Layers

Section 2 Remote Control Ports of the Network Analyzers and Configuration

1.2.1 GPIB interface

The GPIB interface, which was first proposed for program control of instrument, is still widely used. Various instruments are connected together via GPIB and can be controlled by computers. GPIB and its related associated interface operations are defined and described in detail in ANSI/IEEE Standard 488.1-1987 and ANSI/IEEE Standard 488.2-1992. For details of the standard, please refer to IEEE website at <http://www.ieee.org>.

GPIB processes information in bytes at the data transmission speed of up to 8MBps, which is fast. GPIB is limited by the distance between the device/system and the computer, so the maximum length of the transmission cable is 20 meters. In general, the maximum length between the devices cannot exceed 2 meters.

1.2.1.1 GPIB interface setting

The setting of GPIB interfaces mainly involves the setting of the GPIB addresses, which can be made from **GPIB Address** in the **System** menu.

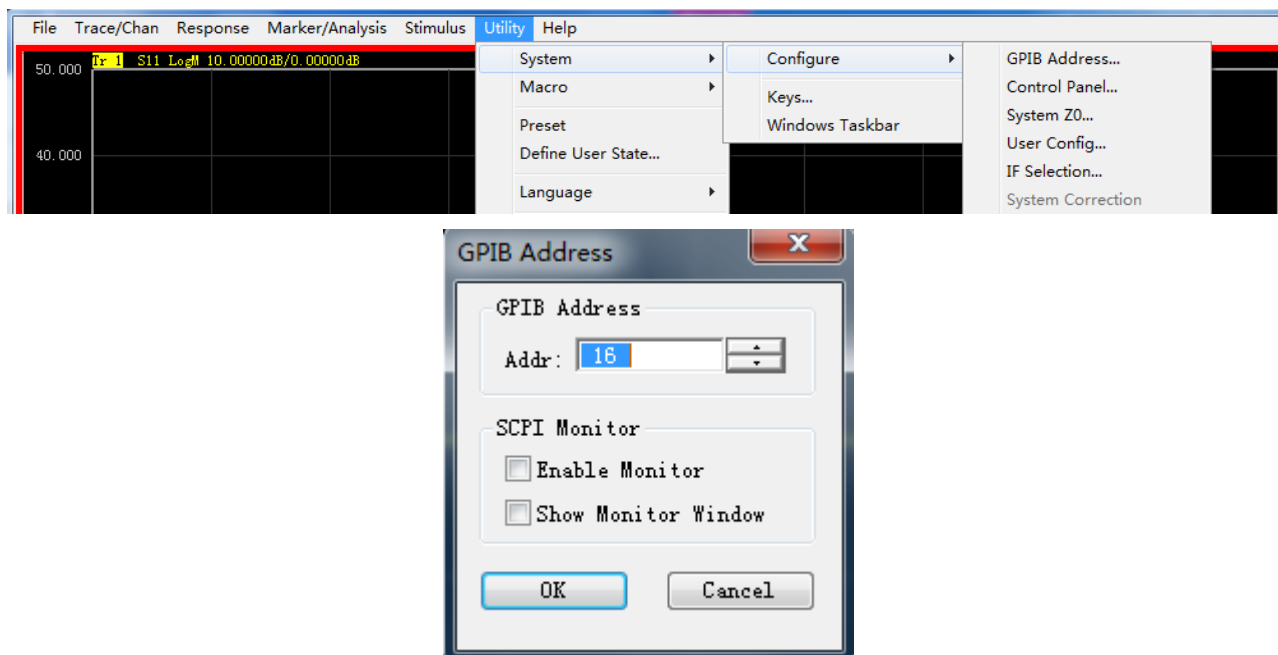

Figure 1-2 GPIB Interface Setting

Note: When there is more than one vector network analyzers in the system, the GPIB address of each analyzer should be different; the default address is 16.

1.2.2 LAN interface

The vector network analyzer can be remotely controlled by computers in the 10Base-T and 100Base-T LANs, which can connect various instruments to be controlled by computers in the networks. For definitions of LAN and its interface operations, please refer to IEEE 802.2 and <http://www.ieee.org>.

Data transmission in the LANs is very fast due to the grouping. The cable length between the computer and the vector network analyzer should not exceed 100 meters (100Base-T and 10Base-T). For more information about LAN communication please refer to: <http://www.ieee.org>.

The host computer can communicate with the vector network analyzer over a LAN using the following protocols:

- ◆ Sockets

1.2.2.1 LAN interface setting

When remotely controlling vector network analyzers over a LAN, the physical connection of the network should be ensured. And the IP addresses of the vector network analyzers should be set correctly.

Note Make sure the vector network analyzers are in normal physical connection via

100Base-T LAN or 10Base-T LAN cables.**1.2.2.2 Using LAN sockets**

The TCP/IP protocol connects the vector network analyzers to the network via LAN sockets. Socket is a basic method used in computer network programming that enables applications using different hardware and operating systems to communicate in the network. This method allows for two-way communication between the vector network analyzers and the computers via ports.

A socket is a specially-written software class that defines IP addresses and device port numbers and integrates some basic operations in network programming. Sockets can be used after installing packaged libraries in the operating system. Two commonly used socket libraries are the Berkeley socket library for UNIX the Winsock library for Windows.

Sockets in vector network analyzers are compatible with Berkeley socket and Winsock through application programming interfaces (APIs). They are also compatible with other standard socket APIs. Vector network analyzers can be controlled with SCPI commands, which are issued by socket programs established in the program.

The socket port numbers of the vector port analyzers must be selected before using LAN sockets.

Note This socket port number for series of vector network analyzers is 1024, which is used for SCOKET network programming. Please note when programming through a network that a terminator must be added at the end of a transfer, otherwise, multiple packets may be received together and cannot be distinguished.

Note When programming with a visa library, it is required to set the property VI_ATTR_TERMCHAR_EN to TRUE and the reading to be ended after receiving the terminator.

Section 3 I/O Library and Programming Languages

An I/O library is a collection of functions that are used to send commands and receive device data to the device. I/O libraries must be installed before the interacting with and controlling the vector network analyzers. For the installation and configuration of I/O libraries, please refer to the enclosed documentation of the control card and I/O library you have selected.

Note Before using a computer controlled vector network analyzer, please verify that you have properly installed and configured necessary ports and I/O libraries.

Vector network analyzers can be remotely controlled through the use of Standard Commands for Programming Instructions (SCPI), IO library functions and programming languages. Common programming languages include:

- ◆ C/C++
- ◆ C#
- ◆ LabView
- ◆ Visual Basic® (Visual Basic is a registered trademark of Microsoft)
- ◆ Agilent VEE

Chapter 2 SCPI Fundamentals

This chapter describes how SCPI messages are organized and expressed and provides an overview of the SCPI language.

- ◆ Introduction of SCPI
- ◆ General Terms of SCPI
- ◆ Syntax of SCPI Commands
- ◆ Types of SCPI Commands
- ◆ Command Tree of SCPI
- ◆ Parameters and Responses of SCPI Commands
- ◆ Program Messages of SCPI
- ◆ Numeral Systems in SCPI Commands

Section 1 Introduction of SCPI

The program messages, response messages, status report structures, and data formats of defined standardized SCPI instruments are only relevant to instrument test functions as well as their performance and accuracy without regard to instrument hardware composition, manufacturers, physical communication connection hardware environment and programming environment of test programs.

- (1) The program commands target test functions (signals) instead of describing instrument operations.
- (2) Control methods to reduce similar test functions are the key to ensuring programming compatibility.
- (3) Program messages are defined at a high level independent of the hardware of the communication physical layer.
- (4) Irrelevant to programming means and programming languages, SCPI test programs are easily transplanted.
- (5) Being contractile, thus applicable to measurement control of different scales.
- (6) SCPI have been a “living” standard for their scalability.

Section 2 General Terms of SCPI

The following terms will be used throughout the rest of this section. In order to better understand the content hereinafter, you need to understand the exact definitions of these terms.

Controller

A controller is any computer used to communicate with the SCPI device. A controller may be a PC, a small computer, or a card on the card cage. Some AI devices can also be used as controllers.

Device

A device is any device that supports SCPI. Most of the devices are electronic measurement or excitation devices that use GPIB interfaces for communication.

Program message

A program message is the combination of one or more SCPI commands that have been correctly formatted. Program messages tell the devices how to measure and output the signals.

Response message

A response message is a set of data of specified SCPI formats. Response messages always come from the devices or listening devices. Response messages tell the controllers about the internal state or measured values of the devices.

Command

A command is an instruction that satisfies the SCPI standard. The combination of commands controlling the devices forms a message. In general, a command includes keywords, parameters, and punctuation.

Event command

Some commands are events and cannot be queried. An event has no corresponding settings and it triggers an action at a specific moment.

Query

A query is a special type of command. A query controls the devices to generate response messages meeting the requirements of the controllers. A query statement always ends with a question mark.

Section 3 Syntax of SCPI Commands

A typical command consists of a keyword prefixed with a colon. The keyword is followed by parameters. The following is an example of a syntax declaration:

```
[[:SOURce]:POWer[:LEVel] MAXimum|MINimum
```

In the example above, the [:LEVel] in the command follow: POWer closely without any space. Following the [:LEVel], MINimum|MAXimum is a parameter (description of the command expressions). There is a space between the command and its parameter. Conventions of other parts of the syntax expression are shown in Tables 2-1 and 2-2.

Table 2-1 Special characters in the command syntax

Symbol	Meaning	Example
	The vertical between the keyword and the parameter means another choice. When used in a parameter, the effect of a command changes with the selection.	[[:SOURce]:AM: SOURce EXTernal INTernal EXTernal and INTernal are choices
[]	Square brackets indicate that the attached keyword or parameter is optional when constructing the command. These implied keywords or parameters will be executed even if they are ignored.	[[:SOURce]:AM[:DEPTTh]:EXPonential? SOURce and DEPTTh are optional
<>	The angle brackets around a word indicate that the word is not used literally in the command. Instead, it represents the required item.	[[:SOURce]:FREQ:STOP <val><unit> In this command, <val> and <unit> must be replaced by the real frequency and unit :FREQ:STOP 3.5GHz
{}	The braces indicate that these parameters can be optionally used in commands once, several times, or not used at all.	[[:SOURce]:LIST:POWer <val>{,<val>} Single power column LIST:POWer 5

Table 2-2 Command syntax

Characters, keywords and syntax	Example
Uppercase characters represent the minimum set of characters required to execute a command.	[:SOURce]:FREQuency[:CW]?, FREQ is the minimum part needed.
The lowercase character portion of the command is optional; it can be included in the uppercase portion of the command or ignored. This flexible format is called "flexible listening". See the section "Parameters and Responses of Commands" for more information.	:FREQuency :FREQ,:FREQuency or :FREQUENCY, Either is of them is correct.
When a colon is between the two command mnemonics, it moves the current path in the command tree down by one level. For more information, please refer to the command path part in section "Command Tree".	:TRIGger:OUTPut:POLarity? TRIGger is the topmost keyword of this command.
If the command requires more than one parameters, you need to separate the adjacent parameters with a comma. The parameter is not part of the command path, so it does not affect the levels of the path.	[:SOURce]:LIST:DWELI <val>{,<val>}
The semicolon separates two commands of the same program message and does not affect the current path.	:FREQ 2.5GHZ; :POW 10DBM
Blank characters, such as <space> or <tab>, are usually ignored as long as they do not appear between keywords or in keywords. However, you must separate the commands and parameters with blank characters, which does not affect the current path.	:FREQ uency or :POWer :LEVel is not allowed. There must be a space between: LEVel and 6.2. :POWer:LEVel 6.2

Section 4 Types of SCPI Commands

Commands can be divided into two types: common commands and subsystem commands. Figure 2-1 shows the differences between the two types. Common commands, defined by IEEE 488.2, are used to manage macros and status registers and for synchronization and data storage. They all start with an asterisk, so it's easy to recognize them. For example, *IDN? , *OPC, *RST are all common commands. Generic commands do not belong to any subsystem, and signal generators interpret them in the same way, regardless of the current path settings. Subsystem commands are easily recognizable for containing colons (:). A colon is used in the beginning of an expression or between two keywords, for example: FREQUency[:CW?]. Each command subsystem is a set of commands roughly corresponding to a functional module within the signal generator. For example, the power subsystem (:POWer) contains power generating commands, while the state subsystem (:STATus) contains commands that control the status registers.

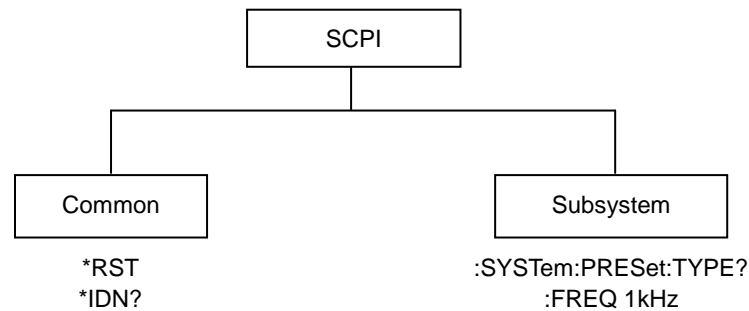

Figure 2-1 Types of SCPI Commands

Section 5 Command Tree of SCPI

Most programming tasks involve subsystem commands. In most computers, SCPI use a structure similar to a file system for subsystem commands. In SCPI, this command structure is called a command tree, as shown in Figure 2-2:

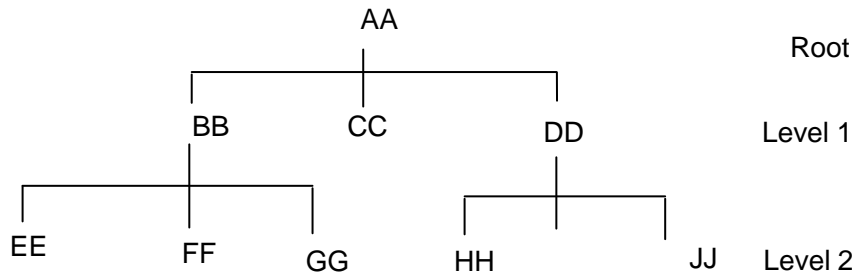

Figure 2-2 Simplified command tree

The command on the top is the root command, which is, simply speaking, the "root". You must go to the next level of commands based on a specific path. In the example below: POWER stands for AA, :ALC stands for BB, and :SOURce stands for GG. The entire command path is: POWER: ALC: SOURce? (:AA:BB:GG).

In order to access commands in the command tree from different paths, you must understand how the device interprets the commands. A special component in the device software, *the interpreter*, is responsible for decoding every message sent to the device. The compiler uses a series of rules that identify the paths of the command tree to divide a message into separate command elements. When you send the next command, the compiler keeps tracking of the *current path*, namely, the corresponding level in the command tree. This is important because the keywords in the same command may appear in different paths, and the specific path you use determines the interpretation of the keywords of the command.

After booting or *RST (reset), the current path is set to root.

Section 6 Parameters and Responses of SCPI Commands

SCPI define different data formats in the use of program and response messages to comply with the principles of "*flexible listening*" and "*precise speaking*". For more information, please refer to IEEE488.2. "*Flexible listening*" means that the formats of the commands and parameters are flexible.

For example, command:FREQuency:OFFSet:STATe ON|OFF|1|0, signal generator receiving

:FREQuency:OFFSet:STATe ON, :FREQuency:OFFSet:STATe 1,

:FREQ:OFFS:STAT ON, :FREQ:OFFS:STAT 1, both setting frequency offset on.

Each parameter type corresponds to one or more response data types. When queried, a numeric parameter will return a real or integer response data. The response data are accurate, which is rigorously called "*precise speaking*."

"*Precise speaking*" means that the response format for a specific query is the same.

For example, if you query the power state (:POWER:ALC:STATe?), when it is on, the response is always 1 whether have sent: POWER:ALC:STATE 1 or :POWER:ALC:STATe ON.

Table 2-3 Types of parameters and responses

Parameter type	Response data type
Numerical	Real number or integer
Extended numerical	Integer
Discrete	Discrete
Boolean	Digital boolean
String	String
Blocks	Finite-length blocks
	Infinite-length blocks
Non-decimal numeric types	Hexadecimal
	Octal
	Binary

Numerical parameters

Numeric parameters can be used in both subsystem commands and common commands. Numeric parameters receive all common decimal notations, including positive/negative signs, decimal point, and scientific notation. If a device only accepts a specified numeric type, such as an integer, it will automatically round up the received numeric parameters.

The following are examples of numeric parameters:

0	No decimal point
100	Optional decimal point
1.23	Signed bit
4.56e<space>3	Index mark e can be followed by a space
-7.89E-01	Index marker e can be uppercase or lowercase
+256	Positive lookahead allowed
5	Decimal points can be used first

Extended numerical parameters

Most subsystem-related measurements use extended numeric parameters to specify physical quantities. Extended numerical parameters receive all numeric parameters and additional special values. All extended numeric parameters receive MAXimum and MINimum as values. Other special values, such as UP and DOWN, depend on the command table of the device to judge whether to receive above values, and all valid parameter suffixes are listed in the SCPI command table. Note: Extended numeric

parameters do not apply to common commands or subsystem command STATus.

Examples of extended numeric parameters:

101	Numeric parameter
1.2GHz	GHz can be used as an index (E009)
200MHz	MHz can be used as an index (E006)
-100mV	-100 millivolts
10DEG	10 degrees
MAXimum	Maximum effective setting
MINimum	Minimum effective setting
UP	Increase by a step
DOWN	Reduce by a step

Discrete parameters

When the number of parameter values to be set are finite, they are identified by discrete parameters. Discrete parameters use mnemonics to represent each valid setting. Like program command mnemonics, discrete parameter mnemonics have two formats, long and short, and allows for mixture of upper and lower cases.

In the following example, discrete parameters are used with commands:

```
:TRIGger[:SEquence]:SOURce BUS|IMMEDIATE|EXTernal
```

BUS GPIB, LAN, RS-232 trigger

IMMEDIATE Trigger immediately

EXTernal Trigger externally

Boolean parameters

A Boolean parameter represents a true or false binary condition, which can only have four possible values.

Boolean parameter examples:

ON Logically true

OFF Logically false

1 Logically true

0 Logically false

String parameters

String parameters allow ASCII strings to be sent as parameters. Single quotes and double quotes are used as separators.

The following are example of string parameters:

'This is Valid' "This is also Valid" 'SO IS THIS'

Real response data

Most of the test data are of real number type, and their formats can be basic decimal notation or scientific notation, which are supported by most advanced programming languages.

Examples of real number response data:

1.23E+0

-1.0E+2

+1.0E+2

0.5E+0

0.23

-100.0

+100.0

0.5

Integer response data

An integer response data is a decimal expression of an integer value containing signed bit. When querying the status register, most of the response data returned are of integer type.

Examples of integer response data:

0	Sign bit optional
+100	Positive lookahead allowed
-100	Negative lookahead allowed
256	No decimal point

Discrete response data

Discrete response data are basically the same as discrete parameters, only that the return format of discrete response data is only a short form in uppercase.

Samples of discrete response data:

INTernal	Stabilization mode is internal
EXTernal	Stabilization mode is external
MMHead	Stabilization mode is millimeter wave source module

Digital Boolean response data

A Boolean response data returns a binary value of 1 or 0.

String response data

String response data and string parameters are alike. The main difference is that the separators of string response data are double quotes instead of single quotes. Double quotes can also be embedded in string response data, and there may be no characters between the double quotes. Here are some examples of string response data:

“This is a string”

“one double quote inside brackets: (””)”

Section 7 Program Messages of SCPI Commands

The following commands will be used to express determined program messages:

```
[[:SOURce]:FREQUency:STARt [:SOURce]:FREQUency:STOP
```

```
[[:SOURce]:FREQUency[:CW] [:SOURce]:POWer[:LEVel]:OFFSet
```

Example 1

```
:FREQUency:STARt 500MHZ; STOP 1000MHZ
```

This program message is correct and will not generate any error because STARt and STOP are in the same path bracket. This is equivalent to sending the following message:

```
FREQUency: STARt 500MHZ; FREQUency: STOP 1000MHZ
```

Example 2

```
:POWER 10DBM; :OFFSet 5DBH
```

This program message will generate an error. This message uses a default power node (:LEVel). When using a default node, the current path will not be changed. There is no OFFSet command in the root command layer and an error occurs.

The following example shows the correct usage of this program message:

```
:POWer 10DBM;:POWer:OFFSet 5DB
```

Example 3

```
:POWer:OFFSet 5DB;POWer 10DBM
```

This program message has a command error. The path will drop once after each colon. The first half of the message drops the path of the command to the next level of the command OFFSet, where the command POWer does not exist.

The command POWer 10DBM dropped a lookahead colon, so when the command was sent, the device can not find POWer in the level POWer:OFFSet, which caused the confusion. At this point it is required to add a lookahead colon to reset the current path as the root. The corrected program message is:

```
:POWer:OFFSet 5DB;:POWer 10DBM
```

Example 4

```
FREQ 500MHZ; POW 4DBM
```

In this example, the short format of the keyword is used. This program message is correct because it utilizes the default nodes: FREQ[:CW] and :POW[:LEVel]. Since the default nodes do not affect the current path, it is not necessary to use colons before FREQ and POW.

```
:MMEMory:COpy "FLATCAL@USERFLAT","FLAT_2CAL@USERFLAT"
```

Section 8 Numeral Systems in SCPI Commands

The value of command can be entered in binary, decimal, hexadecimal or octal format. When using binary, hexadecimal or octal format, a proper identifier is required before the value. The decimal format (the default format) does not require an identifier. When a value is entered without an identifier in front of it, the device will ensure it to be in decimal format. The following list shows the identifiers required for different formats:

- #B indicates that this number is a binary value.
- #H indicates that this number is a hexadecimal value.
- #Q indicates that this number is an octal value.

The following are various representations of the decimal number 45 in SCPI commands:

#B101101

#H2D

#Q55

The following example sets the RF output power to 10 dBm (or a value of the equivalent value of the currently selected unit, such as DBUV or DBUVEMF) with a hexadecimal value of 000A.

:POW #H000A

When using a non-decimal format, a measurement unit, such as DBM or mV, is not used with the value.

Chapter 3 Reference of SCPI Commands

This chapter contains all SCPI command information identified and executed by 3656 series vector network analyzers. It mainly contains the following subsystems:

- ◆ IEEE-488.2 Common Commands
- ◆ ABORt Abort scanning
- ◆ CALCulate Channel control command
- ◆ DISPlay Control display setting
- ◆ FORMat data transfer format setting
- ◆ HCOPy Hard copy print control
- ◆ INITiate Triggering settings continuously or manually
- ◆ MMEMory Storeing and recalling instrument status
- ◆ OUTPut Turning on or off the RF source on
- ◆ SENSE Channel control command
- ◆ SOURce Control the power to DUT.
- ◆ SOURce:POWER offer source power calibration
- ◆ STATus Reading Analyzer's Status Registers
- ◆ SYSTem Analyzer's default control
- ◆ TRIGger Starting or ending measurement

IEEE 488.2 Common Commands

- *CLS - Clear Status
- *ESE - Event Status Enable
- *ESE? - Event Status Enable Query
- *ESR? - Event Status Register
- *IDN? - Identify
- *OPC - Operation Complete Command
- *OPC? - Operation Complete Query
- *OPT? - Identify Options Query
- *RST - Reset
- *SRE - Service Request Enable
- *SRE? - Service Request Enable Query
- *STB? - Status Byte Query
- *TST? - Result of Self-test Query
- *WAI - Wait

*CLS - Clear Status

Clear the instrument status, namely: empty error queue and all event register. At the same time cancel all pending *OPC commands and query commands. See Status Register Commands and Reading Analyzer's Status Register.

***ESE - Event Status Enable**

Standard event status enable register set bit. See Status Register Commands and Reading Analyzer's Status Register.

***ESE? - Event Status Enable Query**

Query the standard event enable register. See Status Register Commands and Reading Analyzer's Status Register.

***ESR? - Event Status Register**

Read and empty the event status register. See Status Register Commands and Reading Analyzer's Status Register.

***IDN? - Identify**

Return the unique instrument identification string, which varies with the different models. Such as: "41st Institute of CETC, 3659 Series Vector Network Analyzer, 1.00".

***OPC - Operation Complete Command**

Set OPC bit of the standard event status register, after completing all pending overlapping commands (e.g.: primary sweep or Default command, etc.). See Command Synchronization.

***OPC? - Operation Complete Query**

Return letter "1" after completing all pending overlapping commands. See Command Synchronization.

***OPT? - Identify Options Query**

Return the configuration options string of the instrument.

***RST - Reset**

Perform reset operation, cancel all pending *OPC commands or query commands, the function of which is same as SYSTem:PRESet command. The nonvolatile memory contents of the instrument are not lost.

***SRE - Service Request Enable**

Analyzer requires it must enable the status bit before reading status register. This command enables the service request register bit. The register's current setting value is saved in nonvolatile memory. See Status Register Commands and Reading Analyzer's Status Register.

***SRE? - Service Request Enable Query**

Read Service Request Enable register the current state value. After reading the operating system will clear the register. The return value of each bit is defined by the status register command table query. See also reading analyzer status register.

***STB? - Status Byte Query**

Read instrument status byte. This register is cleared only when its associated registers are empty. See Status Register Commands and Reading Analyzer's Status Register.

***STB? - Result of Self-test Query**

Return the instrument hardware status query value. 0 indicates no failure status. Other values indicate the presence of one or more status as follows. The returned value is the weighted sum of the following status. Such as:

Returning 4 indicates an overload.

Returning 6 indicates instable amplitude and overload.

Bit	Weight	Description	In case of the following status, Position 1 will suffer from
0	1	Phase unlock	Phase unlock. Possible causes: reference channel is on; hardware failure, etc..
1	2	Unleveled	Source power is unleveled. Possible causes: the source power exceeds the tuning range; hardware failure, etc..
2	4	Overload	Input power is too high. Possible causes: the use of an amplifier or hardware failure.
3	8	EEPROM Write Fails	EEPROM write fails. Possible causes: hardware failure.
4	16	YIG Calibration Fails	Unable to calibrate YIG. Possible causes: losing lock or hardware failure.
5	32	Slope calibration failure	Unable to calibrate analog slopes. Possible causes: hardware failure.
6	64	Excessive temperature	Source temperature sensor exceeds the limit value. Possible cause: poor air circulation and fan damage.

***WAI - Wait**

The instrument processes the new commands after completion of processing all the pending overlapping commands. See Command Synchronization.

Abort Commands

Abort

(Write only) End all sweeps - Then sweep again according to the trigger setting of each channel. Abort command and INITiate:IMMediate (restart) command are similar except for cases of single sweep for the channels. In single sweep cases, no sweep will be started again after being ended with the Abort command.

Example

```
ABOR
abort
```

Query Syntax NONE

Overlapping? No

Default NONE

CALC:BLIMIT command

Bandwidth test setting

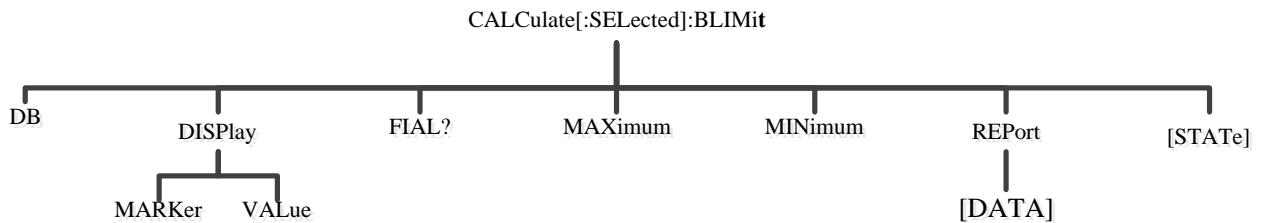

Note: CALCulate command functions on the selected measurement. This channel must have selected a measurement. Use CALC:PAR:SEL command to select the measurement.

CALCulate<cnum>[:SElected]:BLIMit:DB <num>

(Read-Write) Set or query bandwidth threshold of bandwidth test

Parameter

<cnum> Channel number of measurement. This channel must have selected a measurement. If not specified, <cnum> is default to 1.

<num> Bandwidth N dB points. (0~1000)

Example

```
CALC:SEL:BLIM:DB 3;
calculate2:Selected:blimit:db 5;
```

Query Syntax

```
CALCulate<cnum>:BLIMit:DB?
```

Return Type Char

Overlapping? No

Default value 0

CALCulate<cnum>[:SElected]:BLIMit:DISPlay:MARKer <ON | OFF>

(Read-Write) Turn on/off the mark display of bandwidth test.

Parameter

<cnum> Channel number of measurement. This channel must have selected a measurement. If not specified, <cnum> is default to 1.

<ON | OFF> ON (or 1) - Show bandwidth mark
OFF (or 0) - Hide bandwidth mark

Example `CALC:BLIM:DISP:MARK ON`
`calculate2:selected:blimit:display:marker off`

Query Syntax `CALCulate<cnum>:BLIMit:DISPlay: MARKer?`

Return Type `Bool (1 = ON, 0 = OFF)`

Overlapping? `No`

Default `OFF`

CALCulate<cnum>[:SELEcted]:BLIMit:DISPlay:VALue <ON | OFF>

(Read-Write) Turn on/off the bandwidth value display of bandwidth test.

Parameter

<cnum> Channel number of measurement. This channel must have selected a measurement. If not specified, <cnum> is default to 1.

<ON|OFF> ON (1) - Show test bandwidth value
 OFF (0) - Hide test bandwidth value

Example `CALC:BLIM:DISP:VAL ON`
`calculate2:selected:blimit:display:value off`

Query Syntax `CALCulate<cnum>:BLIMit:DISPlay:VALue?`

Return Type `Bool (1 = ON, 0 = OFF)`

Overlapping? `No`

Default `OFF`

CALCulate<cnum>[:SELEcted]:BLIMit:FAIL?

(Write only) Get the result of activating track line bandwidth. Return 1 (TRUE) indicates bandwidth test success; Return 0 (FALSE) indicates bandwidth test failure. If the bandwidth test is not turned on, 0 (FALSE) is always read.

Parameter

<cnum> Channel number of measurement. This channel must have selected a measurement. If not specified, <cnum> is default to 1.

Example `CALC:BLIM:FAIL?`

Query Syntax CALCulate<cnum>:BLIMit:FAIL?

Return Type Bool (1 = TRUE, 0 = FALSE)

Overlapping? No

Default 0

CALCulate<cnum>[:SElected]:BLIMit:MAXimum <num>

(Read-Write) Set upper limit of bandwidth test

Parameter

<cnum> Channel number of measurement. This channel must have selected a measurement. If not specified, <cnum> is default to 1.

<num> Upper limit of bandwidth test 0 ~ 1e12 Hz

Example CALC:BLIM:MAX 1e6
 calculate2:selected:blimit:maximum 2e7

Query Syntax CALCulate<cnum>:BLIMit:MAXimum?

Return Type Char

Overlapping? No

Default 3e5

CALCulate<cnum>[:SElected]:BLIMit:MINimum <num>

(Read-Write) Set lower limit of bandwidth test.

Parameter

<cnum> Channel number of measurement. This channel must have selected a measurement. If not specified, <cnum> is default to 1.

<num> Lower limit of bandwidth test 0 ~ 1e12 Hz.

Example CALC:BLIM:MIN 3e5
 calculate2:selected:blimit:minimum 2e4

Query CALCulate<cnum>:BLIMit:MINimum?

Syntax

Return Type Char

Overlapping? No

Default 1e4

CALCulate<cnum>[:SELEcted]:BLIMit:REPort[:DATA]?

(Read-Write) Read bandwidth value of bandwidth test

Parameter

<cnum> Channel number of measurement. A measurement must be selected in the current channel. If not specified, <cnum> is default to 1.

Example `CALC:BLIM:REP?`

Query Syntax `CALCulate<cnum>:BLIMit:REPort:DATA?`

Return Type Char

Overlapping? No

Default NONE

CALCulate<cnum>[:SELEcted]:BLIMit[:STATe] <ON | OFF>

(Read-Write) Turn on or off bandwidth test function.

Parameter

<cnum> Channel number of measurement. This channel must have selected a measurement. If not specified, <cnum> is default to 1.

<ON | OFF> ON (or 1) - On.
OFF (or 0) - Off.

Example `CALC:BLIM ON`
`calculate2:selected:blimit:state off`

Query Syntax `CALCulate<cnum>:BLIMit[:STATe]?`

Return Type Bool (1 = ON, 0 = OFF)

Overlapping? No

Default OFF

Calc:CONVersion commands

Parameter conversion function.

Note: CALCulate command functions on the selected measurement. This channel must have selected a measurement. Use CALC:PAR:SEL command to select the measurement.

CALCulate<cnum>[:SELEcted]:CONVersion:FUNcTion <char>

(Read-Write) Set or inquire parameter type after conversion.

Parameter

<cnum> Channel number of measurement. This channel must have selected a measurement. If not specified, <cnum> is default to 1.

Parameter type after conversion.

ZREFlection - Equivalent impedance in reflection measurement

ZTRansmit - Equivalent impedance in transmission measurement (serial)

YREFlection - Equivalent admittance in reflection measurement

<char> YTRansmit - Equivalent admittance in transmission measurement (serial)

INVersion - Anti-S parameter

ZTSHunt - Equivalent impedance in transmission measurement (parallel)

YTSHunt - Equivalent admittance in transmission measurement (parallel)

CONJugation - Conjugation parameter

Example

```
CALC:SEL:CONV:FUNC ZTSH;
calculate2:Selected:conversion:function conj;
```

Query
Syntax

CALCulate<cnum>:CONVersion:FUNcTion?

Return Type Char

Overlapping? No

Default value ZREFlection

CALCulate<cnum>[:SELEcted]:CONVersion[:STATe] <ON | OFF>

(Read-Write) Turn on or off parameter conversion function.

Parameter

<cnum> Channel number of measurement. This channel must have selected a measurement. If not specified, <cnum> is default to 1.

<ON|OFF> ON (1) - On
OFF (0) - Off

Example

```
CALC:CONV ON
calculate2:selected:conversion:state off
```

Query Syntax

```
CALCulate<cnum>:CONVersion[:STATe]?
```

Return Type

```
Bool (1 = ON, 0 = OFF)
```

Overlapping? No

Default

OFF

Calc:Correction Command

Used to set electric delay and phase excursion.

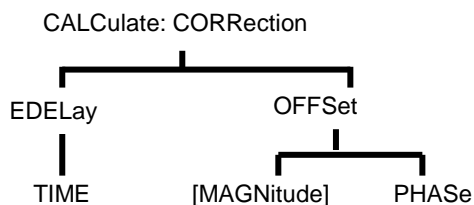

Note: CALCulate can function on the selected measurement. This channel must have selected a measurement. Use CALC<ChanNum>:PAR:SEL <MeasName> command to select a measurement.

CALCulate<cnum>:CORRection:EDELay:TIME <num>

(Read-Write) Set electric delay for the selected measurement.

Parameter

<cnum> Channel number of measurement. This channel must have selected a measurement. If not specified, <cnum> is default to 1.

<num> Electric delay, in the unit of s. Value range:

-10.00 - 10.00

Use SENS:CORR:RVEL:COAX <num> command to set velocity factor.

Example

```
CALC1:CORR:EDEL:TIME 1NS
calculate2:correction:time 0.5e-12
```

Query Syntax

```
CALCulate:CORRection:EDELay:TIME?
```

Return Type

Char

Overlapping? No

Default 0 second

CALCulate<num>:CORRection:Excursion[:MAGNitude] <num> (Not provided)

(Read-Write) Set the power level of receiver calibration for the selected measurement. This command is only effective on the selected non-ratio measurements.

Parameter

<num> Channel number of measurement. This channel must have selected a measurement. If not specified, <num> is default to 1.

<num> Power level. in the unit of dBm, The power level is not set with upper and lower limits, but the analyzer has its own maximum and minimum power index (determined by the specific instrument model), and therefore the power level must be within the range of the power calibration of the receiver.

Example

```
CALC:CORR:OFFS 0DBM
calculate1:correction:offset:magnitude maximum
```

Query Syntax

```
CALCulate<num>:CORRection:Excursion[:MAGNitude]?
```

Return Type Char

Overlapping? No

Default 0dBm

CALCulate<num>:CORRection:Excursion:PHASe <num>[<char>]

(Read-Write) Set phase excursion amount for the selected measurement.

Parameter

<num> Channel number of measurement. This channel must have selected a measurement. If not specified, <num> is default to 1.

<num> Phase excursion amount. Value range:
-360 - 360

<char> Phase unit: Options:
DEG - Degree (default)
RAD - Radian

Example

```
CALC:CORR:OFFS:PHAS 10
```

calculate:correction:offset:phase 20rad

Query Syntax CALCulate:CORRection:Excursion:PHASe?

Return Type Char, the returned value is always in units of degree.

Overlapping? No

Default 0 degree

Calc:Data Command

Send and receive the measurement data from analyzer.

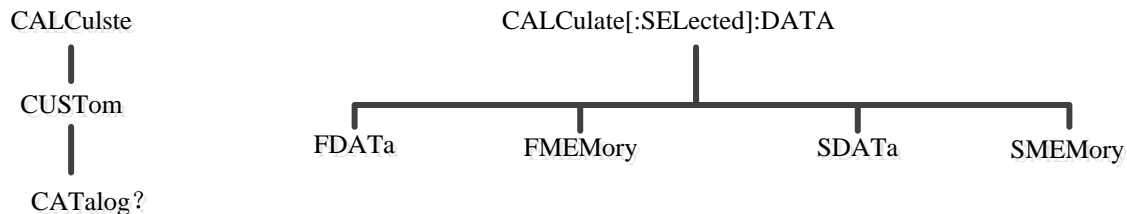

See Measurement Data Process Chart for storing and retrieving data.

CALCulate<num>:DATA <char>,<data>

Write: Measurement data, memory data, power correction factor data or error item.

CALCulate<num>:DATA? <char>

Read: Measurement data, memory data, power correction factor data or error item.

Returned measurement and data stored format:

REAL or ASCII (See [Transmission Measurement Data](#))

FDATA: each trace point has a data.

SDATA: each trace point has two data.

FMEM: each trace point has a data.

SMEM: each trace point has two data.

SDIV: each trace point has a data.

Returned error item format: each trace point has two data.

(See the below detailed description on error item <char>)

Parameter

<num> - Channel number of measurement. This channel must have selected a measurement. If not specified, <num> is default to 1.

<char> - Measurement data (DATA), memory data (MEM) or power correction factor data (DIV) to be read and write. Select:

FDATA - Formative data obtained from the position of measurement result.

SDATA - Corrected plural trace data obtained from the position of original measurement data.

FMEM - Formative memory data obtained from the position of memory result.

SMEM - Corrected plural data obtained from the position of save.

SDIV - Plural data obtained from the position of power correction factor.

Note: Power correction factor data is obtained form the power calibration of receiver.

<char> - Read and write error item...

Calibration of open circuit frequency response:

<char> is set to...	Error item obtained...
---------------------	------------------------

SCORR3	Reflected tracking
--------	--------------------

Calibration of short circuit frequency response:

<char> is set to...	Error item obtained...
---------------------	------------------------

SCORR3	Reflected tracking
--------	--------------------

Calibration of through frequency response:

<char> is set to...	Error item obtained...
---------------------	------------------------

SCORR6	Transmission tracking
--------	-----------------------

Calibration of through frequency response and isolation:

<char> is set to...	Error item obtained...
---------------------	------------------------

SCORR4	Isolation
--------	-----------

SCORR6	Transmission tracking
--------	-----------------------

Calibration of single port:

<char> is set to...	Error item obtained...
---------------------	------------------------

SCORR1	Directivity
--------	-------------

SCORR2	Source matching
--------	-----------------

SCORR3	Reflected tracking
--------	--------------------

Calibration of single port SOLT and TRL:

<char> is set to...	Error item obtained...
---------------------	------------------------

SCORR1	Forward Directivity
--------	---------------------

SCORR2	Forward Source matching
--------	-------------------------

SCORR3	Forward reflected tracking
--------	----------------------------

SCORR4	Forward isolation
--------	-------------------

SCORR5	Forward load matching
--------	-----------------------

SCORR6	Forward transmission tracking
--------	-------------------------------

SCORR7	Backward Directivity
--------	----------------------

SCORR8	Backward source matching
--------	--------------------------

SCORR9	Backward reflected tracking
--------	-----------------------------

SCORR10	Backward isolation
---------	--------------------

SCORR11	Backward load matching
SCORR12	Backward transmission tracking

Example: `CALC:DATA FDATA,Data(x)`
`calculate2:data sdata,data(r,i)`
 See other Example using this command.

Overlapping? No

Default NONE

Note: Before inquire the memory data, it must save the trace data to the memory using `CALC:MATH:MEMorize` command.

Before inquire the power correction factor data, it must save the power correction factor using `CALC:NORMalize[:IMMEDIATE]` command.

If the interpolation function of power calibration is turned on, and points are changed after initialization of power calibration, then power correction factor data will adopt interpolation data.

When accessing the error item, it must first ensure there are error items in analyzer.

If the interpolation function of calibration is turned on, and points are changed after initialization of power calibration, then the error items are the results obtained after interpolation.

To set and get the receiver data, see `CALC:RDATA?` command.

To get the unrevised ratio data, it is necessary to close the correction item and use `CALC:DATA SDATA` command.

`CALCulate` command is valid for the selected measurement. Each channel can select a measurement, thus 64 measurements at maximum simultaneously. It can use `CALC:PAR:SEL` command to choose a measurement for each channel.

CALCulate<cnum>:DATA:CUSTom <name>,<data> (Not provided)

(Read-Write) Read and write data from customized measurement buffer area. Use `CALCulate:PARAmeter:SElect` command to select the measurement.

Parameter

<cnum> Channel number of measurement. This channel must have selected a measurement. If not specified, <cnum> is default to 1.

<name> Name of buffer area to be read and written.

<data> Data to be read or written into the customized buffer area. Data format is one data for each measurement point.

Example `CALC:DATA:CUST 'VectorResult0',0,1,2,3,4,5 'Write`
`CALC:DATA:CUST? 'VectorResult0' 'Read`

Query Syntax `CALCulate:DATA:CUSTom? <name>`

Return Type REAL or ASCII (See Getting Data from the Analyzer)

Overlapping? No

Default NONE

CALCulate<cnum>:DATA:CUSTom:CATalog? (Not provided)

(Read only) Inquire the names of all buffer area in the specified channels (separated by commas). Use CALCulate:PARAmeter:SElect command to select the measurement.

Parameter

<cnum> Channel number of measurement. This channel must have selected a measurement. If not specified, <cnum> is default to 1.

Example

```
CALC:DATA:CUST:CAT?
calculate:data:custom:catalog?
```

Return Type REAL or ASCII (see Getting Data from the Analyzer)

Overlapping? No

Default NONE

CALCulate<cnum>[:SElected]:DATA::FDATa <data>

(Read-Write) Set/get the formative data array for the active traces in the current channels (cnum).

Parameter

<cnum> Channel number of measurement. This channel must have selected a measurement. If not specified, <cnum> is default to 1.

<data> Data format a1,b1,a2,b2,...,aN,bN
N: number of measurement points
an: principal value of the nth measurement point
bn: sub-value of the nth measurement point

Example

```
CALC:DATA:FDAT 3.1,1.2e-2,2.5,1.0e-2,0.9,2e-2,1.21,2.1e-2...
calculate:selected:data:fdata?
```

Return Type REAL or ASCII (see Getting Data from the Analyzer)

Overlapping? No

Default NONE

CALCulate<cnum>[:SElected]:DATA::FMEMory <data>

(Read-Write) Set/get the formative memory data array for the active traces in the current channels (cnum).

Parameter

<cnum> Channel number of measurement. This channel must have selected a measurement. If not specified, <cnum> is default to 1.

<data> Data format a1,b1,a2,b2,...,aN,bN
N: number of measurement point
an: principal value of the nth measurement point
bn: sub-value of the nth measurement point

Example

```
CALC:DATA:FMEM 0.002,0,0.123,0,1.234,0,2.145,0,0.78,0...
calculate:selected:data:fmemory?
```

Return Type REAL or ASCII (see Getting Data from the Analyzer)

Overlapping? No

Default NONE

CALCulate<cnum>[:SElected]:DATA::SDATa <data>

(Read-Write) Set/get the correction data array for the active traces in the current channels (cnum).

Parameter

<cnum> Channel number of measurement. This channel must have selected a measurement. If not specified, <cnum> is default to 1.

<data> Data format a1,b1,a2,b2,...,aN,bN
N: number of measurement point
an: real part of the nth measurement point data
bn: imaginary part of the nth measurement point data

Example

```
CALC:DATA:SDAT 0.78,2.19e-2,0.65,7.17e-2,0.28,8.2e-1,0.92,3.8e-2...
calculate:selected:data:sdata?
```

Return Type REAL or ASCII (see Getting Data from the Analyzer)

Overlapping? No

Default NONE

CALCulate<cnum>[:SElected]:DATA::SMEMory <data>

(Read-Write) Set/get the correction memory data array for the active traces in the current channels

(cnum).

Parameter

<cnum> Channel number of measurement. This channel must have selected a measurement. If not specified, <cnum> is default to 1.

<data> Data format a1,b1,a2,b2,...,aN,bN
N: number of measurement point
an: real part of the nth measurement point data
bn: imaginary part of the nth measurement point data

Example

```
CALC:DATA:SMEM 23,0.12,45,0.28,37,0.77...
calculate:selected:data:smemory?
```

Return Type REAL or ASCII (see Getting Data from the Analyzer)

Overlapping? No

Default NONE

Calc:Filter Command

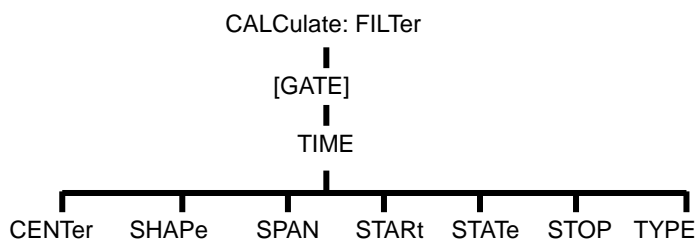

Door function command for time domain measurement. Gate range is set by the start/stop or center/span command.

Note: CALCulate command functions on the selected measurement. This channel must have selected a measurement. Use CALC:PAR:SEL command to select the measurement.

CALCulate<cnum>:FILTer[:GATE]:TIME:CENTer <num>

(Read-Write) Set the center time of gate.

Parameter

<cnum> Channel number of measurement. This channel must have selected a measurement. If not specified, <cnum> is default to 1.

<num> Center time, in seconds. Value range:
 $\pm(\text{point}-1) / \text{frequency span}$
 Note: This command receives MIN and MAX parameters. See SCPI Syntax for detail.

Example `CALC:FILT:GATE:TIME:CENT -5ns calculate2:filter:time:center maximum`

Query Syntax `CALCulate<cnum>:FILTer[:GATE]:TIME:CENTer?`

Return Type Char

Overlapping? No

Default 0

CALCulate<cnum>:FILTer[:GATE]:TIME:SHAPE <char>

(Read-Write) Set the gate shape of time domain measurement.

Parameter

<cnum> Channel number of measurement. This channel must have selected a measurement. If not specified, <cnum> is default to 1.

Select:

MAXimum - Maximum

<char> WIDE - Wide

NORMal - Standard

MINimum - Minimum

Example `CALC:FILT:GATE:TIME:SHAP MAX calculate2:filter:time:shape normal`

Query Syntax `CALCulate<cnum>:FILTer[:GATE]:TIME:SHAPE?`

Return Type Char

Overlapping? No

Default NORMal

CALCulate<cnum>:FILTer[:GATE]:TIME:SPAN <num>

(Read-Write) Set the time span of gate.

Parameter

<cnum> Channel number of measurement. This channel must have selected a measurement. If not specified, <cnum> is default to 1.

Time span, in seconds. Value range:

<num> $0 \sim 2^{*} \square [(point-1) / span]$

Note: This command receives MIN and MAX parameters. See SCPI Syntax for detail.

Example `CALC:FILT:GATE:TIME:SPAN 5ns calculate2:filter:time:span maximum`

Query Syntax `CALCulate<cnum>:FILTer[:GATE]:TIME:SPAN?`

Return Type Char

Overlapping? No

Default 20ns

CALCulate<cnum>:FILTer[:GATE]:TIME:STATe <boolean>

(Read-Write) Turn on or off gate function.

Note: When using gate function, the sweep type should be set to linear frequency.

Parameter

<cnum> Channel number of measurement. This channel must have selected a measurement. If not specified, <cnum> is default to 1.

<boolean> ON (or 1) - On.
OFF (or 0) - Off.

Example `CALC:FILT:TIME:STAT ON calculate2:filter:gate:time:state off`

Query Syntax `CALCulate<cnum>:FILTer[:GATE]:TIME:STATe?`

Return Type Bool (1 = ON, 0 = OFF)

Overlapping? No

Default NONE

CALCulate<cnum>:FILTer[:GATE]:TIME:STARt <num>

(Read-Write) Set the start time of gate.

Parameter

<cnum> Channel number of measurement. This channel must have selected a measurement. If not specified, <cnum> is default to 1.

<num> Start time, in seconds. Value range:
 $\pm(\text{point}-1)/\text{frequency span}$
Note: This command receives MIN and MAX parameters. See SCPI Syntax for detail.

Example **CALC:FILT:TIME:STAR 1e-8**
 calculate2:filter:gate:time:start minimum

Query Syntax CALCulate<cnum>:FILTer[:GATE]:TIME:STARt?

Return Type Char

Overlapping? No

Default 10ns

CALCulate<cnum>:FILTer[:GATE]:TIME:STOP <num>

(Read-Write) Set the stop time of gate.

Parameter

<cnum> Channel number of measurement. This channel must have selected a measurement. If not specified, <cnum> is default to 1.

<num> Stop time, in seconds. Value range:
 $\pm(\text{point}-1)/\text{frequency span}$
 Note: This command receives MIN and MAX parameters. See SCPI Syntax for detail.

Example **CALC:FILT:TIME:STOP -1ns**
 calculate2:filter:gate:time:stop maximum

Query Syntax CALCulate<cnum>:FILTer[:GATE]:TIME:STOP?

Return Type Char

Overlapping? No

Default 10ns

CALCulate<cnum>:FILTer[:GATE]:TIME[:TYPE] <char>

(Read-Write) Set gate type.

Parameter

<cnum> Channel number of measurement. This channel must have selected a measurement. If not specified, <cnum> is default to 1.

<char> Select:
 BPASs - Band pass
 NOTCh - Band elimination

Example `CALC:FILT:TIME BPAS calculate2:filter:gate:time:type notch`

Query Syntax `CALCulate<cnum>:FILTer[:GATE]:TIME[:TYPE]?`

Return Type Char

Overlapping? No

Default BPAS

Calc:Format Command

Note: CALCulate command functions on the selected measurement. There may be a selected measurement for each channel. Use CALC:PAR:SEL command to select a measurement.

CALCulate<cnum>:FORMat <char>

(Read-Write) Set the display format of measurement.

Parameter

<cnum> Channel number of measurement. There must be a selected measurement in that channel. If unspecified, <cnum> is default to 1.

Display format. Options:
 MLINear (Linear amplitude)
 MLOGarithmic (Logarithm magnitude)
 PHASe (Phase)
 IMAGinary (Imaginary part)
 REAL (Real part)
 POLar (Polar Coordinates)
 SMITH (Smith chart)
 SWR (Standing-wave Ratio)
 GDElay (Group delay)

<char>

Example `CALC:FORM MLIN
calculate2:format polar`

Query Syntax `CALCulate<cnum>:FORMat?`

Return Type Char

Overlapping? No

Default MLINear

Calc:Function Commands

Perform search, analysis and statistics of trace data.

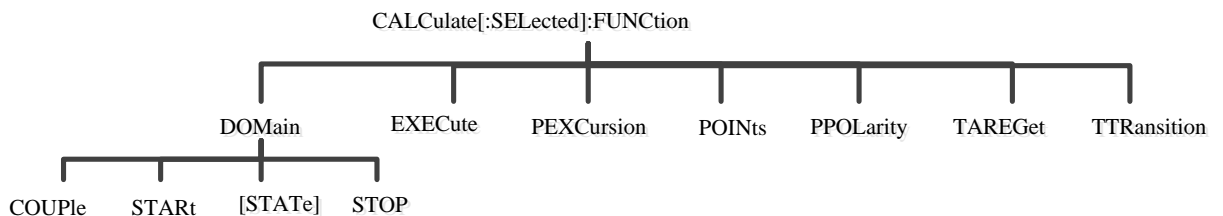
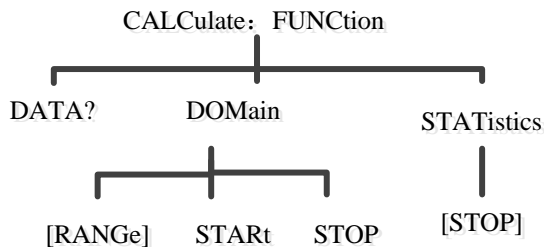

Note: CALCulate command functions on the selected measurement. This channel must have selected a measurement. Use CALC:PAR:SEL command to select the measurement.

CALCulate<cnum>:FUNCTION:DATA?

(Read only) Return the statistics data of the specified statistics type on the specified channel. Use CALC:FUNC:TYPE command to select statistics type.

Parameter

<cnum> Channel number of measurement. This channel must have selected a measurement. If not specified, <cnum> is default to 1.

Return Type Char

Example `CALCulate2:FUNCTION:DATA?`

Overlapping? No

Default NONE

CALCulate<cnum>:FUNCTION:DOMain:USER[:RANGe] <range>

(Read-Write) Set the user filed during trace statistics. Each channel shares 10 fields. Use CALC:FUNC:DOM:USER:START and STOP commands to define the user field range.

Parameter

<cnum>	Channel number of measurement. This channel must have selected a measurement. If not specified, <cnum> is default to 1.
<range>	User filed. Value range: 0 to 9. 0: full bandwidth (X-axis range at current). 1 - 9: self-defining user field.

Example `CALC:FUNC:DOM:USER 4 calculate2:function:domain:user:range 0`

Query Syntax `CALCulate<cnum>:FUNCTION:DOMain:USER[:RANGE]?`

Return Type Char

Overlapping? No

Default 0 - Full bandwidth

CALCulate<cnum>:FUNCTION:DOMain:USER:STARt <range>, <start>

(Read-Write) Set the start value of the specified user filed.

It can use `CALC:FUNC:DOM:USER` command to select the user filed to use this range.

It can use `CALC:FUNC:DOM:USER:STOP` command to set the end value of user filed.

Note: This command shares the same function with `CALC:MARK:FUNC:DOM:USER:STAR` command.

Parameter

<cnum>	Channel number of measurement. This channel must have selected a measurement. If not specified, <cnum> is default to 1.
<range>	User filed. Value range: 1 to 9.
<start>	Set the start value of the specified user filed. Value range: real number between MIN and MAX of analyzer X-axis.

Example `CALC:FUNC:DOM:USER:STAR 1,1e9 calculate2:function:domain:user:start 2,2e9`

Query Syntax `CALCulate<cnum>:FUNCTION:DOMain:USER:STARt? <range>`

Return Type Char

Overlapping? No

Default MIN of analyzer X-axis.

CALCulate<cnum>:FUNCTION:DOMain:USER:STOP <range>, <stop>

(Read-Write) Set the end value of the specified user filed.

It can use CALC:FUNC:DOM:USER command to select the user filed to use this range.

It can use CALC:FUNC:DOM:USER:START command to set the start value of user field.

Note: This command shares the same function with CALC:MARK:FUNC:DOM:USER:STOP command.

Parameter

<num>	Channel number of measurement. This channel must have selected a measurement. If not specified, <num> is default to 1.
<range>	User filed. Value range: 1 to 9.
<stop>	Set the end value of the specified user filed. Value range: real number between MIN and MAX of analyzer X-axis.

Parameter CALC:FUNC:DOM:USER:STOP 4,5e9 calculate2:function:domain:user:stop 3,8e9

Query Syntax CALCulate<num>:FUNCtion:DOMain:USER:STOP? <range>

Return Type Char

Overlapping? No

Default MAX of analyzer X-axis.

CALCulate<num>:FUNCtion:STATistics[:STATe] <ON|OFF>

(Read-Write) Display or hide trace statistics data on the screen (peak-to-peak value, average value and standard deviation).

Parameter

<num>	Channel number of measurement. This channel must have selected a measurement. If not specified, <num> is default to 1.
<ON OFF>	ON - Display trace statistics OFF - Hide trace statistics

Example CALC:FUNC:STAT ON calculate2:function:statistics:state off

Query Syntax CALCulate<num>:FUNCtion:STATistics[:STATe]?

Return Type Bool (1 = ON, 0 = OFF)

Overlapping? No

Default OFF (0)

CALCulate<num>:FUNCTION:TYPE <char>

(Read-Write) Set or inquire analysis type.

Parameter

<num> Channel number of measurement. This channel must have selected a measurement. If not specified, <num> is default to 1.

Select:

PTPeak - Peak-to-peak value

STDEV - Standard deviation

MEAN - Average value

<char> **MAXimum** - Max value

MINimum - Min value

PEAK - Peak value

APEak - All peak value

ATARget - All target value

Example

```
CALC:FUNC:TYPE PTP calculate2:function:type stdev
```

Query
Syntax

```
CALCulate<num>:FUNCTION:TYPE?
```

Return Type Char

Overlapping? No

Default PTPeak

CALCulate<num>[:SELEcted]:FUNCTION:DOMain:COUPlE <ON|OFF>

(Read-Write) Set/get the trace coupling status of analysis range on the specified channel.

Note: When the coupling is on, it sets CALC:FUNC:EXECute analysis range for all traces in the channel. otherwise, only for active traces.

Parameter

<num> Channel number of measurement. This channel must have selected a measurement. If not specified, <num> is default to 1.

<ON|OFF> ON - Turn on analysis range coupling

OFF - Turn off analysis range coupling

Example

```
CALC:FUNC:DOM:COUP ON
calculate2:selected:function:domain:couple off
```

Query
Syntax

```
CALCulate<num>:SELEcted:FUNCTION:DOMain:COUPlE?
```

Return Type Bool (1 = ON, 0 = OFF)

Overlapping? No

Default ON

CALCulate<cnum>[:SELEcted]:FUNction:DOMain:STARt <num>

(Read-Write) Set/get the start value of analysis range.

Parameter

<cnum> Channel number of measurement. This channel must have selected a measurement. If not specified, <cnum> is default to 1.

<num> Start value of analysis range (Hz, dBm or s).

Example

```
CALC:FUNC:DOM:STAR 1e9
calculate:selected:function:domain:start 5E8
```

Query Syntax

CALCulate<cnum>:SELEcted:FUNction:DOMain:STARt?

Return Type Char

Overlapping? No

Default 0

CALCulate<cnum>[:SELEcted]:FUNction:DOMain[:STATe] <ON|OFF>

(Read-Write) Turn on/off the analysis range on the specified channel. If turn off analysis range, the analysis will function on the whole sweep range.

Parameter

<cnum> Channel number of measurement. This channel must have selected a measurement. If not specified, <cnum> is default to 1.

<ON|OFF> ON - Turn on analysis range
OFF - Turn off analysis range

Example

```
CALC:FUNC:DOM ON
calculate2:selected:function:domain:state off
```

Query Syntax CALCulate<cnum>:SELEcted:FUNction:DOMain:STATe?

Return Type Bool (1 = ON, 0 = OFF)

Overlapping? No

Default OFF

CALCulate<cnum>[:SELEcted]:FUNCtion:DOMain:STOP <num>

(Read-Write) Set/get the end value of analysis range on the specified channel.

Parameter

<cnum> Channel number of measurement. This channel must have selected a measurement. If not specified, <cnum> is default to 1.

<num> End value of analysis range (Hz, dBm or s).

Example

```
CALC:FUNC:DOM:STOP 2e9
calculate2:selected:function:domain:stop 2000000
```

Query
Syntax

```
CALCulate<cnum>:SELEcted:FUNCtion:DOMain:STOP?
```

Return Type Char

Overlapping? No

Default 0

CALCulate<cnum>[:SELEcted]:FUNCtion:EXECute

(Write only) Perform the analysis function on the active traces in the selected channel (cnum). This analysis type is specified by CALCulate:FUNCtion:TYPE.

Note: It must first perform this command before reading analysis data (CALC:FUNC:DATA?), otherwise the obtained data is the last analysis result or 0 (NULL).

Parameter

<cnum> Channel number of measurement. This channel must have selected a measurement. If not specified, <cnum> is default to 1.

Example

```
CALC:FUNC:EXEC
calculate2:selected:function:execute
```

Overlapping? No

Default NONE

CALCulate<cnum>[:SELEcted]:FUNCtion:PEXCursion <num>

(Read-Write) Set/get the peak excursion value when searching the peak value (analysis type is PEAK or APEak).

Note: When the coupling is on, it sets CALC:FUNC:EXECute analysis range for all traces in the channel. otherwise, only for active traces.

Parameter

<cnum> Channel number of measurement. This channel must have selected a measurement. If not specified, <cnum> is default to 1.

<num> Peak excursion value. Value range: -500 to 500

Example

```
CALC:FUNC:PEXCursion 0.2
calculate2:selected:function:pexcursion 1.5
```

Query Syntax

CALCulate<cnum>:SELEcted:FUNcTion:PEXCursion?

Return Type Char

Overlapping? No

Default 3

CALCulate<cnum>[:SELEcted]:FUNcTion:POINts?

(Read only) Get the data pair number of analysis result.

Only when searching all peak value or target value, data pair number of larger than 1 can be obtained.

Parameter

<cnum> Channel number of measurement. This channel must have selected a measurement. If not specified, <cnum> is default to 1.

Example

```
CALC:FUNC:POINts?
```

Query Syntax

CALCulate<cnum>:SELEcted:FUNcTion:POINts?

Return Type Char

Overlapping? No

Default NONE

CALCulate<cnum>[:SELEcted]:FUNcTion:PPOLarity <char>

(Read-Write) Set/get the peak polarity analyzed on the specified channel when searching the peak value (analysis type is PEAK or APEak).

Parameter

<num>	Channel number of measurement. This channel must have selected a measurement. If not specified, <num> is default to 1.
<char>	POSitive - Positive peak value NEGative - Negative peak value BOTH - Positive and negative peak value

Example

```
CALC:FUNC:PPOL BOTH
calculate2:selected:function:ppolarity negative
```

Query Syntax

```
CALCulate<num>:SELEcted:FUNcTion:PPOLarity?
```

Return Type Char(POSitive/NEGative/BOTH)

Overlapping? No

Default POSitive

CALCulate<num>[:SELEcted]:FUNcTion:TARGet <num>

(Read-Write) Set/get the target value analyzed on the specified channel when searching the target (analysis type is ATARget).

Parameter

<num>	Channel number of measurement. This channel must have selected a measurement. If not specified, <num> is default to 1.
<num>	Target value.

Example

```
CALC:FUNC:TARG 1.5
calculate2:selected:function:target -3.0
```

Query Syntax

```
CALCulate<num>:SELEcted:FUNcTion:TARGet?
```

Return Type Char

Overlapping? No

Default 0

CALCulate<num>[:SELEcted]:FUNcTion:TTRansition <char>

(Read-Write) Set/get the target value transition type of analysis on the specified channel when searching

the target (analysis type is ATARget).

Parameter

<num> Channel number of measurement. This channel must have selected a measurement. If not specified, <num> is default to 1.

<char> POSitive - Specify positive transition
 NEGative - Specify negative transition
 BOTH - Specify positive and negative transition

Example

CALC:FUNC:TTR POS
 calculate2:selected:function:ttransition both

Query Syntax CALCulate<num>:SELEcted:FUNcTion:TTRansition?

Return Type Char (POSitive/NEGative/BOTH)

Overlapping? No

Default BOTH

Calc:Limit Commands

Limit line setting during limit test.

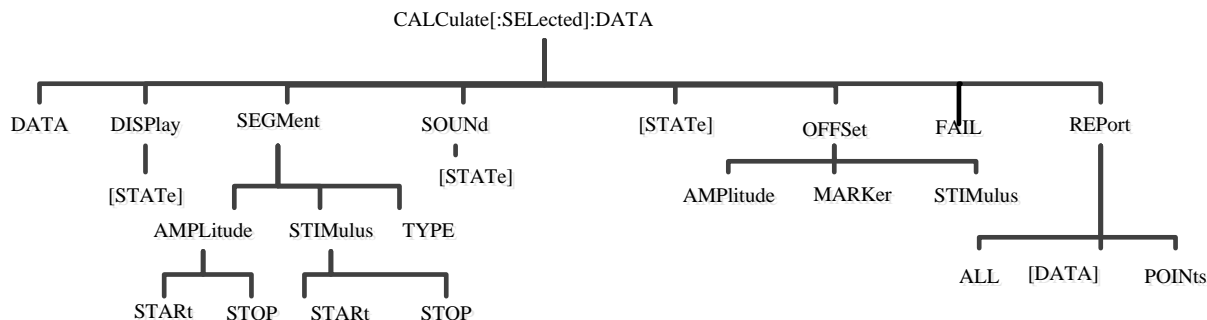

Note: CALCulate command functions on the selected measurement. This channel must have selected a measurement. Use CALC:PAR:SEL command to select a measurement.

CALCulate<num>:LIMit:DATA <block>

(Read-Write) Set or inquire limit segment data.

Parameter

<num> Channel number of measurement. This channel must have selected a measurement. If not specified, <num> is default to 1.

<block> The data for each segment in the limit list is in 64-bit real number format. The following is an example of the data for a limit segment in the limit table:

Type,BegStim, EndStim, BegResp,EndResp

Type Limit segment type:
 0 - Off
 1 - Max
 2 - Min

BegStim Beginning stimulus. (Beginning value of X-axis (frequency, power, time)).

EndStim End stimulus. (End value of the X-axis).

BegResp Beginning response. (Value of Y-axis corresponding to the beginning value of X-axis).

EndResp End response. (Value of Y-axis corresponding to the end value of X-axis).

Example

```
Setting three upper limit segments for the bandpass filter:
"CALC:LIM:DATA 1,3e5,4e9,-60,0,1,4e9,7.5e9,0,0,1,7.5e9,9e9,0,-30"
```

Query
Syntax

CALCulate<cnum>:LIMit:DATA?

Return Type Fixed-length data block - Return data of 100 predefined limit segments.

Overlapping? No

Default 100 limit segments - All values are set to 0.

CALCulate<cnum>:LIMit:DISPlay[:STATe] <ON | OFF>

(Read-Write) Display or hide limit table (with trace).

Parameter

<cnum> Channel number of measurement. This channel must have selected a measurement. If not specified, <cnum> is default to 1.

<ON | OFF> ON (or 1) - Display the limit table.
 OFF (or 0) - Hide the limit table.

Example

```
CALC:LIM:DISP:STAT ON
calculate2:limit:display:state off
```

Query
Syntax

CALCulate<cnum>:LIMit:DISPlay[:STATe]?

Return Type Bool(1 = ON, 0 = OFF)

Overlapping? No

Default OFF

CALCulate<num>:LIMit:SEGment<num>AMPLitude:STARt <num>

(Read-Write) Set the start value of the response of Y-axis.

Parameter

<num> Channel number of measurement. This channel must have selected a measurement. If not specified, <num> is default to 1.

<num> Limit segment number. If unspecified, set to 1.

<num> Beginning response value. Value range:
-500 - 500
Display value between max value and min value of Y-axis.

Example

```
CALC:LIM:SEGM1:AMPL:STAR 10
calculate2:limit:segment2:amplitude:start 10
```

Query
Syntax

CALCulate<num>:LIMit:SEGment<num>AMPLitude:STARt?

Return Type Char

Overlapping? No

Default 0

CALCulate<num>:LIMit:SEGment<num>AMPLitude:STOP <num>

(Read-Write) Set the stop time of the response of Y-axis.

Parameter

<num> Channel number of measurement. This channel must have selected a measurement. If not specified, <num> is default to 1.

<num> Limit segment number. If unspecified, set to 1.

<num> End response value. Value range:
-500 - 500
Display value between max value and min value of Y-axis.

Example

```
CALC:LIM:SEGM1:AMPL:STOP 10
calculate2:limit:segment2:amplitude:stop 10
```

Query

CALCulate<num>:LIMit:SEGment<num>AMPLitude:STOP?

Syntax

Return Type Char

Overlapping? No

Default 0

CALCulate<cnum>:LIMit:SEGMENT<snum>STIMulus:STARt <num>

(Read-Write) Set the start value of the X-axis stimulus of the limit segment.

Parameter

<cnum> Channel number of measurement. This channel must have selected a measurement. If not specified, <cnum> is default to 1.

<snum> Limit segment number. If unspecified, set to 1.

<num> Beginning stimulus. Any value within the span of the analyzer's X-axis.

Example

```
CALC:LIM:SEGM1:STIM:STAR 10
calculate2:limit:segment2:stimulus:start 10
```

Query
Syntax

CALCulate<cnum>:LIMit:SEGMENT<snum>STIMulus:STARt?

Return Type Char

Overlapping? No

Default 0

CALCulate<cnum>:LIMit:SEGMENT<snum>STIMulus:STOP <num>

(Read-Write) Set the end value of X-axis stimulus of the limit segment.

Parameter

<cnum> Channel number of measurement. This channel must have selected a measurement. If not specified, <cnum> is default to 1.

<snum> Limit segment number. If unspecified, set to 1.

<num> End stimulus. Any value within the span of the analyzer's X-axis.

Example

```
CALC:LIM:SEGM1:AMPL:STOP 10
calculate2:limit:segment2:stimulus:stop 10
```

Query Syntax CALCulate<cnum>:LIMit:SEGMENT<snum>STIMulus:STOP?

Return Type Char

Overlapping? No

Default 0

CALCulate<cnum>:LIMit:SEGMENT<snum>:TYPE <char>

(Read-Write) Set limit segment type.

Parameter

<cnum> Channel number of measurement. This channel must have selected a measurement. If not specified, <cnum> is default to 1.

<snum> Limit segment number. Value range:
1 - 100
if unspecified, default to 1.

<char> Limit segment type. Select:
LMAX - Maximun limit segment. Connect a line between the start response and the end response in this segment, and any data above this line will cause failure of the limit test.
LMIN - Minimum limit segment. Connect a line between the start response and the end response in this segment, and any data below this line will cause failure of the limit test.
OFF (or 0) - Turn off limit segment.

Example

```
CALC:LIM:SEGM:TYPE LMIN
calculate2:limit:segment3:type lmax
```

Query Syntax CALCulate<cnum>:LIMit:SEGMENT<snum>:TYPE?

Return Type Char

Overlapping? No

Default OFF

CALCulate<cnum>[:SELEcted]:LIMit:FAIL?

(Read only) Read the result of the limit test.

If the reading is TRUE, the limit test fails (FAIL); and if the reading is FALSE, the limit test is successful (PASS).

Note: The reading is already FALSE When the limit test is turned off.

Parameter

<cnum> Channel number of measurement. This channel must have selected a measurement. If not specified, <cnum> is default to 1.

Example `CALC:LIM:FAIL?`

Query Syntax `CALCulate<cnum>:SElected:LIMit:FAIL?`

Return Type Bool (TRUE, FALSE)

Overlapping? No

Default NONE

CALCulate<cnum>[:SElected]:LIMit:OFFSet:AMPLitude <num>

(Read-Write) Set or read the amplitude offset of the limit line. This command is valid for the selected measurement.

Parameter

<cnum> Channel number of measurement. If not specified, <cnum> is default to 1.

<num> Amplitude offset value. (-1e5 ~ 1e5)

Example `CALC:LIM:OFFS:AMPL 0.3`
`calculate2:selected:limit:offset:amplitude 1`

Query Syntax `CALCulate<cnum>:LIMit:OFFSet:AMPLitude?`

Return Type Char

Overlapping? No

Default 0

CALCulate<cnum>[:SElected]:LIMit:OFFSet:MARKer

(Read only) Set the amplitude offset of the limit line to the amplitude value of the current active marker.
 Note: This command cannot be run when the marker is not displayed.

Parameter

<cnum> Channel number of measurement. This channel must have selected a measurement. If not specified, <cnum> is default to 1.

Example `Calculate2:Selected:Limit:Offset:Marker`

Overlapping? No

Default NONE

CALCulate<cnum>[:SELEcted]:LIMit:OFFSet:STIMulus <num>

(Read-Write) Set or read the stimulus offset of the limit line. This command is valid for the selected measurement.

Parameter

<cnum> Channel number of measurement. If not specified, <cnum> is default to 1.

<num> Stimulus offset value. (-1e12 ~ 1e12)

Example `CALC:LIM:OFFS:STIM 3e5`
`calculate2:selected:limit:offset:stimulus 3e5`

Query Syntax `CALCulate<cnum>:LIMit:OFFSet:STIMulus?`

Return Type Char

Overlapping? No

Default 0

CALCulate<cnum>[:SELEcted]:LIMit:REPort:ALL?

(Read only) Read the limit test results (including stimulus value, test result, upper limit value and lower limit value) of all measurement points

The returned data is of block data type (see Data type). A total of N groups of data (N is equal to the current number of sweep points) are recorded, and group consists of 4 parts:

- stimulus - Stimulus value
- result - Result of limit test. 0: Failure 1: Success -1: No limit
- ceiling - Upper limit (0 when no upper limit)
- floor - Lower limit (0 when no lower limit)

Parameter

<cnum> Channel number of measurement. This channel must have selected a measurement. If not specified, <cnum> is default to 1.

Example `CALC:SEL:LIM:REP:ALL?`

Query `CALCulate<cnum>:LIMit:REPort:ALL?`

Syntax

Return Type Block

CALCulate<cnum>[:SELEcted]:LIMit:REPort[:DATA]?

(Read only) Read the stimulus values of all failure points in the limit test .

The returned data is of block data type (see Data type) and contains N stimulus values. N is equal to the number of failure points in the limit test (may be read by CALCulate:SELEcted:LIMit:REPort:POINts?).

Parameter

<cnum> Channel number of measurement. This channel must have selected a measurement. If not specified, <cnum> is default to 1.

Example `CALC:SEL:LIM:REP:DATA?`

Query Syntax `CALCulate<cnum>:SELEcted:LIMit:REPort:DATA?`

Return Type Block

Overlapping? No

Default NONE

CALCulate<cnum>[:SELEcted]:LIMit:REPort:POINts?

(Read only) Read the number of failure points in the limit test.

Parameter

<cnum> Channel number of measurement. This channel must have selected a measurement. If not specified, <cnum> is default to 1.

Example `CALC:SEL:LIM:REP:POIN?`
`calculate2:selected:limit:report:points?`

Query Syntax `CALCulate<cnum>:LIMit:REPort:POINts?`

Return Type Char

Overlapping? No

Default NONE

CALCulate<cnum>:LIMit:SOUNd[:STATe] <ON | OFF>

(Read-Write) Turn on or off the sound prompt of limit test.

Parameter

<num> Channel number of measurement. This channel must have selected a measurement. If not specified, <num> is default to 1.

<ON | OFF> ON (or 1) - On.
OFF (or 0) - Off.

Example

```
CALC:LIM:SOUN ON
calculate2:limit:sound:state off
```

Query
Syntax

CALCulate<num>:LIMit:SOUNd[:STATe]?

Return Type Bool (1 = ON, 0 = OFF)

Overlapping? No

Default OFF

CALCulate<num>:LIMit:STATe <ON | OFF>

(Read-Write) Turn on or off limit test.

Use CALC:LIM:DISP command to display or hide limit table.

Parameter

<num> Channel number of measurement. This channel must have selected a measurement. If not specified, <num> is default to 1.

<ON | OFF> ON (or 1) - On.
OFF (or 0) - Off.

Example

```
CALC:LIM:STAT ON
calculate2:limit:state off
```

Query
Syntax

CALCulate<num>:LIMit:STATe?

Return Type Bool (1 = ON, 0 = OFF)

Overlapping? No

Default OFF

Calc:Marker Commands

Marker setting commands for programmed output of related data.

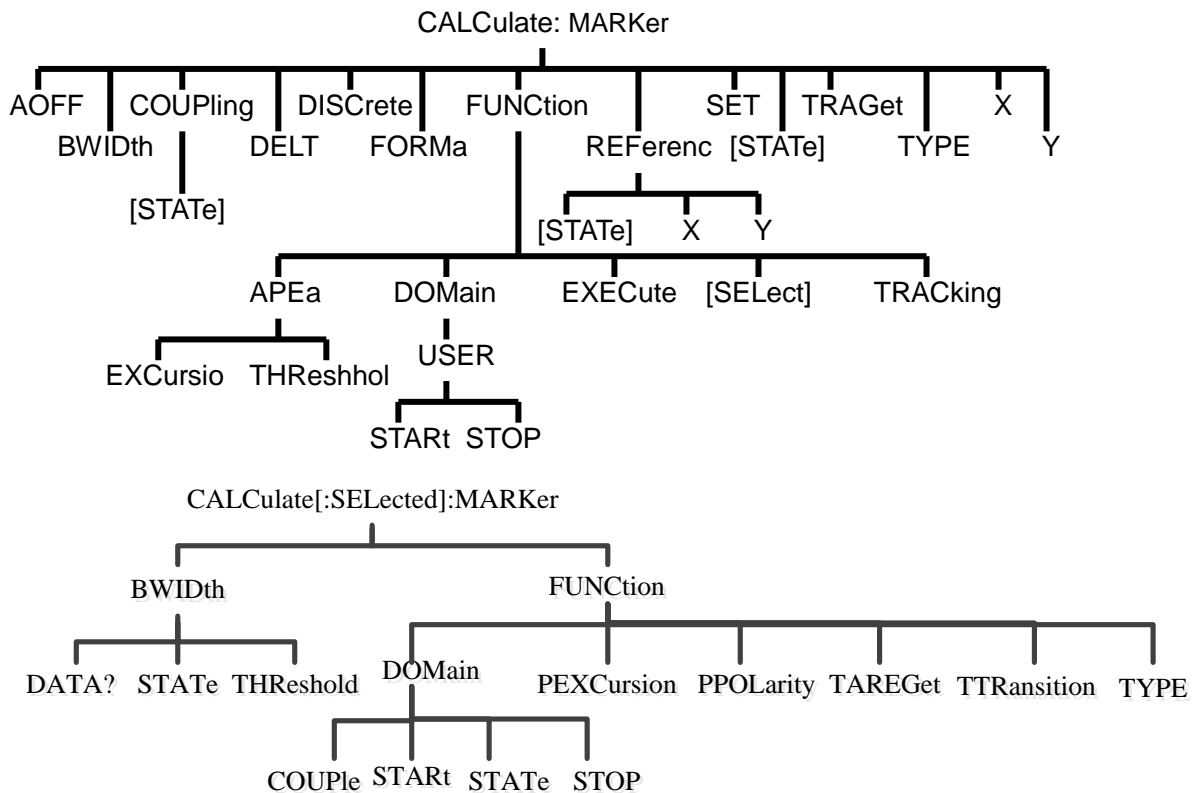

Commands to view the number of markers displayed on the window and the font size of the marker.

Note: CALCulate command functions on the selected measurement. There may be a selected measurement for each channel. Use CALC:PAR:SEL command to select the measurement.

Note: The reference marker is marker 10.

CALCulate<cnm>:MARKer:AOFF

(Read only) Turn off all markers for the selected measurement.

Parameter

<cnm> Channel number of measurement. This channel must have selected a measurement. If not specified, <cnm> is default to 1.

Example

```
CALC:MARK:AOFF
calculate2:marker:aoff
```

Query Syntax NONE

Overlapping? No

Default NONE

CALCulate<cnum>:MARKer:BWIDth <num>

(Read-Write) Activate markers 1 to 4 to calculate the filter bandwidth. <num> is the bandwidth of the filter to be calculated. For example, if the bandwidth measured is 3dB, set <num> to -3. Use the Close All marker command to close all markers or individual markers.

To search within the user domain using “Bandwidth Search”, first you need to activate marker 1 and set the desired user domain. Then send the CALC:MARK:BWID command.

Parameter

<cnum>	Channel number of measurement. This channel must have selected a measurement. If not specified, <cnum> is default to 1.
<num>	Lower than the target value of the filter peak. Value range: -500 to 500

Example

```
CALC:MARK:BWID -3
calculate2:marker:bwid -2.513
```

Query
Syntax

CALCulate<cnum>:MARKer:BWIDth?
Return to the bandwidth value searched

Return Type Strings separated by commas (','): bandwidth, center frequency, quality factor Q and loss.

Overlapping? No

Default -3

CALCulate<cnum>:MARKer<mkr>:COUPling[:STATe]<ON|OFF> (Not supported)

(Read-Write) Set or read the status of the coupled marker (on or off).

Parameter

<cnum>	Channel number of measurement. This channel must have selected a measurement. If not specified, <cnum> is default to 1.
<mkr>	Marker number. Range: 1 or -10; if unspecified, default to marker 1.
<ON OFF>	False (0) - Turn off coupled marker. True (1) - Turn on coupled marker.

Example

```
CALC:MARK:COUP ON
calculate2:marker8:coupling off
```

Query
Syntax

CALCulate<cnum>:MARKer<mkr>:COUPling[:STATe]?

Return Type Bool (1 = ON, 0 = OFF)

Overlapping? No

Default OFF

CALCulate<cnum>:MARKer<mkr>:DELTA <ON|OFF>

(Read-Write) Set the marker to be a Δ marker or an absolute marker relative to the reference marker.

Parameter

<cnum> Channel number of measurement. This channel must have selected a measurement. If not specified, <cnum> is default to 1.

<mkr> Marker number. Range 1 - 10; if unspecified, default to marker 1.

<ON|OFF> ON (or 1) - Δ marker.
OFF (or 0) - Absolute marker.

Example

```
CALC:MARK:DELTA ON
calculate2:marker8:delta off
```

Query Syntax CALCulate<cnum>:MARKer<mkr>:DELTA?

Return Type Bool (1 = ON, 0 = OFF)

Overlapping? No

Default OFF

CALCulate<cnum>:MARKer<mkr>:DIScrete <ON|OFF>

(Read-Write) Set whether the specified marker to be a discrete marker or not.

Parameter

<cnum> Channel number of measurement. This channel must have selected a measurement. If not specified, <cnum> is default to 1.

<mkr> Marker number. Range: 1 or -10; if unspecified, default to marker 1.

<ON|OFF> ON (or 1) - Discrete marker displaying the data of the actual sweep point.
OFF (or 0) - Continuous marker also displaying interpolation data.

Example

```
CALC:MARK:DISC ON
calculate2:marker8:discrete off
```

Query Syntax CALCulate<cnum>:MARKer<mkr>:DIScrete?

Return Type Bool (1 = ON, 0 = OFF)

Overlapping? No

Default OFF

CALCulate<cnum>:MARKer<mkr>:FORMat <char>

(Read-Write) Set the data format of the marker. That is the format of the marker data returned by using the query command (CALC:MARK:Y?) and the display format of the marker reading. The marker format and the display format of measurement may be different.

Parameter

<cnum> Channel number of measurement. This channel must have selected a measurement. If not specified, <cnum> is default to 1.

<mkr> Marker number. Range: 1 or -10; if unspecified, default to marker 1.

Data format of the marker Options:

DEFault - The same to the selected format of measurement

MLINear - Linear value

MLOGarithmic - Logarithm value

IMPedance - (R+jX)

ADMittance - (G+jB)

<char> PHASe - Phase

IMAGinary - Imaginary part (Im)

REAL - Real part (Re) 1

POLar - Polar Coordinates (Re, Im)

GDELay - Group delay

LINPhase - Linear/phase

LOGPhase - Logarithm/phase

Example

```
CALC:MARK:FORMat MLIN
calculate2:marker8:format Character
```

Query Syntax CALCulate<cnum>:MARKer<mkr>:FORMat?

Return Type Char

Overlapping? No

Default DEFault

CALCulate<cnum>:MARKer<mkr>:FUNCTion:APEak:EXCursion <num>

(Read/Write) Set the noise value of the peak amplitude for the specified marker. The noise value determines the "peak". Used during ppeak search (next peak, right peak, left peak).

Parameter

<num>	Channel number of measurement. This channel must have selected a measurement. If not specified, <num> is default to 1.
<num>	Noise value. Value range: -500 - 500 Note: This command receives MIN and MAX parameters. See SCPI Syntax for detail.

Example

```
CALC:MARK:FUNC:APE:EXC 10
calculate2:marker8:function:apeak:excursion maximum
```

Query Syntax

CALCulate<num>:MARKer<num>:FUNCTion:APEak:EXCursion?

Return Type Char

Overlapping? No

Default 3

CALCulate<num>:MARKer<num>:FUNCTion:APEak:THReshold <num>

(Read-Write) Set the reference peak value of the specified marker. During peak search, if a certain peak (according to the standard set by the EXCursion command) is lower than this reference value, it is considered as an invalid peak. Used during ppeak search (next peak, right peak, left peak).

Parameter

<num>	Channel number of measurement. This channel must have selected a measurement. If not specified, <num> is default to 1.
<num>	Marker number. Range: 1 or -10; if unspecified, default to marker 1.
<num>	Reference value. Value range: -500 - 500 Note: This command receives MIN and MAX parameters. See SCPI Syntax for detail.

Example

```
CALC:MARK:FUNC:APE:THR -40
calculate2:marker8:function:apeak:threshold -55
```

Query Syntax CALCulate<num>:MARKer<num>:FUNCTion:APEak:THReshold?

Return Type Char

Overlapping? No

Default -100

CALCulate<cnum>:MARKer<mkr>:FUNCtion:DOMain:USER <range>

(Read-write) Assign the specified marker to a user domain. The X-axis range of the marker is the span of the specified user domain. User domain span is usually set using CALC:FUNC:DOM:USER:START and STOP commands, except for user domain 0, whose span is fixed to be the full span of the analyzer.

Each channel shares 10 domains (the trace statistics are also used), and multiple markers can use the same domain.

Parameter

<cnum>	Channel number of measurement. This channel must have selected a measurement. If not specified, <cnum> is default to 1.
<mkr>	Marker number. Range: 1 or -10; if unspecified, default to marker 1.
<range>	User filed. Range: 0 - 9 0 Full bandwidth of the analyzer 1 - 9: self-defining user domain

Example

```
CALC:MARK:FUNC:DOM:USER 1
calculate2:marker8:function:domain:user 1
```

Query Syntax

CALCulate<cnum>:MARKer<mkr>:FUNCtion:DOMain:USER?
Return to the user domain where the marker is.

Return Type

Char

Overlapping? No

Default 0 - Full bandwidth

CALCulate<cnum>:MARKer<mkr>:FUNCtion:DOMain:USER:START <start>

(Read-Write) Set the start value of the X-axis span of the specified marker.

Use CALC:MARK:FUNC:DOM:USER<range> command to set the domain number.

Use CALC:FUNC:DOM:USER:STOP command to set the end value.

Note: If the marker is assigned to user domain 0 (full bandwidth), USER:START and STOP commands will be in error (start and end values cannot be set for "Full Bandwidth").

Note: This command shares the same function with CALC:FUNC:DOM:USER:STAR command.

Parameter

<cnum>	Channel number of measurement. This channel must have selected a measurement. If not specified, <cnum> is default to 1.
<mkr>	Marker number. Range: 1 or -10; if unspecified, default to marker 1.
<start>	MIN of analyzer X-axis.

Example

```
CALC:MARK:FUNC:DOM:USER:START 500E6
calculate2:marker8:function:domain:user:start 1e12
```

Query Syntax `CALCulate<cnum>:MARKer<mkr>:FUNction:DOMain:USER:START?`
 Return Type `Char`

Overlapping? `No`

Default `MAX of analyzer X-axis`

CALCulate<cnum>:MARKer<mkr>:FUNction:DOMain:USER:STOP <stop>

(Read-Write) Set the end value of the X-axis span of the specified marker.

Use `CALC:MARK:FUNC:DOM:USER<range>` command to set the domain number.

Use `CALC:FUNC:DOM:USER:START` command to set the start value.

Note: If the marker is assigned to user domain 0 (full bandwidth), `USER:START` and `STOP` commands will be in error (start and end values cannot be set for "Full Bandwidth").

Note: This command shares the same function with `CALC:FUNC:DOM:USER:STOP` command.

Parameter

<cnum> Channel number of measurement. This channel must have selected a measurement. If not specified, <cnum> is default to 1.

<mkr> Marker number. Range: 1 or -10; if unspecified, default to marker 1.

<stop> End value of the X- axis. Value range: real number between MINimum and MAXimum of the X-axis of the X-axis.

Example

```
CALC:MARK:FUNC:DOM:USER:STOP 500e6
calculate2:marker8:function:domain1:user:stop 1e12
```

Query Syntax `CALCulate<cnum>:MARKer<mkr>:FUNction:DOMain:USER:STOP?`

Return Type `Char`

Overlapping? `No`

Default `MAX of the analyzer's X-axis.`

CALCulate<cnum>:MARKer<mkr>:FUNction:EXECute [<func>]

(Read only) Performs the specified search function immediately. If no function is specified, the current function will be executed. Use `CALC:MARK:FUNction:SEL` command to select the function.

Parameter

<cnum> Channel number of measurement. This channel must have selected a measurement. If not specified, <cnum> is default to 1.

<mkr> Marker number. Range: 1 or -10; if unspecified, default to marker 1.

Optional parameter, indicating the search function to be executed. Options:

MAXimum - Max value
 MINimum - Min value
 RPEak - Right peak value
 <func> LPEak - Left peak value
 NPEak - Next peak value
 TARGet - Target
 LTARget - Left target
 RTARget - Right target

Example

```
CALC:MARK:FUNC:EXEC
calculate2:marker2:function:execute maximum
```

Query Syntax NONE

Overlapping? No

Default NONE

CALCulate<cnum>:MARKer<mkr>:FUNCTion[:SElect] <char>

(Read-Write) Set the search function of the marker. Use CALC:MARK:FUNC:EXEC command to execute the search function, or use CALC:MARK:FUNC:TRAC ON command for automatic search after each sweeping.

Parameter

<cnum> Channel number of measurement. This channel must have selected a measurement. If not specified, <cnum> is default to 1.

<mkr> Marker number. Range: 1 or -10; if unspecified, default to marker 1.

marker functions, options:

MAXimum - Max value
 MINimum - Min value
 RPEak - Right peak value
 <char> LPEak - Left peak value
 NPEak - Next peak value
 TARGet - Target
 LTARget - Left target
 RTARget - Right target

Example

```
CALC:MARK:FUNC MAX
calculate2:marker8:function:select ltarget
```

Query Syntax CALCulate<cnum>:MARKer<mkr>:FUNCTion[:SElect]?

Overlapping? No
 Default MAX

CALCulate<cnum>:MARKer<mkr>:TARGet <num>

(Read-Write) Set the target value for the target search (CALC:MARK:FUNC:SEL <TARGet | RTARGet | LTARGet>).

Parameter

<cnum> Channel number of measurement. This channel must have selected a measurement. If not specified, <cnum> is default to 1.
 <mkr> Marker number. Range: 1 or -10; if unspecified, default to marker 1.
 <num> Target value to be searched. No unit.

Example

```
CALC:MARK:TARG 2.5
calculate2:marker8:target -10.3
```

Query Syntax CALCulate<cnum>:MARKer<mkr>:TARGet?

Return Type Char

Overlapping? No
 Default 0

CALCulate<cnum>:MARKer<mkr>:FUNCtion:TRACking <ON | OFF>

(Read-Write) Set the tracking function of the specified marker. The tracking function causes the marker to perform a search function after each sweep, which has the same effect as executing the CALC:MARK:FUNC:EXECute command once after each sweeping.

Parameter

<cnum> Channel number of measurement. This channel must have selected a measurement. If not specified, <cnum> is default to 1.
 <mkr> Marker number. Range: 1 or -10; if unspecified, default to marker 1.
 <ON | OFF> ON (or 1) - Perform the search function once after each sweeping.
 OFF (or 0) - Perform the search function only after receiving the CALC:MARK:FUNC:EXECute command.

Example

```
CALC:MARK:FUNC:TRAC ON
calculate2:marker8:function:tracking off
```

Query Syntax `CALCulate<cnum>:MARKer<mkr>:FUNCtion:TRACking?`

Return Type Bool (1 = ON, 0 = OFF)

Overlapping? No

Default OFF

CALCulate<cnum>:MARKer:REFerence[:STATe] <ON | OFF>

(Read-Write) Turn on or off the reference marker (marker 10). When the reference marker is turned off, the Δ marker will become an absolute marker.

Parameter

<cnum> Channel number of measurement. This channel must have selected a measurement. If not specified, <cnum> is default to 1.

<ON | OFF> ON (or 1) - On.
OFF (or 0) - Off.

Example

```
CALC:MARK:REF ON
calculate2:marker:reference:state OFF
```

Query Syntax `CALCulate<cnum>:MARKer:REFerence[:STATe]?`

Return Type Bool (1 = ON, 0 = OFF)

Overlapping? No

Default OFF

CALCulate<cnum>:MARKer:REFerence:X <num>

(Read-Write) Set or return the absolute value of the x-axis of the reference marker (marker 10).

<cnum> Channel number of measurement. This channel must have selected a measurement. If not specified, <cnum> is default to 1.

<num> Value of the X- axis of the reference marker. Value range: any value within the domain where the marker is.

Example

```
CALC:MARK:REF:X 1e9
calculate2:marker:reference:x 1e6
```

Query Syntax `CALCulate<cnum>:MARKer:REFerence:X?`

Return Type Char

Overlapping? No

Default If it is the first marker, it is at the midpoint of the X-axis; otherwise, it is at the active marker.

CALCulate<cnum>:MARKer:REFerence:Y?

(Read only) Return the absolute value of the x-axis of the reference marker (marker 10).

Parameter

<cnum> Channel number of measurement. This channel must have selected a measurement. If not specified, <cnum> is default to 1.

Example

```
CALC:MARK:REF:Y?
calculate2:marker:reference:y?
```

Return Type Char

Overlapping? No

Default NONE

CALCulate<cnum>:MARKer<mkr>:TYPE <char>

(Read-Write) Set the type of the specified marker.

Parameter

<cnum> Channel number of measurement. This channel must have selected a measurement. If not specified, <cnum> is default to 1.

<mkr> Marker number. Range: 1 or -10; if unspecified, default to marker 1.

<char> Select:
 NORMal - If not moving or searching, the marker stays at the specified position on the X-axis.
 FIXed - The marker is fixed at the specified X or Y coordinate point.

Example

```
CALC:MARK:TYPE NORM
calculate2:marker2:type fixed
```

Query Syntax CALCulate<cnum>:MARKer<mkr>:TYPE?

Return Type Char

Overlapping? No

Default NORMAl

CALCulate<cnum>:MARKer<mkr>:SET <char>

(Read-Write) Set marker value of the specified marker as the specified parameter value.

Parameter

<cnum> Channel number of measurement. This channel must have selected a measurement. If not specified, <cnum> is default to 1.

<mkr> Marker number. Range: 1 or -10; if unspecified, default to marker 1.

Parameter. Options:

CENTER - Set the marker value to the center value.

SPAN - Set the marker value to the span value, which is determined by the Δ marker and the reference marker. It is invalid without the Δ marker.

<char> START - Set the marker value to the start value.

STOP - Set the marker value to the stop value.

RLEVel - Set the marker value as the reference level.

DELay - Set the marker value as the group delay.

Example

```
CALC:MARK:SET CENT
calculate2:marker8:set span
```

Query Syntax CALCulate<cnum>:MARKer<mkr>:SET?

Return Type Char

Overlapping? No

Default NONE

CALCulate<cnum>:MARKer<mkr>[:STATe] <ON|OFF>

(Read-Write) Turn on/off the specified marker. marker 10 is a reference marker. Use the CALC:MARK:AOff command to turn off all markers.

Parameter

<cnum> Channel number of measurement. This channel must have selected a measurement. If not specified, <cnum> is default to 1.

<mkr> Marker number. Range: 1 or -10; if unspecified, default to marker 1.

<ON|OFF> ON (or 1) - On.
OFF (or 0) - Off.

Example `CALC:MARK ON`
`calculate2:marker8 on`

Query Syntax `CALCulate<cnum>:MARKer<mkr>:STATe?`

Return Type Bool (1 = ON, 0 = OFF)

Overlapping? No

Default Off

CALCulate<cnum>:MARKer<mkr>:X <num>

(Read-Write) Set the X- axis value of the marker (frequency, power, time). If the marker is a Δ marker, the data set or queried is the data relative to the reference marker.

Parameter

<cnum> Channel number of measurement. This channel must have selected a measurement. If not specified, <cnum> is default to 1.

<mkr> Marker number. Range: 1 or -10; if unspecified, default to marker 1.

<num> Any x-axis value within the marker measurement range.
Note: This command receives MIN and MAX parameters. See SCPI Syntax for detail.

Example `CALC:MARK:X 100Mhz`
`calculate2:marker8:x maximum`

Query Syntax `CALCulate<cnum>:MARKer<mkr>:X?`

Return Type Char

Overlapping? No

Default If it is the first marker, it is at the midpoint of the X-axis; otherwise, it is at the active marker.

CALCulate<cnum>:MARKer<mkr>:Y?

(Read only) Read the Y-axis value of the marker. The format of the value is set by the `CALC:MARKER:FORMAT` command. If the marker is a Δ marker, the data is data relative to the reference marker.

The result of the query are two numbers:

Smith chart and polar format - (Real part, imaginary part)

Linear phase and logarithm phase - (Real part, imaginary part)

Other formats - (Value, 0)

Parameter

<cnun>	Channel number of measurement. This channel must have selected a measurement. If not specified, <cnun> is default to 1.
<mkr>	Marker number. Range: 1 or -10; if unspecified, default to marker 1.

Example

```
CALC:MARK:Y?
calculate2:marker3:y?
```

Query Syntax CALCulate<cnun>:MARKer<mkr>:Y?

Return Type Char

Overlapping? No

Default NONE

CALCulate<cnun>[:SElected]:MARKer<mk>:BWIDth:DATA?

(Write only) Read the result of bandwidth search.

Perform bandwidth search directly with CALCulate:MARKer:BWIDth -3 or CALCulate:MARKer:BWIDth:THReshold -3; CALCulate:MARKer:BWIDth:STATe ON

Parameter

<cnun>	Channel number of measurement. This channel must have selected a measurement. If not specified, <cnun> is default to 1.
<mk >	Marker index. For the time being, only the bandwidth search function of marker 1 is supported.

Example

```
CALC:MARK:BWID:STAT ON
CALC:MARK:BWID:DATA?
```

Query Syntax CALCulate<cnun>:SElected:MARKer1:BWIDth:DATA?
Return to the bandwidth value searched

Return Type Strings separated by commas (', '): bandwidth, center frequency, quality factor Q and loss.

Overlapping? No

Default NONE

CALCulate<cnun>[:SElected]:MARKer<mk>:BWIDth:THReshold <num>

(Read-Write) Set or query defined value of bandwidth used for bandwidth search For example, if the

bandwidth measured is 3dB, set <num> to -3. Then send the CALC:MARK:BWID:STAT ON command to activate bandwidth search.

Parameter

<num>	Channel number of measurement. This channel must have selected a measurement. If not specified, <num> is default to 1.
<mk >	Marker index. 1~9 correspond to markers 1~9, and 10 corresponds to reference marker.
<num>	Lower than the target value of the filter peak. Value range: -500 to 500

Example

```
CALC:MARK:BWID:THR -3
calculate2:selected:marker:bwid:threshold -2.513
```

Query Syntax CALCulate<cnum>:MARKer:BWIDth:THReshold?
Return to defined value of bandwidth

Return Type Char

Overlapping? No

Default -3

CALCulate<cnum>[:SELEcted]:MARKer:BWIDth:STATe <ON|OFF>

Read-Write ON: Activate markers 1 to 4 to calculate the filter bandwidth. OFF: Turn off bandwidth value display. Use the Close all markers command to close all markers or individual markers.

To search within the user domain using 'Bandwidth Search", first you need to activate marker 1 and set the desired User domain. Then send the CALC:MARK:BWID command.

Parameter

<cnum>	Channel number of measurement. This channel must have selected a measurement. If not specified, <cnum> is default to 1.
<ON OFF>	ON- Activate bandwidth search. OFF - Disable bandwidth search display.

Example

```
CALC:MARK:BWID:STAT ON
calculate2:selected:marker:bwid:state off
```

Query Syntax CALCulate<cnum>:MARKer:BWIDth:STATe?

Return Type Boolean (ON - Display on, OFF- Display off)

Overlapping? No

Default OFF

CALCulate<cnum>[:SELEcted]:MARKer:FUNCTion:DOMain:COUPlE <ON|OFF>

(Read-Write) marker search domain coupling. That is, the search domain of markers corresponding to all traces should apply the same settings.

Parameter

<cnum>	Channel number of measurement. This channel must have selected a measurement. If not specified, <cnum> is default to 1.
<ON OFF>	ON - Turn on search domain coupling. OFF - Turn off search domain coupling.

Example

```
CALC:MARK:FUNC:DOM:COUP ON
calculate2:selected:marker:function:domain:couple off
```

Query Syntax CALCulate<cnum>:MARKer:FUNCTion:DOMain:COUPlE?

Return Type Boolean (ON - Coupling on OFF - Coupling off)

Overlapping? No

Default OFF

CALCulate<cnum>[:SELEcted]:MARKer:FUNCTion:DOMain:STARt <num>

(Read-Write) Start value of search range.

Parameter

<cnum>	Channel number of measurement. This channel must have selected a measurement. If not specified, <cnum> is default to 1.
<num>	Start value of search range.

Example

```
CALC:MARK:FUNC:DOM:STAR 1e9
calculate2:selected:marker:function:domain:start 8.38e5
```

Query Syntax CALCulate<cnum>:MARKer:FUNCTion:DOMain:STARt?

Return Type Char

Overlapping? No

Default 0

CALCulate<cnum>[:SELEcted]:MARKer:FUNCTion:DOMain[:STATe] <ON|OFF>

(Read-Write) Set whether to use search domain when executing marker search.

Parameter

<cnun> Channel number of measurement. This channel must have selected a measurement. If not specified, <cnun> is default to 1.

<ON|OFF> ON - Search within the marker search domain.
OFF - Search within the entire sweep domain.

Example

```
CALC:MARK:FUNC:DOM ON
calculate2:selected:marker:function:domain:state off
```

Query
Syntax

CALCulate<cnun>:MARKer:FUNCTion:DOMain:STATe?

Return Type Boolean (ON - Search domain OFF - The whole sweep domain)

Overlapping? No

Default OFF

CALCulate<cnun>[:SELEcted]:MARKer:FUNCTion:DOMain:STOP <num>

(Read-Write) Stop value of search range.

Parameter

<cnun> Channel number of measurement. This channel must have selected a measurement. If not specified, <cnun> is default to 1.

<num> Stop value of search range.

Example

```
CALC:MARK:FUNCTion:DOMain:STOP 2e9
calculate2:selected:marker:function:domain:stop 2.3e9
```

Query
Syntax

CALCulate<cnun>:MARKer:FUNCTion:DOMain:STOP?

Return Type Char

Overlapping? No

Default 0

CALCulate<cnun>[:SELEcted]:MARKer<mk>:FUNCTion:PEXCursion <num>

(Read-Write) Set the peak offset quantity when executing peak value search.

Parameter

<cnm>	Channel number of measurement. This channel must have selected a measurement. If not specified, <cnm> is default to 1.
<mk >	Marker index. 1~9 correspond to markers 1~9, and 10 corresponds to reference marker.
<num>	Peak excursion value.

Example

```
CALC:MARK:FUNC:PEXC 3
calculate2:selected:marker2:function:pexcursion 1.2
```

Query Syntax

CALCulate<cnm>:MARKer:FUNCtion:PEXCursion?

Return Type Char

Overlapping? No

Default 3

CALCulate<cnm>[:SELEcted]:MARKer<mk>:FUNCtion:PPOLarity <char>

(Read-Write) Set the peak polarity of marker search.

Parameter

<cnm>	Channel number of measurement. This channel must have selected a measurement. If not specified, <cnm> is default to 1.
<mk>	Marker index. 1~9 correspond to markers 1~9, and 10 corresponds to reference marker.
<char>	POSitive - Positive peak value NEGative - Negative peak value BOTH - Positive and negative peak values

Example

```
CALC:MARK:FUNC:PEXC 3
calculate2:selected:marker2:function:pe1.2
```

Query Syntax

CALCulate<cnm>:MARKer:FUNCtion:PPOLarity?

Return Type Char(POSitive/NEGative/BOTH)

Overlapping? No

Default POSitive

CALCulate<cnm>[:SELEcted]:MARKer<mk>:FUNCtion:TARGet <num>

(Read-Write) Target value of marker search.

Parameter

<cnum>	Channel number of measurement. This channel must have selected a measurement. If not specified, <cnum> is default to 1.
<mk >	Marker index. 1~9 correspond to markers 1~9, and 10 corresponds to reference marker.
<num>	Target value of search.

Example

```
CALC:MARK3:FUNC:TARG 2.3
calculate2:selected:marker:function:target 12
```

Query Syntax

```
CALCulate<cnum>:MARKer:FUNCTion:TARGet?
```

Return Type Char

Overlapping? No

Default 0

CALCulate<cnum>[:SELEcted]:MARKer<mk>:FUNCTion:TTRansition <char>

(Read-Write) Specify target transition type when the marker is searching for the target value..

Parameter

<cnum>	Channel number of measurement. This channel must have selected a measurement. If not specified, <cnum> is default to 1.
<mk >	Marker index. 1~9 correspond to markers 1~9, and 10 corresponds to reference marker.
<ON OFF>	POSitive - Positive transition NEGative - Negative Conversion BOTH - Positive and Negative Conversion

Example

```
:MARK:FUNC:PEXC 3
calculate2:selected:marker4:function:pexcursion 1.2
```

Query Syntax

```
<cnum>:SELEcted:FUNCTion:TTRansition?
```

Return Type Char(POSitive/NEGative/BOTH)

Overlapping? No

Default BOTH

<num>[:SElected]:MARKer<mk>:FUNctio:n:PPOLarity <char>

(Read-Write) Set the type of marker search. This type of search is performed by CALCulate:MARKer:FUNctio:n:EXECute. You can also use the CALCulate:MARKer:FUNctio:n[:SElect] command to set the marker search type.

Parameter

<num>	Channel number of measurement. This channel must have selected a measurement. If not specified, <num> is default to 1.
<mk >	Marker index. 1~9 correspond to markers 1~9, and 10 corresponds to reference marker.
<char>	Options for search types: MAXimum - Max value MINimum - Min value PEAK - Next peak value LPEak - Left peak value RPEak - Right peak value TARget - Target value LTARget - Left target value RTARget - Right target value

Example

```
CALC:MARK:FUNC:PEXC 3
calculate2:selected:marker2:function:pexcursion 1.2
```

Query Syntax CALCulate<num>:MARKer:FUNctio:n:TYPE?

Return Type Char

Overlapping? No

Default MAXimum

Calc:Math Commands

Set the trace algorithm between the current measurement data and memory data.

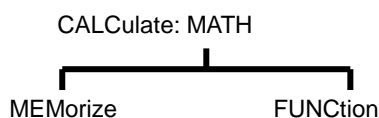

Note: CALCulate command functions on the selected measurement. This channel must have selected a measurement. Use CALC:PAR:SEL command to select the measurement.

CALCulate<num>:MATH:FUNctio:n <char>

(Read-Write) Set the algorithm of the selected measurement and memory trace. (Provided that memory has memory trace, see CALC:MATH MEM command for detail)

Parameter

<cnun> Channel number of measurement. This channel must have selected a measurement. If not specified, <cnun> is default to 1.

Algorithms: Options:

	ORMal	Data
<char>	ADD	Data+Memory
	SUBTract	Data-Memory
	MULTiPLY	Data*Memory
	DIVide	Data/Memory

Example

```
CALC:MATH:FUNC NORM calculate2:math:function subtract
```

Query Syntax CALCulate<cnun>:MATH:FUNction?

Return Type Char

Overlapping? No

Default NORMal

CALCulate<cnun>:MATH:MEMorize

(Write only) Save the selected measurement trace data to the memory. (Data->Memory)

Parameter

<cnun> Channel number of measurement. This channel must have selected a measurement. If not specified, <cnun> is default to 1.

Example

```
CALC:MATH:MEM calculate2:math:memorize
```

Query Syntax NA

Overlapping? No

Default NONE

Calc:MStatistics Commands

Data statistics function.

CALCulate[:SElected]:MStatistics



Note: CALCulate command functions on the selected measurement. This channel must have selected a measurement. Use CALC:PAR:SEL command to select the measurement.

Note: The data statistics function can also be turned on by the CALCulate<num>:FUNCTION:STATistics[:STATe] <ON|OFF> command.

CALCulate<num>[:SElected]:MStatistics:DATA?

(Write only) Get statistics value.

Parameter

<num> Channel number of measurement. This channel must have selected a measurement. If not specified, <num> is default to 1.

Example

```
:DATA:CUST:CAT?
:selected:data:sdata?
```

Query Syntax

```
<num>[:SElected]:FUNCTION:DATA?
```

Return Type

Strings separated by commas (','): average value, standard deviation, difference between max and min values.

Overlapping? No

Default value NONE

CALCulate<num>[:SElected]:MStatistics[:STATe] <ON | OFF>

(Read-Write) Turn on/off display of statistics value for traces. The same as CALCulate<num>:FUNCTION:STATistics[:STATe] <ON|OFF>

Parameter

<num> Channel number of measurement. This channel must have selected a measurement. If not specified, <num> is default to 1.

<ON | OFF> ON (or 1) - Show statistics value
OFF (or 0) - Hide statistics value

Example

```
CALC:SEL:MST:STAT OFF
calculate2:selected:mstatistics:state on
```

Query

```
CALCulate<num>:MStatistics?
```

Syntax

Return Type Bool (1 = ON, 0 = OFF)

Overlapping? No

Default OFF

Calc:Normalize Commands

Normalized settings for receiver power calibration.

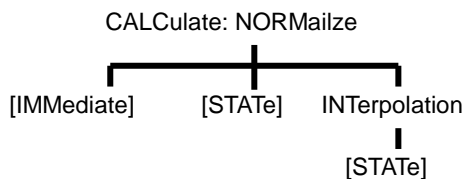

(Note: Commands of this command block are not provided temporarily)

Store and callback receiver power calibration (with .CST file command):

SENS:CORR:CSET:SAVE

SENS:CORR:CSET[:SEL]

Or use these two commands and specify the file extension as .STA or .CST:

MMEM:LOAD

MMEM:STOR

Note: CALCulate command functions on the selected measurement. This channel must have selected a measurement. Use CALC:PAR:SEL command to select the measurement.

CALCulate<cnum>:NORMailze[:IMMEDIATE]

(Read-write) Stores measurement data in the measured “Divisor” buffer to be called during normalized data processing. This command cannot be applied during ratio measurement (such as S-parameter measurement). The receiver power calibration can only be performed when the selected measurement is a non-ratio measurement.

Parameter

<cnum> Channel number of measurement. This channel must have selected a measurement. If not specified, <cnum> is default to 1.

Example

```
CALC:NORM
calculate1:normalize:immediate
```

Query
Syntax

NA

Overlapping? No

Default NONE

CALCulate<cnum>:NORMalize:STATe <ON | OFF>

(Read and Write) Set whether to normalize the current measurement. Normalization only applies to non-ratio measurements. Non-ratio measurement data is used for receiver power calibration.

Parameter

<cnum> Channel number of measurement. This channel must have selected a measurement. If not specified, <cnum> is default to 1.

<ON | OFF> ON (or 1) - Normalization.
OFF (or 0) - No normalization.

Example `:CORR:STAT ON calculate2:correction:state off`

Query Syntax `CALCulate<cnum>:NORMalize:STATe?`

Return Type Bool (1 = ON, 0 = OFF)

Overlapping? No

Default OFF

CALCulate<cnum>:NORMalize:INTerpolation[:STATe] <ON | OFF>

(Read-Write) Turn on or off the interpolation function of normalization. Normalization only applies to non-ratio measurements. Non-ratio measurement data is used for receiver power calibration.

Parameter

<cnum> Channel number of measurement. This channel must have selected a measurement. If not specified, <cnum> is default to 1.

<ON | OFF> ON (or 1) - Enable interpolation.
OFF (or 0) - Disable interpolation.

Example `CALC:NORM:INT ON
calculate2:normalize:interpolation:state off`

Query Syntax `CALCulate<cnum>:NORMalize:INTerpolation[:STATe]?`

Return Type Bool (1 = ON, 0 = OFF)

Overlapping? No

Default ON

Calc:Parameter Commands

Inquire, create, select or delete the measurement.

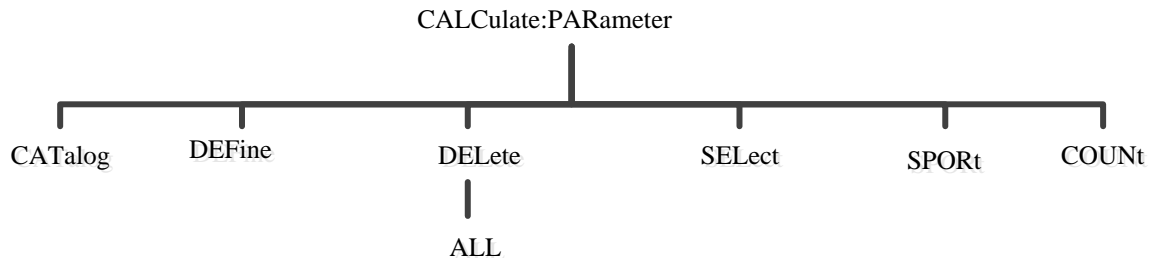

Note: CALCulate command functions on the selected measurement. This channel must have selected a measurement. Use CALC:PAR:SEL command to select the measurement.

CALCulate<cnum>:PARAmeter:CATalog?

(Read only) Return the name and parameter of all measurement of the specified channel.

Parameter

<cnum> Channel number. If not specified, <cnum> is default to 1.

Example `CALC:PAR:CAT? calculate2:parameter:catalog?`

Query Syntax `CALCulate<cnum>:PARAmeter:CATalog?`

Return Type String - "<Mname>,<param>,[<Mname>,<param>...]"

Overlapping? No

Default "CH1_WIN1_LINE1_PARAM1,S11"

CALCulate<cnum>:PARAmeter:COUNT <num>

(Read-Write) Set/get the measurement (trace) number of the specified channel in the specified window. Among which, owing to channel number and window number share the same parameter during setting, it is the measurement number created on the specified window; while the query is based on the channel, so query is to inquire all the trace number of the entire channel, other than the trace number of the specified channel in the current window.

Note: If the measurement trace number set is less than the current one, it will delete several additional measurements with index ranking behind, and these measurement cannot be recovered. It also includes the background internal measurement after calibration or required after calculating by balanced parameter.

Note: This command is compatible with Agilent ENA vector network analyzer; the channel number of the

created measurement is same with the window number.

Parameter

<num> Specified window number (also including channel number). If not specified, <num> is default to 1.

<num> Trace number.

Example

```
CALC:PAR:COUN // In Window 1, create 4 measurement traces of Channel 1 and display them.
CALC:PAR:COUN In Window 2, create 3 measurement traces of Channel 2 and display them.
```

Query Syntax

CALCulate:PARAmeter:COUNt?

Return Type Char

Overlapping? No

Default 1

CALCulate<num>:PARAmeter:DEFine <Mname>,<param>[,load]

(Write only) Create an measurement, but not display it.

If the window does not exist, use DISP:WIND:STATE command to create a window.

Use command DISP:WIND<wnum>:TRAC<tnum>:FEED <Mname> to display this measurement.

Before performing other setting, it first select the measurement (CALC<num>:PAR:SEL <mname>).

Parameter

<num> Create the Channel number of measurement. Value range:
1 - 64
if unspecified, default to 1.

<Mname> Measurement name (cannot share the same name with other measurement). Any non-null string bracketed by single bracket.

Parameter.

For S parameter measurement, select:

S11 | S22 | S12 | S21

For the following non-S parameter measurements, use: SENSE:SWEEP:SRCPort <1|2> command to specify the source port.

<param> For non-ratio measurement, select:

A | B | R1 | R2

For ratio measurement, select:

<param>	Description
AB	A/B
BA	B/A

AR1	A/R1
BR1	B/R1
AR2	A/R2
BR2	B/R2
R1A	R1/A
R2A	R2/A
R1B	R1/B
R2B	R2/B
2R1	R2/R1
R1R2	R1/R2

[load] Optional parameters. Device port provides load for measurement (only suitable for multi-port reflectance measurement). If the specified measurement is S parameter transmission measurement, then ignore this parameter.

Example `CALC:PAR:DEF 'Test',S12 calculate2:parameter:define 'test',s22`

Query Syntax NONE; see Calc:Par:Cat?

Overlapping? No

Default NONE

CALCulate<cnum>:PARAmeter:DELeTe [:NAME]<Mname>

(Write only) Delete the specified measurement.

Parameter

<cnum> Channel number of measurement. This channel must have selected a measurement. If not specified, <cnum> is default to 1.

<Mname> String - Measurement name.

Example `CALC:PAR:DEL 'TEST' calculate2:parameter:delete 'test'`

Query Syntax NA

Overlapping? No

Default NONE

CALCulate<cnum>:PARAmeter:DELeTe:ALL

(Write only) Delete all measurement on the specified channel.

Parameter

<cnum> Channel number of measurement. This channel must have selected a measurement. If not specified, <cnum> is default to 1.

Example `CALC:PAR:DEL:ALL calculate2:parameter:delete:all`

Query Syntax NA

Overlapping? No

Default NONE

CALCulate<cnum>:PARAmeter:SElect <Mname>

(Read-Write) Select measurement. Most CALC: commands require to select measurement first and then change setting. At the same time, This channel must have selected a measurement. Use command CALC:PAR:CAT? to inquire the name and parameter of all measurements of the channel.

Parameter

<cnum> Channel number to be selected for the measurement. If not specified, <cnum> is default to 1.

<Mname> String - Measurement name. (excluding parameter name)

Example `CALC:PAR:SEL 'TEST' calculate2:parameter:select 'test'`

Query Syntax CALCulate:PARAmeter:SElect?

Return Type String

Overlapping? No

Default NONE

CALCulate<cnum>:PARAmeter<tr>:SPORt <num>

(Read-Write) For non S parameter measurement, it is used for the specified source port. (only aimed at non S parameter measurement of 2-port)

Parameter

<cnum> Channel number of measurement. If not specified, <cnum> is default to 1.

<tr>	Trace number of the measurement. If unspecified, <tr> is set to 1.
<num>	Port number, with range from 1 to 2.

Example	CALC:PAR:SPOR 1 calculate2:parameter2:sport 2
---------	--

Query Syntax	CALCulate:PARAmeter:SPORt?
--------------	----------------------------

Return Type	Char
-------------	------

Overlapping?	No
--------------	----

Default	1
---------	---

Calc:RData Commands

Normally, when the user queries the analyzer for data, the total number of valid data expected to be returned is the same as the number of swept points. However, if the receiver data is queried during the instrument sweeping, the return value may contain a value of 0. For example, if the query data command is submitted at point 45 (sweeping of 201 points), then the data of the first 45 points is valid, and the data of the remaining points is a complex number of 0.

To avoid this, you can take the following measure: 1) Synchronize this query request with the end of the sweep. 2) Set the channel to the hold state.

Note: CALCulate command functions on the selected measurement. This channel must have selected a measurement. Use CALC:PAR:SEL command to choose a measurement for each channel.

CALCulate<cnum>:RDATA? <char>

(Read only) Return the receiver data of the selected measurement. When querying measurement data, please use the CALC:DATA command.

Parameter

<cnum>	Channel number of measurement. This channel must have selected a measurement. If not specified, <cnum> is default to 1.
--------	---

Receivers for selection:

A

B

<char>	R1
--------	----

R2

REF - Return data of R1 or R2, depending on the source port of the selected measurement set with the CALC command.

Example	GPIB.Write "INITiate:CONTInuous OFF" GPIB.Write "INITiate:IMMEDIATE;*wai" GPIB.Write "CALCulate:RDATA? A"
---------	---

Return data Char- two values for each data point.

Overlapping? No

Default NONE

Calc:RLimit Commands

Wave test setting.

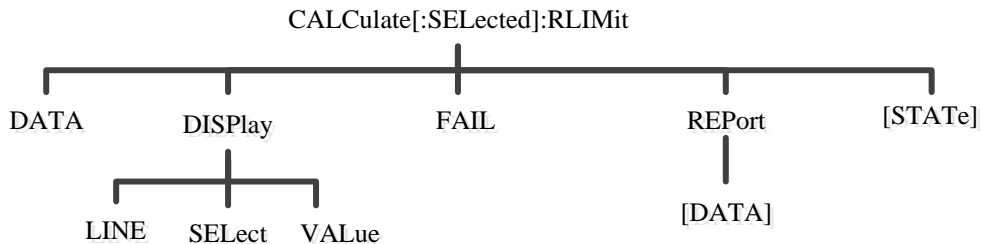

Note: CALCulate command functions on the selected measurement. This channel must have selected a measurement. Use CALC:PAR:SEL command to select the measurement.

CALCulate<cnum>[:SElected]:RLIMit:DATA <block>

(Read-Write) Set or inquire ripple limit table.

Parameter

<cnum> Channel number of measurement. This channel must have selected a measurement. If not specified, <cnum> is default to 1.

Data format
 N,type1,stimstart1,stimstop1,rippleval1, ,typeN,stimstartN,stimstopN,ripplevalN
 N - Number of ripple limit lines

<block> typen - Type of the nth limit line. 0: OFF 1: ON
 stimstartn - Start stimulus value of the nth limit line
 stimstopn - Stop stimulus value of the nth limit line
 ripplevaln - Wave value of the nth limit line (dB)

Example

```
CALC:SEL:RLIM:DATA 3;
calculate2:selected:rlimit:data 5;
```

Query Syntax CALCulate<cnum>:RLIMit:DATA?

Return Type Char

Overlapping? No

Default value NONE

CALCulate<num>[:SElected]:RLIMit:DISPlay:LINE <ON | OFF>

(Read-Write) Turn on/off the limit line display of ripple test.

Parameter

<num> Channel number of measurement. This channel must have selected a measurement. If not specified, <num> is default to 1.

<ON | OFF> ON (or 1) - Show limit line
OFF (or 0) - Hide imit line

Example

```
CALC:RLIM:DISP:LINE ON
calculate2:selected:rlimit:display:line off
```

Query
Syntax

```
CALCulate<num>:RLIMit:DISPlay:LINE?
```

Return Type Bool (1 = ON, 0 = OFF)

Overlapping? No

Default OFF

CALCulate<num>[:SElected]:RLIMit:DISPlay:SElect <num>

(Read-Write) Set or read the ripple limit line displayed by the ripple value.

Parameter

<num> Channel number of measurement. This channel must have selected a measurement. If unspecified, <num> is default to 1.

<num> Ripple limit segment.
Value range: 1 to 12.

Example

```
CALC:RLIM:DISP:SEL 1
calculate2:selected:rlimit:display:select 2
```

Query
Syntax

```
CALCulate<num>:RLIMit:DISPlay:SElect?
```

Return Type Char

Overlapping? No

Default 1

CALCulate<cnum>[:SELEcted]:RLIMit:DISPlay:VALue <char>

(Read-Write) Set/get the display type of ripple limit line.

Parameter

<cnum> Channel number of measurement. This channel must have selected a measurement. If not specified, <cnum> is default to 1.

<char> OFF - Hide the display of ripple limit value
 ABSolute - Display the absolute value of the ripple test
 MARgin - Display the margin value of the ripple test

Example

```
CALC:RLIM:DISP:VAL OFF
calculate2:selected:rlimit:display:value absolute
```

Query Syntax CALCulate<cnum>:RLIMit:DISPlay:VALue?

Return Type Char (OFF/ABSolute/MARgin)

Overlapping? No

Default OFF

CALCulate<cnum>[:SELEcted]:RLIMit:FAIL?

(Read only) Get the result of activating track line ripple. Return 1 (TRUE) indicates ripple test success; Return 0 (FALSE) indicates ripple test failure. If the bandwidth test is not enabled, FALSE is always read.

Parameter

<cnum> Channel number of measurement. This channel must have selected a measurement. If not specified, <cnum> is default to 1.

Example

```
CALC:RLIM:FAIL?
```

Query Syntax CALCulate<cnum>RLIMit:FAIL?

Return Type Bool (TRUE, FALSE)

Overlapping? No

Default NONE

CALCulate<cnum>[:SELEcted]:RLIMit:REPort[:DATA]?

(Read only) Read the wave value of ripple test

The returned data is block data, including a total of 1 + Num (limit line number) x3 array data (ripple line). Here n is an integer between 1 and 12.

Data <0>: Ripple limit line number

Data <nx3-2>: Ripple limit line index

Data <nx3-1>: Ripple value

Data <nx3>: Ripple test results. 1: Failure 0: Success

Parameter

<cnum> Channel number of measurement. A measurement must be selected in the current channel. If not specified, <cnum> is default to 1.

Example `CALC:RLIM:REP?`

Query Syntax `CALCulate<cnum>:RLIMit:REPort:DATA?`

Return Type Block

Overlapping? No

Default NONE

CALCulate<cnum>[:SELEcted]:RLIMit[:STATe] <ON | OFF>

(Read-Write) Turn on or off ripple test function.

Parameter

<cnum> Channel number of measurement. This channel must have selected a measurement. If not specified, <cnum> is default to 1.

<ON | OFF> ON (or 1) - On.
OFF (or 0) - Off.

Example `CALC:RLIM ON`
`calculate2:selected:rlimit:state off`

Query Syntax `CALCulate<cnum>:RLIMit[:STATe]?`

Return Type Bool (1 = ON, 0 = OFF)

Overlapping? No

Default OFF

Calc:Smoothing Commands

Control the point-point smoothing. Smoothing is a technique to reduce noise, which is realized by averaging the adjacent points in the measurement traces. Smoothing amount is determined by the specified point or smooth aperture. Smoothing differs with CALC:AVERage, where CALC:AVERage is realized by averaging each data point in several sweeps.

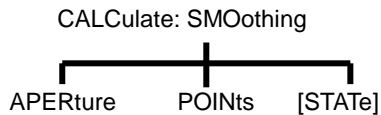

Note: CALCulate command functions on the selected measurement. This channel must have selected a measurement. Use CALC:PAR:SEL command to select the measurement.

CALCulate<cnum>:SMOothing:APERture <num>

(Read-Write) Set the smoothing amount, which is determined by the percentage of sweep point of the specified channel.

Parameter

<cnum>	Channel number of measurement. This channel must have selected a measurement. If not specified, <cnum> is default to 1.
<num>	Percentage. Value range: 1 - 25

Example

```
CALC:SMO:APER 2
calculate2:smoothing:aperture 20.7
```

Query
Syntax

```
CALCulate<cnum>:SMOothing:APERture?
```

Return Type Char

Overlapping? No

Default 2.5

CALCulate<cnum>:SMOothing:POINts <num>

(Read-Write) Set the data point used for smoothing.

Parameter

<cnum>	Channel number of measurement. This channel must have selected a measurement. If not specified, <cnum> is default to 1.
<num>	Data point for smoothing, from 1 to 25% of sweep point (at maximum). For example: if the sweep point of channel is 401, then the max point value = 101. Point number is rounded to the nearest odd number.

Example `CALC:SMO:POIN 50 calculate2:smoothing:points 21`

Query Syntax `CALCulate<cnum>:SMOothing:POINts?`

Return Type Char

Overlapping? No

Default 3

CALCulate<cnum>:SMOothing[:STATe] <ON | OFF>

(Read-Write) Turn on or off the smoothing function.

Parameter

<cnum> Channel number of measurement. This channel must have selected a measurement. If not specified, <cnum> is default to 1.

<ON | OFF> ON (or 1) - On.
OFF (or 0) - Off.

Example `CALC:SMO ON calculate2:smoothing:state off`

Query Syntax `CALCulate<cnum>:SMOothing[:STATe]?`

Return Type Bool (1 = ON, 0 = OFF)

Overlapping? No

Default OFF

Calc:Transform Commands

Set time domain conversion.

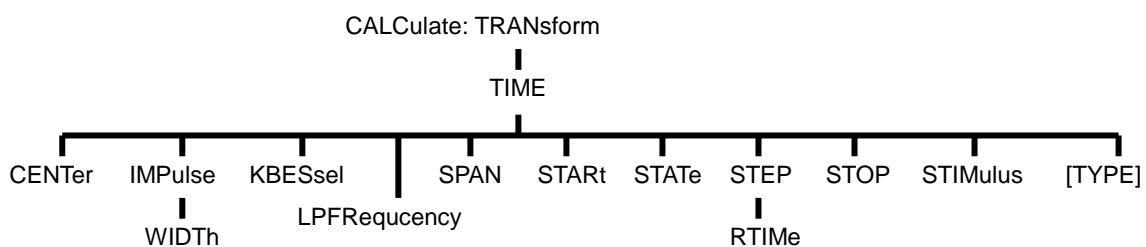

Note: CALCulate command works on the selected measurement. This channel must have selected a

measurement. Use CALC:PAR:SEL command to choose a measurement for each channel.

CALCulate<cnum>:TRANSform:TIME:CENTer <num>

(Read-Write) Set the center time of time domain measurement.

Parameter

<cnum> Channel number of measurement. here must be a selected measurement on that channel, If not specified, <cnum> is default to 1.

<num> Center time, in the unit of s. Value range:
 $\pm(\text{point}-1) / \text{frequency span}$
 Note: This command receives MIN and MAX parameters. See SCPI Syntax for detail.

Example

```
CALC:TRAN:TIME:CENT 1e-8
calculate2:transform:time:center 15 ps
```

Query
Syntax

CALCulate<cnum>:TRANSform:TIME:CENTer?

Return Type Char

Overlapping? No

Default 0

CALCulate<cnum>:TRANSform:TIME:IMPulse:WIDTh <num>

(Read-Write) Set the pulse width of the time domain conversion window.

Parameter

<cnum> Channel number of measurement. here must be a selected measurement on that channel, If not specified, <cnum> is default to 1.

<num> Pulse width, in seconds; value range:
 $6/\text{frequency span to } 1.39) / \text{frequency span}$

Example

```
CALC:TRAN:TIME:IMP:WIDTh 1.5e-10
calculate2:transform:time:impulse:width 2e-10
```

Query
Syntax

CALCulate<cnum>:TRANSform:TIME:IMPulse:WIDTh?

Return Type Char

Overlapping? No

Default .98 /Default width

CALCulate<cnum>:TRANSform:TIME:KBESsel <num>

(Read-Write) Set the beta value of time domain window.

Parameter

<cnum> Channel number of measurement. here must be a selected measurement on that channel, If not specified, <cnum> is default to 1.

<num> Kaiser window Beta value. in the unit of s. Value range:
0.0 to 13.0

Example

```
CALC:TRAN:TIME:KBES 10
calculate2:transform:time:kbessel 13
```

Query
Syntax

CALCulate<cnum>:TRANSform:TIME:KBESsel?

Return Type Char

Overlapping? No

Default 6

CALCulate<cnum>:TRANSform:TIME:LPFREQuency

(Write only) Set the initial frequency of time domain in the low pass mode,

Parameter

<cnum> Channel number of measurement. here must be a selected measurement on that channel, If not specified, <cnum> is default to 1.

Example

```
CALC:TRAN:TIME: LPFREQ
calculate2:transform:time:lpfrequency
```

Query
Syntax

NA

Overlapping? NONE

Default NONE

CALCulate<cnum>:TRANSform:TIME:SPAN <num>

(Read-Write) Set the time span of time domain measurement.

Parameter

<cnum> Channel number of measurement. here must be a selected measurement on that channel, If not specified, <cnum> is default to 1.

<num> Time span, in seconds; value range:
 0 ~ 2* [(point-1) / frequency span]
 Note: This command receives MIN and MAX parameters. See [SCPI Syntax](#).

Example

```
CALC:TRAN:TIME:SPAN 1e-8
calculate2:transform:time:span maximum
```

Query
Syntax

```
CALCulate<cnum>:TRANSform:TIME:SPAN?
```

Return Type Char

Overlapping? No

Default 20ns

CALCulate<cnum>:TRANSform:TIME:STARt <num>

(Read-Write) Set the start time of time domain measurement.

Parameter

<cnum> Channel number of measurement. here must be a selected measurement on that channel, If not specified, <cnum> is default to 1.

<num> Start time, in seconds; value range:
 $\pm(\text{point-1}) / \text{frequency span}$
 Note: This command receives MIN and MAX parameters. See [SCPI Syntax](#) for detail.

Example

```
CALC:TRAN:TIME:STAR 1e-8
calculate2:transform:time:start minimum
```

Query
Syntax

```
CALCulate<cnum>:TRANSform:TIME:STARt?
```

Return Type Char

Overlapping? No

Default -10 ns

CALCulate<cnum>:TRANSform:TIME:STATE <ON | OFF>

(Read-Write) Enable or disable the time domain conversion function.

Note: The sweep type must be linear frequency in the time domain conversion.

Parameter

<cnum>	Channel number of measurement. here must be a selected measurement on that channel, If not specified, <cnum> is default to 1.
<ON OFF>	ON (or 1) - Enable time domain. OFF (or 0) - Disable time domain.

Example

```
CALC:TRAN:TIME:STAT ON
calculate2:transform:time:state off
```

Query
Syntax

```
CALCulate<cnum>:TRANSform:TIME:STATE?
```

Return Type Bool (1 = ON, 0 = OFF)

Overlapping? No

Default OFF

CALCulate<cnum>:TRANSform:TIME:STOP <num>

(Read-Write) Set the stop time of time domain conversion .

Parameter

<cnum>	Channel number of measurement. here must be a selected measurement on that channel, If not specified, <cnum> is default to 1.
<num>	Stop time, in the unit of s. Value range: $\pm(\text{point}-1) / \text{frequency span}$ Note: This command receives MIN and MAX parameters. See SCPI Syntax for detail.

Example

```
CALC:TRAN:TIME:STOP 1e-8
calculate2:transform:time:stop maximum
```

Query
Syntax

```
CALCulate<cnum>:TRANSform:TIME:STOP?
```

Return Type Char

Overlapping? No

Default 10ns

CALCulate<cnum>:TRANSform:TIME:STEP:RTIME <num>

(Read-Write) Set the rise time of the domain window.

Parameter

<cnum> Channel number of measurement. Here must be a selected measurement on that channel, If not specified, <cnum> is default to 1.

<num> Rise time, in seconds; value range:
45/frequency span to 1.48) / frequency span

Example

```
CALC:TRAN:TIME:STEP:RTIM 1.5e-10
calculate2:transform:time:step:time 150ps
```

Query
Syntax

```
CALCulate<cnum>:TRANSform:TIME:STEP:RTIME?
```

Return Type Char

Overlapping? No

Default .99 /Default width

CALCulate<cnum>:TRANSform:TIME:STIMulus <char>

(Read and Write) Set the type of analog stimulus input to the device under test.

Parameter

<cnum> Channel number of measurement. There must be a selected measurement on that channel, if unspecified, default to 1.

Select:
STEP - Step
IMPulse - Impulse

<char> The step mode can only be used in time domain low pass mode (CALC:TRAN:TIME:TYPE is set to LPASs (Lowpass)). (Steps cannot be used when TYPE = BPASs).
: STIM STEP command sets: TYPE to LPASs mode
:TYPE BPASs command sets: STIM to IMPulse mode

Example

```
CALC:TRAN:TIME:STIM STEP
calculate2:transform:time:stimulus impulse
```

Query
Syntax

```
CALCulate<cnum>:TRANSform:TIME:STIMulus?
```

Return Type Char

Overlapping? No

Default IMPulse

CALCulate<cnum>:TRANSform:TIME[:TYPE] <char>

(Read-Write) Set the type of time domain measurement.

Parameter

<cnum> Channel number of measurement. There must be a selected measurement on that channel, if unspecified, default to 1.

The measurement types are:

LPASs - Time domain low pass. CALC:TRAN:TIME:LPFRequency command must be sent before calibration.

<char> BPASs - Time domain band pass.

The band pass mode can only be used when CALC:TRAN:TIME:STIM is set to impulse. (The band pass mode can not be used when STIM=STEP.)

: STIM STEP command sets: TYPE to LPASs mode

:TYPE BPASs command sets: STIM to IMPulse mode

Example

```
CALC:FILT:TIME BPAS :filter:gate:time:type notch
```

Query
Syntax

```
<cnum>:FILTer[:GATE]:TIME[:TYPE]?
```

Return Type Char

Overlapping? No

Default BPAS

Display Commands

Control the display setting of the front panel.

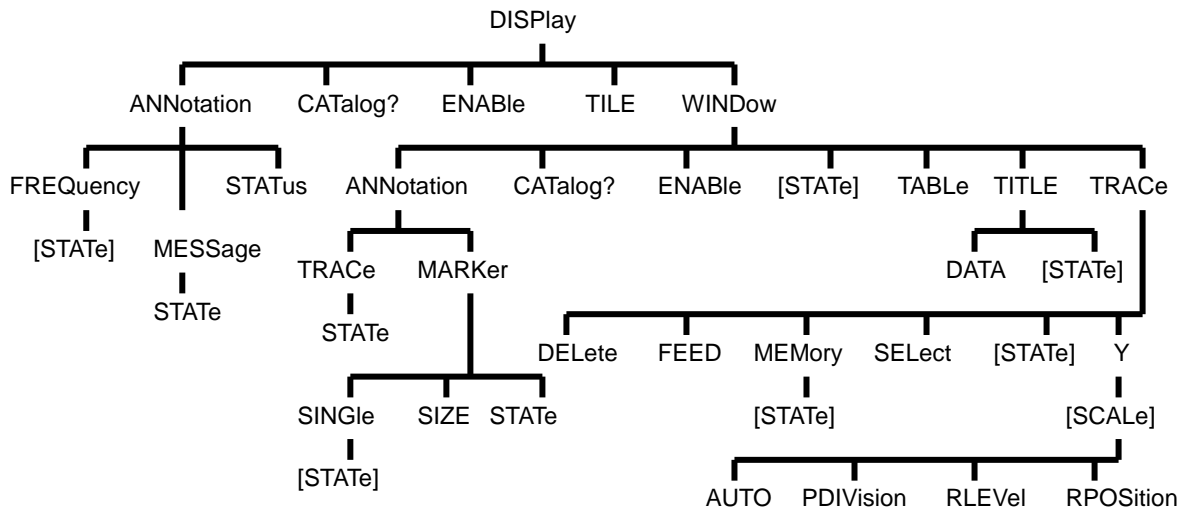
**DISPlay:ANNOtation:FREQUency[:STATe] <ON | OFF>**

(Read-Write) Turn on or off the entire display title bar on the frequency information.

Parameter

<ON | OFF> ON (or 1) - On.
OFF (or 0) - Off.

Example

```
DISP:ANN:FREQ ON display:annotation:frequency:state off
```

Query
Syntax

```
DISPlay:ANNOtation:FREQUency[:STATe]?
```

Return Type Bool (1 = ON, 0 = OFF)

Overlapping? No

Default ON (1)

DISPlay:ANNOtation:MESSage:STATe <ON | OFF>

(Read-Write) Allow or disallow to pop up the error message window.

Parameter

<ON | OFF> ON (or 1) - Allow to pop out the error message window.
OFF (or 0) - Disallow to pop out the error message window.

Example

```
DISP:ANN:MESS:STAT ON display:annotation:message:state off
```

Query
Syntax

```
DISPlay:ANNOtation:MESSage:STATe?
```

Return Type Bool (1 = ON, 0 = OFF)

Overlapping? No

Default ON (1)

DISPlay:ANNotation:STATus <ON|OFF>

(Read-Write) Turn on or off status bar at the bottom of the screen. The status bar displays information about the active window.

Parameter

<ON | OFF> ON (or 1) - Display the status bar.
OFF (or 0) - Turn off the status bar.

Example `DISP:ANN:STAT ON display:annotation:status off`

Query Syntax DISPlay:ANNotation:STATus?

Return Type Bool (1 = ON, 0 = OFF)

Overlapping? No

Default OFF

DISPlay:CATalog?

(Read only) Return all the existed window number.

Return Type String separated by comma.

Example If there are two windows Window 1 and 2, it returns:
"1,2"

Overlapping? No

Default NONE

DISPlay:ENABLE <ON | OFF>

(Read-Write) Setup the all analyzer windows whether to display all display message (without updating marker data). Measurement takes more CPU time than updating the display.

Parameter

<ON | OFF> ON (or 1) - Turn on the display.
OFF (or 0) - Turn off the display.

Example `DISP:ENAB ON display:enable off`

Query Syntax `DISPlay:ENABLE?`

Return Type Bool (1 = ON, 0 = OFF)

Overlapping? No

Default ON

DISPlay[:TILE]

(Write only) Display the window in stacking.

Example `DISP display:tile`

Overlapping? No

Default NONE

DISPlay:WINDow<wnum>:ANNotation:MARKer:SINGle[:STATE] <bool>

(Read-Write) Select to display only the marker value of active traces or all traces. See other SCPI commands for Marker .

Parameter

<wnum> Any existing window number (1-32), if if unspecified, default to 1.

<bool> ON (or 1) - Display the markers of active traces.
OFF (or 0) - Display the markers of all traces.

Example `DISP:WIND:ANN:MARK:SING ON display>window:annotation:marker:single off`

Query Syntax `DISPlay:WINDow:ANNotation:MARKer:SINGle?`

Return Type Bool (1 = ON, 0 = OFF)

Overlapping? No

Default ON

DISPlay:WINDow<wnum>:ANNotation:MARKer:SIZE <char>

(Read-Write) Setup the size of marker type. See other SCPI commands for [Curcor](#).

Parameter

<wnum> Any existing window number (1-32), if if unspecified, default to 1.
 <char> Type size when displaying the marker. The option is NORMal | LARGe.

Example

```
DISP:WIND:ANN:MARK:SIZE LARG display:window:annotation:marker:size normal
```

Query Syntax

```
DISPlay:WINDow:ANNotation:MARKer:SIZE?
```

Return Type Char

Overlapping? No

Default NORMal

DISPlay:WINDow<wnum>:ANNotation:MARKer:STATe <ON|OFF>

(Read-Write) Set whether the specified windows display the marker data (when the marker is on). See other SCPI commands for [Marker](#).

Parameter

<wnum> Any existing window number (1-32), if if unspecified, default to 1.
 <ON | OFF> ON (or 1) - Display the marker data
 OFF (or 0) - Hide the marker data.

Example

```
DISP:WIND:ANN:MARK:STAT ON display:window:annotation:marker:state off
```

Query Syntax

```
DISPlay:WINDow:ANNotation:MARKer:STATe?
```

Return Type Bool (1 = ON, 0 = OFF)

Overlapping? No

Default ON

DISPlay:WINDow<wnum>:ANNotation:TRACe:STATe <ON|OFF>

(Read-Write) Set whether the left window displays the trace status button.

Parameter

<wnum> Any existing window number (1-32),if if unspecified, default to 1.

<ON | OFF> ON (or 1) - Display the trace status button
OFF (or 0) - Hide the trace status button.

Example

```
DISP:WIND:ANN:TRAC:STAT ON
display>window:annotation:trace:state off
```

Query Syntax DISPlay:WINDow:ANNotation:TRACe:STATe?

Return Type Bool (1 = ON, 0 = OFF)

Overlapping? No

Default ON

DISPlay:WINDow<wnum>:CATalog?

(Read only) Display the trace number of the specified window.

Parameter

<wnum> Any existing window number (1-32), if if unspecified, default to 1.

Return Type String separated by comma.

Example

```
Window 1 has 4 traces:
DISPlay:WINDow1:CATalog?
then it will return:
1,2,3,4"
```

Overlapping? No

Default NONE

DISPlay:WINDow<wnum>:ENABle <ON | OFF>

(Read-Write) Set whether to display the analyzer display message in the specified windows (without updating marker data). Measurement takes more CPU time than updating the display.

Parameter

<wnum> Any existing window number (1-32),if if unspecified, default to 1.

<ON | OFF> ON (or 1) - Turn on the display
OFF (or 0) - Turn off the display.

Example **DISP:WIND:ENABLE ON**
 display:window1:enable off

Query Syntax DISPlay:WINDow<wnum>:ENABLE?

Return Type Bool (1 = ON, 0 = OFF)

Overlapping? No

Default ON

DISPlay:WINDow<wnum>[:STATe] <ON | OFF>

(Read-Write) Write: create or delete the widows on the screen; Read: view whether the window is existed.

Parameter

<wnum> Number of windows to be created; value range: 1 - 32.

<ON | OFF> ON (or 1) - Create window <wnum>.
 OFF (or 0) - Delect window <wnum>.

Example **DISP:WIND ON**
 display:window2:state off

Query Syntax DISPlay:WINDow<wnum>[:STATe]?

Return Type Boolean (1 = ON, 0 = OFF)

Overlapping? No

Default Window No. "1" ON

DISPlay:WINDow<wnum>:TABLE <char>

(Read-Write) Write: Display the specified table on the bottom of analyzer screen; Read: inquire the displaying data.

Parameter

<wnum> Any existing window number (1-32), if if unspecified, default to 1.

<char> Options of the table to be displayed:
 OFF | MARKer | LIMit | SEGMENT

Example `DISP:WIND:TABLE SEGM display:window:table off`

Query Syntax `DISPlay:WINDow:TABLE?`

Overlapping? No

Default OFF

DISPlay:WINDow<wnum>:TITLe:DATA <string>

(Read-Write) Set the window title. Use DISP:WIND:TITL:STAT OFF command to Turn on or off the title bar.

Parameter

<wnum> Any existing window number (1-32), if if unspecified, default to 1.

<string> The window title displayed is an arbitrary string bracketed by single quotes. If exceeding 50 characters, the title goes wrong and is invalid at the same time. The new title will replace the old one instead of added after it.

Example `DISP:WIND:TITL:DATA 'hello'`
`display:window2:title:data 'hello'`

Query Syntax `DISPlay:WINDow<wnum>:TITLe:DATA?`

Return Type String

Overlapping? No

Default NONE

DISPlay:WINDow<wnum>:TITLe[:STATe] <ON | OFF>

(Read-Write) Display or Turn off the window title. After closing, title string persists to facilitate the re-display after turning on.

Parameter

<wnum> Any existing window number (1-32), if if unspecified, default to 1.

<ON | OFF> ON (or 1) - Display window title.
 OFF (or 0) - Turn off window title.

Example `DISP:WIND:TITL ON`
`Display:window1:title:state off`

Query Syntax **DISPlay:WINDow<wnum>:TITLe[:STATe]?**

Return Type Bool (1 = ON, 0 = OFF)

Overlapping? No

Default ON

DISPlay:WINDow<wnum>:TRACe<tnum>:DELeTe

(Write only) Removes the specified trace from the specified window, without deleting the trace-related measurements.

Parameter

<wnum> Any existing window number (1-32), if unspecified, default to 1.

<tnum> Trace number to be deleted. If unspecified, set to 1.

Example

```
DISP:WIND:TRAC:DEL
display:window2:trace2:delete
```

Query Syntax NONE

Overlapping? No

Default NONE

DISPlay:WINDow<wnum>:TRACe<tnum>:FEED <name>

(Write only) Create a new trace <tnum> associated with measurement <name> in the window <wnum>. This command should be executed immediately after using CALC:PAR:DEF<name>,<parameter> command to create a new measurement.

A trace can be associated with only one measurement.

Parameter

<wnum> Any existing window number (1-32); if not specified, default to 1.

<tnum> Trace number to be created. Value range:
1 - 8

<name> Name of measurement defined by using CALC:PAR:DEF<name>,<parameter> command.

Example

```
DISP:WIND:TRAC:FEED 'test'
```

```
display>window2:trace2:feed 'test'
```

Query
Syntax NONE

Overlapping? No

Default "CH1_WIN1_LINE1_PARAM1"

DISPlay:WINDow<wnum>:TRACe<tnum>MEMory[:STATe] <ON | OFF>

(Read-Write) Turn on or off the memory trace.

Parameter

<wnum> Any existing window number (1-32), if if unspecified, default to 1.

<tnum> Any existing trace number; if not specified, default to 1.

<ON | OFF> ON (or 1) - Turn on the memory trace.
OFF (or 0) - Turn off the memory trace.

Example

```
DISP:WIND:TRAC:MEM ON
display>window2:trace2:memory:state off
```

Query
Syntax DISPlay:WIND<wnum>:TRACe<tnum>:MEMory[:STATe]?

Return Type Bool (1 = ON, 0 = OFF)

Overlapping? No

Default OFF

DISPlay:WINDow<wnum>:TRACe<tnum>:SELEct

(Write only) Activate the speicified traces on the specified windows.

Parameter

<wnum> Any existing window number (1-32); if not specified, default to 1.

<tnum> Any existing trace number; if not specified, default to 1.

Example

```
DISP:WIND:TRAC:SEL
display>window2:trace2:select
```

Query NONE

Syntax

Overlapping? No

Default NONE

DISPlay:WINDow<wnum>:TRACe<tnum>[:STATe] <ON | OFF>

(Read-Write) Display or Turn off the specified trace in the specified window. After closing the trace, the measurement is still active.

Parameter

<wnum> Any existing window number (1-32), if unspecified, default to 1.

<tnum> Any existing trace number. If unspecified, set to 1.

<ON | OFF> ON (or 1) - Turn on the trace.
OFF (or 0) - Turn off the trace.

Example

```
DISP:WIND:TRAC ON display:window2:trace2:state off
```

Query Syntax

```
DISPlay:WIND<wnum>:TRACe<tnum>[:STATe]?
```

Return Type Bool (1 = ON, 0 = OFF)

Overlapping? No

Default ON

DISPlay:WINDow<wnum>:TRACe<tnum>:Y[:SCALe]:AUTO

(Write only) Perform Auto Scale function for the specified traces in the specified window, to provide the most appropriate display. The auto scale can only be performed after sending a command, but it cannot guarantee the trace has been in auto scale status.

Parameter

<wnum> Any existing window number (1-32), if unspecified, default to 1.

<tnum> Any existing trace number. If unspecified, set to 1.

Example

```
DISP:WIND:TRAC:Y:AUTO display:window2:trace2:y:scale:auto
```

Query Syntax

NA

Overlapping? No

Default NONE

DISPlay:WINDow<wnum>:TRACe<tnum>:Y[:SCALe]:PDIVision <num>

(Read-Write) Set the scale of Y-axis of the specified traces in the specified window.

Parameter

<wnum> Any existing window number (1-32), if if unspecified, default to 1.

<tnum> Any existing trace number. If unspecified, set to 1.

<num> Scale value, the range of which relies on the display format and measurement field.
Note: This command receives MIN and MAX parameters. See SCPI Syntax for detail.

Example

```
DISP:WIND:TRAC:Y:PDIV 1
display>window2:trace2:y:scale:pdivision maximum
```

Query
Syntax

```
DISPlay:WINDow<wnum>:TRACe<tnum>:Y[:SCALe]:PDIVision?
```

Return Type Char

Overlapping? No

Default 10

DISPlay:WINDow<wnum>:TRACe<tnum>:Y[:SCALe]:RLEVel <num>

(Read-Write) Set the reference value of Y-axis of the specified traces in the specified window.

Parameter

<wnum> Any existing window number (1-32), if if unspecified, default to 1.

<tnum> Any existing trace number. If unspecified, set to 1.

<num> Reference level value. The range of the reference value depends on the display format and measurement field.
Note: This command receives MIN and MAX parameters. See SCPI Syntax for detail.

Example

```
DISP:WIND:TRAC:Y:RLEV 0
display>window2:trace2:y:scale:rlevel minimum
```

Query
Syntax

```
DISPlay:WINDow<wnum>:TRACe<tnum>:Y[:SCALe]:RLEVel?
```

Return Type Char

Overlapping? No

Default NONE

DISPlay:WINDow<wnum>:TRACe<tnum>:Y[:SCALe]:RPOSition <num>

(Read-Write) Set the reference position of the specified traces in the specified window.

Parameter

<wnum> Any existing window number (1-32), if if unspecified, default to 1.

<tnum> Any existing trace number. If unspecified, set to 1.

<num> Reference position on the screen. Measuring method: starting from the bottom of the screen, regard a horizontal grid as a span.

Range: 0-10

Note: This command receives MIN and MAX parameters. See SCPI Syntax for detail.

Example

```
DISP:WIND:TRAC:Y:RPOS 0
display:window2:trace2:y:rposition maximum
```

Query
Syntax

DISPlay:WINDow<wnum>:TRACe<tnum>:Y[:SCALe]:RPOSition?

Return Type Char

Overlapping? No

Default 5

Note: The below commands are only available in 1.2.0 or above.

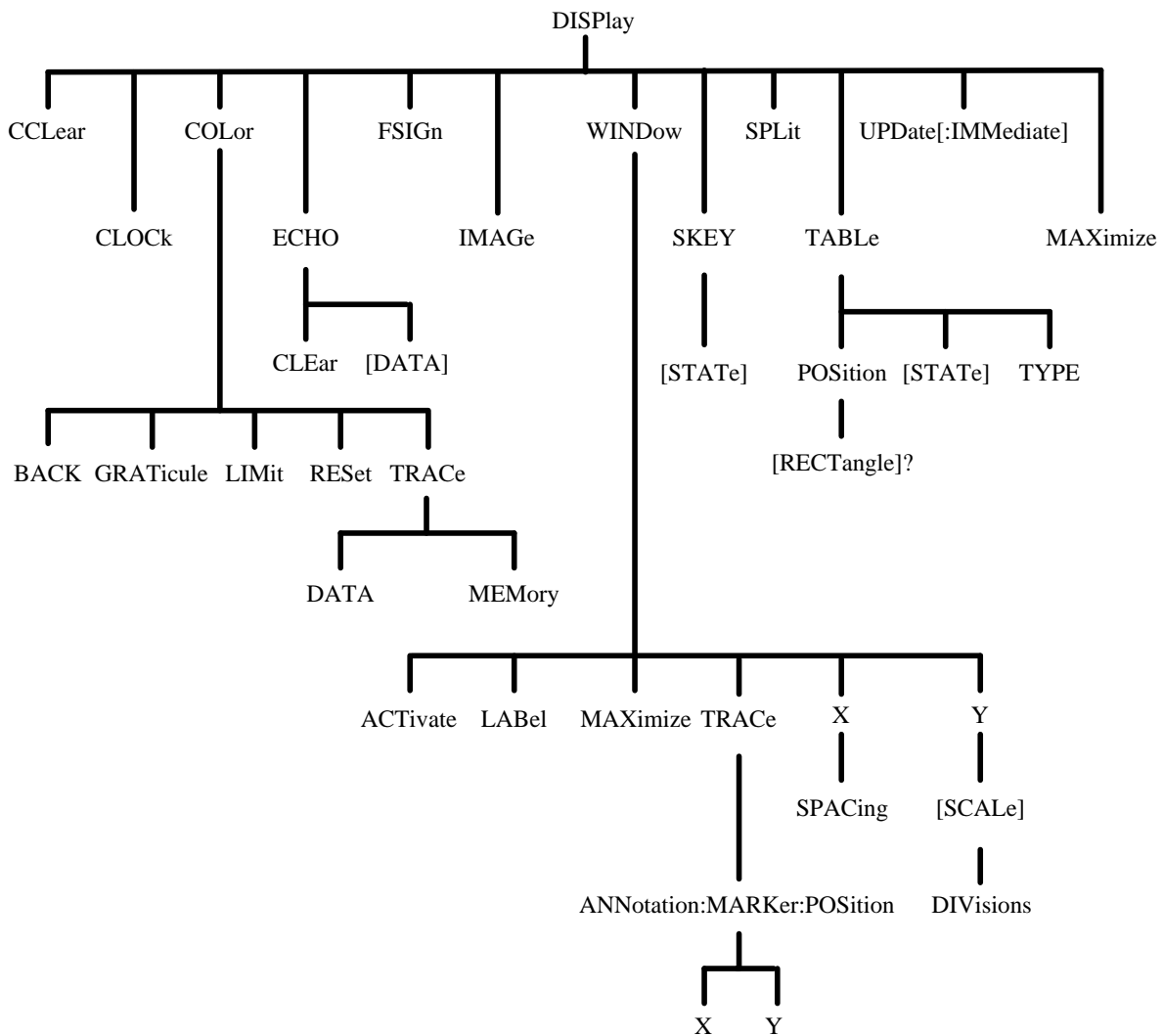

DISPlay:CCLear

(Read-Write) Clear the error message displayed in the status bar (at the lower right corner of the LCD displayer). To display/hide the task bar, use the command DISPlay:ANNOtation:STATus <ON|OFF>.

Example

```
:DISP:CCL
display:cclear
```

Query Syntax

NONE

Overlapping? No

Default NONE

DISPlay:CLOCK <ON|OFF>

(Read-Write) Turn on/off clock display (upper right corner of the LCD displayer).

Parameter

<ON|OFF> ON - Turn on clock display.
OFF - Turn off clock display.

Example `DISP:CLOC ON`

Query `DISPlay:CLOCK?`
Syntax
Return Type Boolean (ON - Display OFF - Hide)

Overlapping? No

Default ON

DISPlay:COLor<dnum>:BACK <num1>,<num2>,<num3>

(Read-Write) Set /get screen background color.

Parameter

<dnum> 1 or 2 may be selected
1: Standard display
<num1>, 2: Inversion display
<num2>, Note: To set standard display and inversion display, use the command DISPlay:IMAGe
<num3> <NORMal|INVert>. Default to standard display.
Integer, optionally from 0 to 5, respectively representing the components of red, green, and blue.

Example `DISP:COLor2:BACK 5,5,5 // Set the background color under inversion display to pure white.`
`display:color:back 0,0,3`

Query `DISPlay:COLor<dnum>:BACK?`
Syntax
Return Type Char1,Char2,Char3

Overlapping? No

Default 0,0,0

DISPlay:COLor<dnum>:GRATicule<gnum> <num1>,<num2>,<num3>

(Read-Write) This command can set/get:

1. Color marked by grid.
2. Outer edge line of Figure <gnum:1>.
3. Grid line color of Figure <gnum:2>.

Parameter

1 or 2 may be selected
 1: Standard display
 2: Inversion display
 Note: To set standard display and inversion display, use the command DISPLAY:IMAGe <NORMal|INVert>. Default to standard display.
 It can choose 1 or 2
 1: Outer edge line color
 2: Grid line color
 Integer, optionally from 0 to 5, respectively representing the components of red, green, and blue.

Example

```
DISP:COLor:GRAT1 3,3,3 //Set the outer edge line color under standard display status.
display:color:graticule2 1,1,1 //Set the grid line color under standard display status.
```

Query
 Syntax
 Return Type

DISP:COLor<dnum>:GRATicule<gnum>?
 Char1,Char2,Char3

Overlapping? No

Default 0,0,0

DISP:COLor<dnum>:LIMit<Inum> <num1>,<num2>,<num3>

(Read-Write) This command can set/get:

1. Display color for the failed limit test results, bandwidth test results and wave test results (Inum: 1).
2. Limit color for the limit test results, bandwidth test results and wave test results (Inum: 2).

Parameter

1 or 2 may be selected
 1: Standard display
 2: Inversion display
 Note: To set standard display and inversion display, use the command DISPLAY:IMAGe <NORMal|INVert>. Default to standard display.
 It can choose 1 or 2
 1: Word FAIL (FAIL) color, test failure point color.
 2: Limit line color
 Integer, optionally from 0 to 5, respectively representing the components of red, green, and blue.

Example

```
DISP:COLor:LIM 5,0,0 // Set the FAIL mark under standard display status to pure red.
display:color2:limit2 5,0,0
```

Query
 Syntax
 Return Type

DISP:COLor<dnum>:LIMit<Inum>?
 Char1,Char2,Char3

Overlapping? No

Default 0,0,0

DISPlay:COLor<dnum>:RESet

(Write only) Reset the display color of all items to the factory default state.

Parameter

1 or 2 may be selected
 1: Standard display
 <dnum> 2: Inversion display
 Note: To set standard display and inversion display, use the command DISPlay:IMAGe <NORMal|INVert>. Default to standard display.

Example

```
DISP:COLor2:RESet //Set to reset all item colors under inversion display status.
display:color:reset
```

Query
Syntax

NONE

Overlapping? No

Default NONE

DISPlay:COLor<dnum>:TRACe<tr>:DATA <num1>,<num2>,<num3>

(Read-Write) Set/get the color of specified trace <tr>.

Parameter

1 or 2 may be selected
 1: Standard display
 <dnum> 2: Inversion display
 <tr> Note: To set standard display and inversion display, use the command DISPlay:IMAGe <NORMal|INVert>. Default to standard display.
 <num1>,<num2>,<num3> Trace number. Integer, with the range of 1 to 8.
 Integer, optionally from 0 to 5, respectively representing the components of red, green, and blue.

Example

```
DISP:COLor:TRAC2:DATA 0,5,5 // Set the color of Trace 2 under standard display status.
display:color2:trace1:data 0,0,3
```

Query
Syntax
Return Type

DISPlay:COLor<dnum>:TRACe<tr>:DATA?
Char1,Char2,Char3

Overlapping? No

Default 0,0,0

DISPlay:COLor<dnum>:TRACe<tr>:MEMory <num1>,<num2>,<num3>

(Read-Write) Set/get the color of the specified memory trace <tr>.

Parameter

	1 or 2 may be selected
<dnum>	1: Standard display
<tr>	2: Inversion display
<num1>, <num2>, <num3>	Note: To set standard display and inversion display, use the command DISPlay:IMAGe <NORMal INVert>. Default to standard display. Trace number. Integer, with the range of 1 to 8. Integer, optionally from 0 to 5, respectively representing the components of red, green, and blue.

Example

```
DISP:COLor2:TRAC3:MEM 2,2,2 // Set the color of memory trace of Trace 3 under inversion display status.
display:color:trace1:memory 0,0,3
```

Query Syntax	DISPlay:COLor<dnum>:TRACe<tr>:MEMory?
Return Type	Char1,Char2,Char3

Overlapping? No

Default 0,0,0

DISPlay:ECHO:CLEAr

(Write only) Clear all contents displayed in the ECHO window.

Example `DISPlay:ECHO:CLEAr`

Query Syntax NONE

Overlapping? No

Default NONE

DISPlay:ECHO[:DATA] <string>

(Write only) Display the string in the ECHO window.

Note: Use DISP:TABL:TYPE ECHO and DISP:TABL:STAT ON commands to Turn on the ECHO window.

Parameter

<string> Strings to be displayed in the echo window. 254 strings at maximum.

Example `DISP:ECHO "Test Result"`
`display:echo:data "echo data"`

Query Syntax NONE

Overlapping? No

Default NONE

DISPlay:FSIGN <ON|OFF>

(Read-Write) Turn on/off the "failed (FAIL)" display of the LCD displayer when limit test, bandwidth test and wave test fail.

Parameter

<ON|OFF> ON - "FAIL" display enabled
OFF - "FAIL" display disabled

Example `DISP:FSIG ON`
`display:fsign off`

Query Syntax `DISPlay:FSIGN?`
Return Type Boolean (ON - Display, OFF - Non-display)

Overlapping? No

Default ON

DISPlay:IMAGe <NORMal|INVert>

(Read-Write) Set/get the display type of LCD displayer.

Parameter

<NORMal|INVert> NORMAL - Specify the standard display mode.
 Vert> INVert - Specify the inversion (reverse) display mode.

Example

```
DISP:IMAG INV
display:image normal
```

Query DISPlay:IMAGe?
 Syntax Char
 Return Type

Overlapping? No

Default NORMal

DISPlay:MAXimize <ON|OFF>

(Read-Write) Turn on/off the zoom extent of the current window.

Parameter

<ON|OFF> ON - Turn on the zoom extent of the window.
 OFF - Turn off the zoom extent of the window.

Example

```
DISP:MAX ON
display:maximize off
```

Query DISPlay:MAXimize?
 Syntax Boolean (ON - Turn on, OFF - Turn off)
 Return Type

Overlapping? No

Default OFF

DISPlay:SKEY[:STATe] <ON|OFF>

(Read-Write) Display/hide the side key menu.

Parameter

<ON|OFF> ON - Display the side key menu bar.
OFF - Hide the side key menu bar.

Example

```
DISP:SKEY ON
display:skey:state off
```

Query
Syntax

DISPlay:SKEY[:STATe]?

Return Type

Boolean (ON - Turn on, OFF - Turn off)

Overlapping? No

Default ON

DISPlay:SPLit <char>

(Read-Write) Window layout.

Parameter

<char> See Window Layout Mode.

Example

```
DISP:SPL D1_1_2
display:split D11_23
```

Query
Syntax

DISPlay:SPLit?

Return Type

Char

Overlapping? No

Default D1

DISPlay:TABLE:POSition[:RECTangle]?

(Read only) Read the display coordinate position ([0, 0] on upper left corner of the display) of the table area. If DISPlay:TABLE:STATe is off, it returns 0,0,0,0.

Example

```
DISP:TABLE:POS?
display:table:position:rectangle?
```

Query
Syntax

DISPlay:TABLE:POSition[:RECTangle]?

Return Type

Return num1,num2,num3,num4

num1: position of Coordinate X on the upper left corner of the table area.

num2: position of Coordinate Y on the upper left corner of the table area.
 num3: position of Coordinate X on the upper right corner of the table area.
 num4: position of Coordinate Y on the upper right corner of the table area.

Overlapping? No

Default NONE

DISPlay:TABLE[:STATe] <ON|OFF>

(Read-Write) Turn on/off table display. The specified display content is determined by DISPlay:TABLE:TYPE.

Note: To display table, it can still use command, DISP:WIND:TABL.

Parameter

<ON|OFF> ON - Display table (on the lower window).
 OFF - Hide table.

Example

```
DISP:TABL ON
display:table:state off
```

Query

Syntax

Return Type

DISPlay:TABLE[:STATe]?
 Boolean (ON - Display, OFF - Hide)

Overlapping? No

Default OFF

DISPlay:TABLE:TYPE <char>

(Read-Write) Set/read the display table type (lower window of the LCD). Use DISPlay:TABLE:STATe to display the table.

Note: To display table, it can still use command, DISP:WIND:TABL.

Parameter

Select form the following items:

“MARKer”: specify the marked table window.

“LIMit”: specify the limit test table window.

“SEGment”: specify the segment table window.

“ECHO”: specify the echo window. (Not supported)

“PLOSs”: specify the loss assumption table window. (Not supported)

“SCFactor”: specify the power sensor calibration factor table window. (Not supported)

“RLIMit”: specify the wave test table window.

<char>

Example

```
DISP:TABL:TYPE MARK
```

```
display:table:type marker
```

Query Syntax DISPLAY:TABLE:TYPE?
Return Type Char

Overlapping? No

Default MARKer

DISPlay:UPDate[:IMMEDIATE]

(Write only) When it displays Update Off (set by DISP:ENAB OFF), this command immediately performs a primary display update.

Example

```
DISP:UPD  
display:update:immediate
```

Query Syntax NONE

Overlapping? No

Default NONE

DISPlay:WINDow<wnum>:ACTivate

(Write only) Activate the specified window.

Parameter

<wnum> Window index. Integer, with the range of 1 to 32. Default to 1.

Example

```
DISP:WIND2:ACT  
display>window:active
```

Query Syntax NONE

Overlapping? No

Default NONE

DISPlay:WINDow<wnum>:LABel <ON|OFF>

(Read-Write) Turn on/off the grid label display of the specified window <wnum>.

Parameter

<wnum> Window index. Integer, with the range of 1 to 32. Default to 1.

<ON|OFF> ON - Display grid label.
OFF - Hide grid label.

Example

```
DISP:WIND1:LAB ON
display:window2:label off
```

Query Syntax DISPlay:WINDow<wnum>:LABel?
Return Type Boolean (ON - Display, OFF - Hide)

Overlapping? No

Default ON

DISPlay:WINDow<wnum>:MAXimize <ON|OFF>

(Read-Write) Specify the zoom extent of active trace in the window <wnum>.

Parameter

<wnum> Window index. Integer, with the range of 1 to 32. Default to 1.

<ON|OFF> ON - Turn on zoom extent.
OFF - Turn off zoom extent.

Example

```
DISP:WIND1:MAX ON
display:window2:maximize off
```

Query Syntax DISPlay:WINDow<wnum>:MAXimize?
Return Type Boolean

Overlapping? No

Default OFF

DISPlay:WINDow<wnum>:TRACe<tr>:ANNotation:MARKer:POSition:X <num>

(Read-Write) Set or read the Coordinate X position of the position displayed by the mark value.

Parameter

<wnum> Ignore this parameter

<tr> Ignore this parameter

<num> Display position of mark value on X-axis. It shows the percentage value scale of the current position X-axis coordinate to the entire X-axis, double-precision floating-point type. -15 to 100%.

Example

```
DISP:WIND:TRAC:ANN:MARK:POS:X 10
display>window:trace:annotation:marker:position:x 33
```

Query
Syntax
Return Type

```
DISPlay:WINDow<wnum>:TRACe<tr>:ANNotation:MARKer:POSition:X?
Char
```

Overlapping? No

Default NONE

DISPlay:WINDow<wnum>:TRACe<tr>:ANNotation:MARKer:POSition:Y <num>

(Read-Write) Set or read the Coordinate Y position of the position displayed by the mark value.

Parameter

<wnum> Ignore this parameter

<tr> Ignore this parameter

<num> Display position of mark value on Y-axis. It shows the percentage value scale of the current position Y-axis coordinate to the entire Y-axis, double-precision floating-point type. -15 to 100%.

Example

```
DISP:WIND:TRAC:ANN:MARK:POS:Y 10
display>window:trace:annotation:marker:position:y 33
```

Query
Syntax
Return Type

```
DISPlay:WINDow<wnum>:TRACe<tr>:ANNotation:MARKer:POSition:Y?
Char
```

Overlapping? No

Default NONE

DISPlay:WINDow<wnum>:X:SPACing <char>

(Read-Write) Targeting on the traces in the channels with segment sweep in the specified window <Wnum>, X-axis display type is set.

Parameter

<wnum> Ignore this parameter

<char> Select from the following items

LINear - Measurement points on X-axis are arranged in order of frequency.
OBASe - Measurement points on X-axis are arranged in order of measurement sequence.

Example `DISP:WIND:X:SPAC OBAS`
 `display:window:x:spacing linear`

Query Syntax `DISPlay:WINDow<wnum>:X:SPACing?`
 Return Type Char

Overlapping? No

Default LINear

DISPlay:WINDow<wnum>:Y[:SCALe]:DIVisions <num>

(Read-Write) Set/get the grid numbers displayed on Y-axis.

Parameter

<wnum> Ignore this parameter

<num> Grid number of figure. Integer, with the range of 4 to 30.

Example `DISP:WIND:Y:DIV 12`
 `display:window2:y:scale:divisions 20`

Query Syntax `DISPlay:WINDow<wnum>:Y[:SCALe]:DIVisions?`
 Return Type Char

Overlapping? No

Default 10

Format Commands

The transmission method used when transmitting large amounts of data.

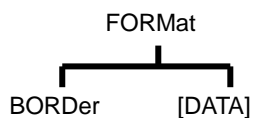

They will be affected when transmitting data with the following commands:

1. `CALC:DATA`
2. `CALC:RDATA`
3. `CALC:DATA:FDAT`
4. `CALC:DATA:FMEM`
5. `CALC:DATA:SDAT`

-
6. CALC:DATA:SMEM
 7. CALC:FUNC:DATA?
 8. CALC:LIM:DATA
 9. CALC:LIM:REP?
 10. CALC:LIM:REP:ALL?
 11. CALC:BLIM:REP?
 12. CALC:RLIM:DATA
 13. CALC:RLIM:REP?
 14. SENS:FREQ:DATA?
 15. SENS:X:VAL?
 16. SENS:SEGM:DATA
 17. SOUR:POW:PORT:CORR:COLL:TABL:ASEN:DATA
 18. SOUR:POW:PORT:CORR:COLL:TABL:BSEN:DATA
 19. SOUR:POW:PORT:CORR:COLL:TABL:LOSS:DATA
 20. SOUR:POW:PORT:CORR:DATA
-

FORMat:BORDer <char>

(Read-Write) Set the sequence of bytes during GPIB data transmission. Some computers read data from the analyzer in the reverse order. Only when FORMAT:DATA is set to REAL will the command be valid; when FORMAT:DATA is set to ASCLL, this command is invalid.

Parameter

<char> Options:
 NORMal - All IPCs except IBM compatible computers
 SWAPped - IBM compatible computers

Example

```
FORM:BORD SWAP
format:border normal
```

Query Syntax FORMat:BORDer?

Overlapping? No

Default Normal

FORMat[:DATA] <char>

(Read-Write) Set the data format during data transmission. Transmitting measurement data using command CALC:DATA.

Transmitting source power calibration data using commands
 SOURce:POWeR:CORRection:COLLect:TABLe:DATA,
 SOURce:POWeR:CORRection:COLLect:TABLe:FREQuency and SOURce:POWeR:CORRection:DATA.

Parameter

Options:

Version 1.2.0 and above.

ASCIi - Specifies the ASCII transport format, same as ASCII, 0.

REAL - Specifies the IEEE 64-bit float binary transmission format, same as REAL, 64.

REAL32 - Specifies the IEEE 32-bit float binary transmission format, same as REAL, 32.

Other versions.

<char>

REAL, 32 - (Default for REAL format) The best way to transfer large amounts of measurement data.

REAL, 64 - Slow transmission, but are more valid bits than the REAL, 32 format. REAL, 32 format can be used if the user's computer does not support REAL64.

ASCIi, 0 - Simple to implement, but very slow. Generally used to transfer a small amount of data.

For more information, see data obtained from the analyzer.

Example

```
Version 1.2.0 and above
FORM ASC
format:data ascii
Other versions
FORM REAL,64
format:data ascii
```

Query Syntax FORMat:DATA?

Return Type Character (1.2.0 and above) or Character,Character (other versions)

Overlapping? No

Default ASCII

Hardcopy Commands

HCOPY[:IMMediate]

(Write only) Print screen.

Example

```
HCOP
hcopy:immediate
```

Query Syntax NONE

Overlapping? No

Default NONE

Initiate Command

Control the trigger signal.

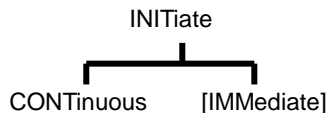

INITiate:CONTInuous <boolean>

(Read-Write) Set the analyzer to continuous trigger mode or manual trigger mode.

Parameter

<boolean> ON (or 1) - Continuous trigger mode.
 OFF (or 0) - Manual trigger mode.

Example `INIT:CONT ON initiate:continuous off`

Query Syntax `INITiate:CONTInuous?`

Return Type Bool (1 = ON, 0 = OFF)

Overlapping? No

Default ON

INITiate<cnun>[:IMMEDIATE]

(Write only) End the current sweep and immediately send a trigger signal to the specified channel. (Function is same with Sweep\Trigger\Restart of the front panel).

If the specified channel is on hold mode, then it enters hold mode after primary sweep.

If Trigger:Scope=Global, all channels will receive the trigger signal.

If Trigger:Scope=Channel, only the active channel receives the trigger signal, and if the specified channels are not active, it will not receive a trigger signal.

If the specified channel is not in manual trigger mode (INIT:CONT OFF), the analyzer returns an error message.

If the channel <cnun> does not exist, the analyzer returns an error message.

Parameter

<cnun> Any existing channel number; if unspecified, set to 1.

Example `INIT initiate2:immediate`

Query Syntax NONE

Overlapping? Yes

Default NONE

Memory Command

Store or recall the instrument status.

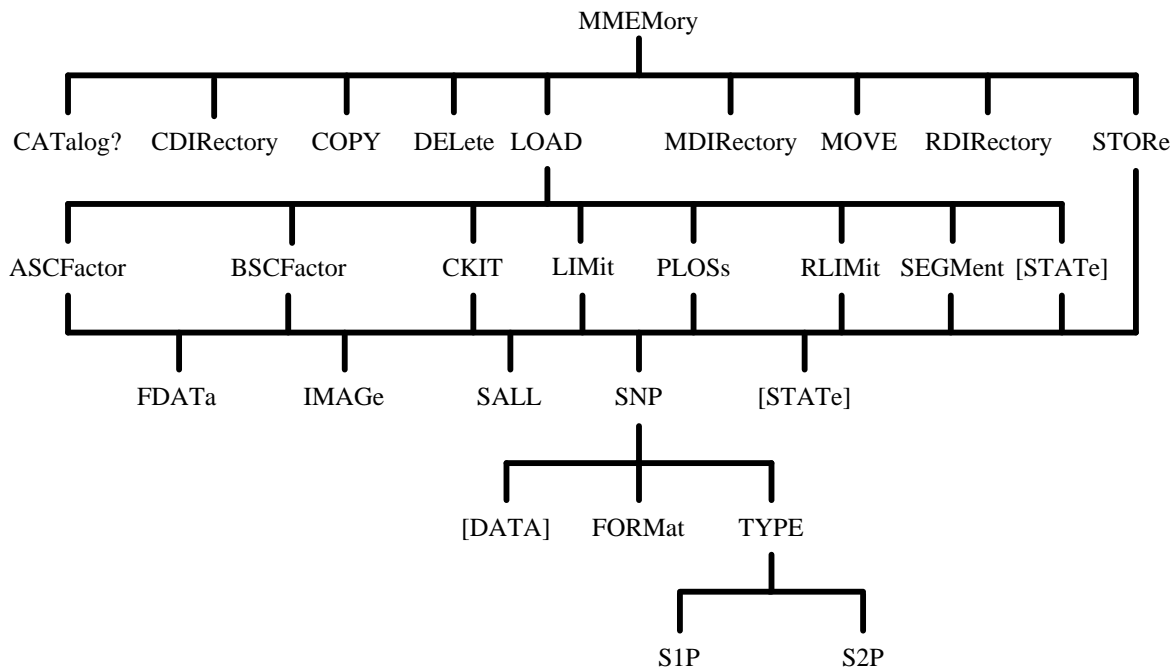

MMEM files have other extension determined by their types:

.sta - Instrument status

.cal - Calibration file

.cst - Instrument status and calibration file

The default folder is: "C:\Program Files\3656X Vector Network Analyzer \MemoryDocuments"

It can change the current path by using MMEMory:CDIRectory command, or specify the location of MMEM file and folder by using absolute path.

MMEMory:CATalog[:<char>]? [<folder>]

(Read only) Return the file name list (separated by commas) of specified type under the specified folders. If unspecified, it will return "The specified file format is invalid."

Parameter

File type. Options:

STATe - Instrument calibration data file (.sta)

<char> CORRection - Calibration data file (.cal)

CState - Instrument state and calibration data (.cst)

If unspecified, it will list the files of all types.

<folder> String - Any existing folder name. if unspecified, default to "C:\Program Files\AV3656A Vector Network Analyzer \Memory Documents".

Example

```
MMEM:CAT? 'List all files under the current folder.
mmemory:catalog:correction? 'C:\Program Files\3656X Vector Network
```

Analyzer\\MemoryDocuments' 'List .cal files in a specified folder\\MemoryDocuments'
 'List .cal files in a specified folder.'

Overlapping? No

Default NONE

MMEMory:CDIRectory <folder>

(Read-Write) Change the path.

Parameter

Any existing driver and folder name.

If under the directory "C:\Program Files\AV3656A Vector Network Analyzer \Memory Documents", directly input it.

MMEM:CDIR 'Service'

<folder> If the new folder is not under the first-level directory "C:\Program Files\AV3656B Vector Network Analyzer \Memory Documents", it should add (\\) before the file name.

mmemory:cdirectory "\\automation" "Set default path to the next sub-directory.

Specify the location of new folder by absolute path.

mmemory:cdirectory 'c:\\automation\\service'

Query Syntax MMEMory:CDIRectory? Return to the current directory

Return Type String

Overlapping? No

Default 'C:\Program Files\AV3656A Vector Network Analyzer \MemoryDocuments'

MMEMory:COPY <file1>,<file2>

(Write only) When copy File 1 to File 2, it must specify an extension.

Parameter

<file1> String - File name to be copied.

<file2> String - File name to be created.

Example MMEM:COPY 'MyFile.cst','YourFile.cst'

Query Syntax NONE

Overlapping? No

Default NONE

MMEMory:DELeTe <file>

(Write only) When delete a file, it must specify an extension.

Parameter

<file> String - File name to be deleted.

Example `MMEM:DEL 'MyFile.cst'`

Query Syntax NONE

Overlapping? No

Default NONE

MMEMory:LOAD[:<char>] <file>

(Write only) Load the specified file.

Parameter

<char> The file types to be loaded. Options:
 STAtE - Instrument calibration data file (.sta)
 CORRection - Calibration data file (.cal)
 CSTate - Instrument state and calibration data (.cst)
 If <char> parameters are unspecified, the file name must contain an extension.
 If the extension specified in <file> is inconsistent with <char>, it performs no action.

<file> String - File name to be loaded. If <file> contains no specified folder, use default folder.

Example `MMEM:LOAD 'MyFile.cst' mmemory:load:state 'MyInstState'`

Query Syntax NONE

Overlapping? No

Default NONE

MMEMory:MDIRectory <folder>

(Write only) Create new file folder.

Parameter

<folder> String - Name of new folder.

Example `MMEM:MDIR 'MyFolder' mmemory:mdirectory 'c:\\NewFolder'`

Query Syntax NONE

Overlapping? No

Default NONE

MMEMory:MOVE <file1>,<file2>

(Write only) Rename <file1> to <file2>. A file extension must be specified.

Parameter

<file1> String - File name to be renamed.

<file2> String - New file name.

Example `MMEM:MOVE 'MyFile.cst','YourFile.cst'`

Query Syntax NONE

Overlapping? No

Default NONE

MMEMory:RDIRectory <folder>

(Write only) Delete the specified folder.

Parameter

<folder> String - Folder name to be deleted.

Example `MMEM:RDIR 'MyFolder'`

Query Syntax NONE

Overlapping? No

Default NONE

MMEMory:STORe[:<char>] <file>

(Write only) Store the specified file (.sta, .cal, .cst).

Parameter

	The file types to be stored. Options:
	STATe - Instrument calibration data file (.sta)
	CORRection - Calibration data file (.cal)
<char>	CSTate - Instrument state and calibration data(.cst)
	If <char> parameters are unspecified, the file name must contain an extension.
	If the extension specified in <file> is inconsistent with <char>, it prompts "File extension inconsistent".
<file>	String - Any valid file name.

Example

```
MMEM:STOR:STAT 'myState'
mmemory:store 'c:\\bin\\myState.sta'
```

Query Syntax NONE

Overlapping? No

Default NONE

MMEMory:CATalog <string>

(Read only) Read the name and size of all files (including directories) under space occupation, available space and specified directory of memory device of AV3656A analyzer.

Parameter

<string> Directory name of message to be read out

Example

```
MMEM:CAT?'d:\'
mmemory:catalog?'d:\'
```

Query Syntax NONE
 Return Type Directory message ("A, B, Name 1, Size 1, Name 2, Size 2, Name N, Size N")
 N: number of all files in the directory.
 A: space occupation of internal memory device (byte).
 B: space available of internal memory device (byte).

Overlapping? No

Default NONE

MMEMory:COPIY <file1>,<file2>

(Write only) Used to copy the specified file.

Parameter

<file1>,<file2> String - 2 file names (original file name to be copied, objective file name to be copied)

Example

```
MMEM:COPY "test/state01.sta","d:test01.sta"
mmemory:copy "test/state01.sta","d:test01.sta"
```

Query Syntax NONE

Overlapping? No

Default NONE

MMEMory:DELeTe <file>

(Write only) Delete the specified file and directory.

Parameter

<file> String - File name or directory name to be deleted

Example

```
MMEMory:DELeTe "test/state01.sta"
mmemory:delete "D:\\test"
```

Query Syntax NONE

Overlapping? No

Default NONE

MMEMory:LOAD:ASCFactor <file>

(Write only) Recall the file (.csv) specified as a referential calibration factor table and power sensor A calibration factor table.

Parameter

<file> String - File name (.csv) of reference calibration factor and power sensor A calibration factor table.

Example

```
MMEM:LOAD:ASCF "d:\sensor01.csv"
mmemory:load:ascfactor "d:\sensor01.csv"
```

Query Syntax NONE

Overlapping? No

Default NONE

MMEMory:LOAD:BSCFactor <file>

(Write only) Recall the file (.csv) specified as a referential calibration factor table and power sensor B calibration factor table.

Parameter

<file> String - File name (.csv) of reference calibration factor and power sensor B calibration factor table.

Example `MMEM:LOAD:BSCF "d:\sensor01.csv" mmemory:load:bscfactor "d:\sensor01.csv"`

Query Syntax NONE

Overlapping? No

Default NONE

MMEMory:LOAD:CKIT<Ckit> <file>

(Write only) Recall the instrument state of a single channel from the specified register

Parameter

<Ckit> Number of calibration kit. From 1 to 20

<file> String - File name of calibration kit definition table

Example `MMEM:LOAD:CKIT1 "Test1/Ckit01.ckx" mmemory:load:ckit2 "Test1/Ckit01.ckx"`

Query Syntax NONE

Overlapping? No

Default 1

MMEMory:LOAD:LIMit <file>

(Write only) From the specified limit table file from limit table of the active trace in active channels

Parameter

<file> String - File name of limit table (.csv)

Example `MMEM:LOAD:LIM "test/limit01.csv"`
`mmemory:load:limit "test/limit01.csv"`

Query Syntax NONE

Overlapping? No

Default NONE

MMEMory:LOAD:PLOSs<pt> <file>

(Write only) Recall the specified loss compensation table file, to be used as the loss compensation table for active channel and selected port.

Parameter

<pt> Port number

<file> String - File name of loss compensation table (.csv)

Example `MMEM:LOAD:PLOS "test/loss01.csv" mmemory:load:ploss2 "test/loss01.csv"`

Query Syntax NONE

Overlapping? No

Default NONE

MMEMory:LOAD:RLIMit <file>

(Write only) Recall the specified fluctuation limit table file of the active channel

Parameter

<file> String - File name of fluctuation limit table (.csv)

Example `MMEM:LOAD:RLIM "test/Rlimit01.csv" mmemory:load:rlimit "test/Rlimit01.csv"`

Query Syntax NONE

Overlapping? No

Default NONE

MMEMory:LOAD:SEGMENT <file>

(Write only) Recall the specified segment sweep list file

Parameter

<file> String - File name of segment sweep list (.csv)

Example `MMEM:LOAD:SEGM "d:\segm01.csv" mmemory:load:segment "d:\segm01.csv"`

Query Syntax NONE

Overlapping? No

Default NONE

MMEMory:LOAD[:STATe] <file>

(Write only) Recall the specified instrument state file

Parameter

<file> String - File name of instrument state (.sta)

Example `MMEM:LOAD "d:\state01.sta" mmemory:load:state "d:\state01.sta"`

Query Syntax NONE

Overlapping? No

Default NONE

MMEMory:STORe:ASCFactor <file>

(Write only) Store the reference calibration factor and calibration factor table of power sensor A to the specified file

Parameter

<file> String - File name of reference calibration factor and calibration factor table of power sensor A stored (.csv).

Example `MMEM:STOR:ASCF "d:\sensor01.csv" mmemory:store:ascfactor "d:\sensor01.csv"`

Query Syntax NONE

Overlapping? No

Default NONE

MMEMory:STORe:BSCFactor <file>

(Write only) Store the reference calibration factor and calibration factor table of power sensor B to the specified file

Parameter

<file> String - File name of reference calibration factor and calibration factor table of power sensor B stored (.csv).

Example `MMEM:STOR:BSCF "d:\sensor01.csv" mmemory:store:bscfactor "d:\sensor01.csv"`

Query Syntax NONE

Overlapping? No

Default NONE

MMEMory:STORe:CKIT<Ckit> <file>

(Write only) Store the calibration kit definition table to the file

Parameter

<Ckit> Number of calibration kit. From 1 to 20

<file> String - File name of calibration kit definition table stored

Example `MMEM:STOR:CKIT2 "Test1/Ckit01.csv" mmemory:store:ckit "Test1/Ckit01.ckx"`

Query Syntax NONE

Overlapping? No

Default 1

MMEMory:STORe:FDATA <file>

(Write only) Store the formative data array to CSV file

Parameter

<file> String - File name of formative data array stored (.csv)

Example `MMEM:STOR:FDAT "d:\trace01.csv" mmemory:store:fdata "d:\trace01.csv"`

Query Syntax NONE

Overlapping? No

Default NONE

MMEMory:STORe:IMAGe <file>

(Write only) Store the display image on the LCD screen to the file of bitmap format (.bmp) or portable network graphics format (.png).

Parameter

<file> String - File name of objective file (.bmp or .png)

Example `MMEM:STOR:IMAG "d:image01.bmp" mmemory:store:image "test/image01.png"`

Query Syntax NONE

Overlapping? No

Default NONE

MMEMory:STORe:LIMit <file>

(Write only) Store the limit table of active traces in active channel to the specified format file.

Parameter

<file> String - File name of limit table stored (.csv)

Example `MMEM:STOR:LIM "test/limit01.csv" mmemory:store:limit "test/limit01.csv"`

Query Syntax NONE

Overlapping? No

Default NONE

MMEMory:STORe:PLOSs<pt> <file>

(Write only) Store the loss compensation table in active channel to the specified format file.

Parameter

<pt> Port number
 <file> String - File name of loss compensation table stored (.csv)

Example `MMEM:STOR:PLOS1 "test/loss01.csv" mmemory:store:ploss "test/loss01.csv"`

Query Syntax NONE

Overlapping? No

Default NONE

MMEMory:STORe:RLIMit <file>

(Write only) Store the fluctuation limit list table of active traces in active channel to the specified format file.

Parameter

<file> String - File name of fluctuation limit table stored (.csv)

Example `MMEM:STOR:RLIM "test/Rlimit01.csv" mmemory:store:rlimit "test/Rlimit01.csv"`

Query Syntax NONE

Overlapping? No

Default NONE

MMEMory:STORe:SALL <ON|OFF>

(Read-Write) Set/get the settings to store all channel/trace, or only store the displayed channel/trace.

Parameter

<ON|OFF> Select the content to be stored which used for setting instrument status.
 ON: save all traces.
 OFF: save a single trace.

Example `MMEM:STOR:SALL ON mmemory:store:sall off`

Query Syntax MMEMory:STORe:SALL?

Overlapping? No

Default OFF

MMEMory:STORe:SEGMENT <file>

(Write only) Store the segment sweep table of active channel to the specified format file.

Parameter

<file> String - File name of segment sweep list stored (.csv)

Example `MMEM:STOR:SEGM "d:\segm01.csv" mmemory:store:segment "d:\segm01.csv"`

Query Syntax NONE

Overlapping? No

Default NONE

MMEMory:STORe:SNP[:DATA] <file>

(Write only) Store the measurement data of active channel to the standard format file.

Parameter

<file> String - File name and extension (s1p when specify 1 port, s2p when specify 2 ports, s3p when specify 3 ports and s4p when specify 4 ports) to be used when storing the standard format file

Example `MMEM:STOR:SNP "SNP01.s3p" mmemory:store:snp:data "SNP01.s3p"`

Query Syntax NONE

Overlapping? No

Default NONE

MMEMory:STORe:SNP:FORMat <char>

(Read-Write) Set/get the data format

Parameter

<char> Standard file format.
 "AUTO": automatically specify the data format according to the display format of active traces.

“MA”: specify the data format “log amplitude > angle”.
 “DB”: specify the data format “linear amplitude > angle”.
 “RI”: specify the data format “real part > imaginary part”.

Example

```
MMEM:STOR:SNP:FORM MA
mmemory:store:snp:format DB
```

Query Syntax MMEMory:STORe:SNP:FORMat?

Overlapping? No

Default “AUTO”

MMEMory:STORe:SNP:TYPE:S1P <num>

(Read-Write) When storing s1p data file, set/get the specified port.

Parameter

<num> Port number: 1

Example

```
MMEM:STOR:SNP:TYPE:S1P 2
```

Query Syntax MMEMory:STORe:SNP:TYPE:S1P?

Return Type Char

Overlapping? No

Default 1

MMEMory:STORe:SNP:TYPE:S2P <num1>,<num2>

(Read-Write) When storing s2p data file, set/get the specified port (2-ports).

Parameter

<num1>,<num2> Specify 2-element array data (port number). num1: specify a port for file type. num2: specify the other ports for file type. Array index starts from 0. Range: 1 to 2

Example

```
MMEM:STOR:SNP:TYPE:S2P 1,2
```

Query Syntax MMEMory:STORe:SNP:TYPE:S2P ?

Return Type Char,Char

Overlapping? No

Default 1

MMEMory:STORe[:STATe] <file>

(Write only) Store instrument state to the file.

Parameter

<file> String - File name of instrument state stored (.sta)

Example `MMEM:STOR "d:\state01.sta" mmemory:store:state "d:\state01.sta"`

Query Syntax NONE

Overlapping? No

Default NONE

MMEMory:STORe:STYPe <char> <Not Achievable Temporarily>

(Read-Write) When store the instrument state to the file, select the content to be stored.

Parameter

Instrument state data
 "STATe": specify only store the measurement condition.
 "CSTate": specify store the measurement condition and calibration state.
 "DSTate": specify store the measurement condition and formative data array.
 "CDSTate": specify store the measurement condition, calibration data and formative data array.

Example `MMEMory:STORe:STYPe CDST`

Query Syntax `MMEMory:STORe:STYPe?`

Return Type Char

Overlapping? No

Default "CSTate"

Output Commands

OUTPut[:STATe] <ON | OFF>

(Read-Write) Turn on or off RF source power output.

Parameter

<ON | OFF> ON (or 1) - Turn on RF source.
OFF (or 0) - Turn off RF source.

Example `OUTP ON`
`output:state off`

Query Syntax `OUTPut[:STATe]?`

Return Type Bool (1 = ON, 0 = OFF)

Overlapping? No

Default ON

Sens:Average Commands

Set sweep averaging parameter. Averaging is a noise reduction technique that averages n sweeps for each data point (n = customized times of averaging). Averaging works on all measurements in this channel.

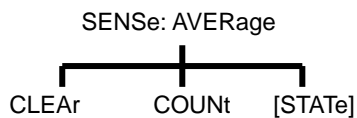

View the Applications of these commands Example.

SENSe<cnum>:AVERage:CLEAr

(Write only) Clear and restart the averaging of the measurement data.

Parameter

<cnum> Any existing channel number; if unspecified, set to 1.

Example `SENS:AVER:CLE`
`sense2:average:clear`

Query Syntax NONE

Overlapping? No

Default NONE

SENSe<cnum>:AVERage:COUNT <num>

(Read-Write) Set the averaging times of measurement.

Parameter

<cnum> Any existing channel number; if unspecified, set to 1.

<num> Averaging times. Value range: 1 to 1024.

Example

```
SENS:AVER:COUN 999
sense2:average:count 73
```

Query Syntax SENSE<cnum>:AVERage:COUNT?

Return Type Char

Overlapping? No

Default 1

SENSe<cnum>:AVERage[:STATe] <ON | OFF>

(Read-Write) Turn on or off the track averaging function.

Parameter

<cnum> Any existing channel number; if unspecified, set to 1.

<ON | OFF> ON (or 1) - Turn on averaging.
OFF (or 0) - Turn off averaging.

Example

```
SENS:AVER ON
sense2:average:state off
```

Query Syntax SENSE<cnum>:AVERage[:STATe]?

Return Type Bool (1 = ON, 0 = OFF)

Overlapping? No

Default Off

Sense:Bandwidth Commands

SENSe<cnum>:BANDwidth | BWIDth[:RESolution] <num>

(Read-Write) Set the bandwidth of the IF filter during the measurement. Keywords BAND and BWID are interchangeable.

Parameter

<cnm> Any existing channel number; if unspecified, set to 1.

IFBW, in the unit of Hz. Options:

<num> 1 | 2 | 3 | 5 | 7 | 10 | 15 | 20 | 30 | 50 | 70 | 100 | 150 | 200 | 300 | 500 | 700 | 1k | 1.5k | 2k | 3k | 5k | 7k | 10k | 15k | 20k | 30k | 35k | 40k |

If the inputted value is excluded, then the analyzer will select the nearest value (if the inputted value is larger than the max in the list, then it selects the max).

Example

```
SENS:BWID 1KHZ
sense2:bandwidth:resolution 1000
```

Query Syntax SENSE<cnm>:BANDwidth | BWIDth[:RESolution]?

Return Type Char

Overlapping? No

Default 35k

Sense:Correction Commands

Perform and apply the measurement calibration and other error correction characteristics.

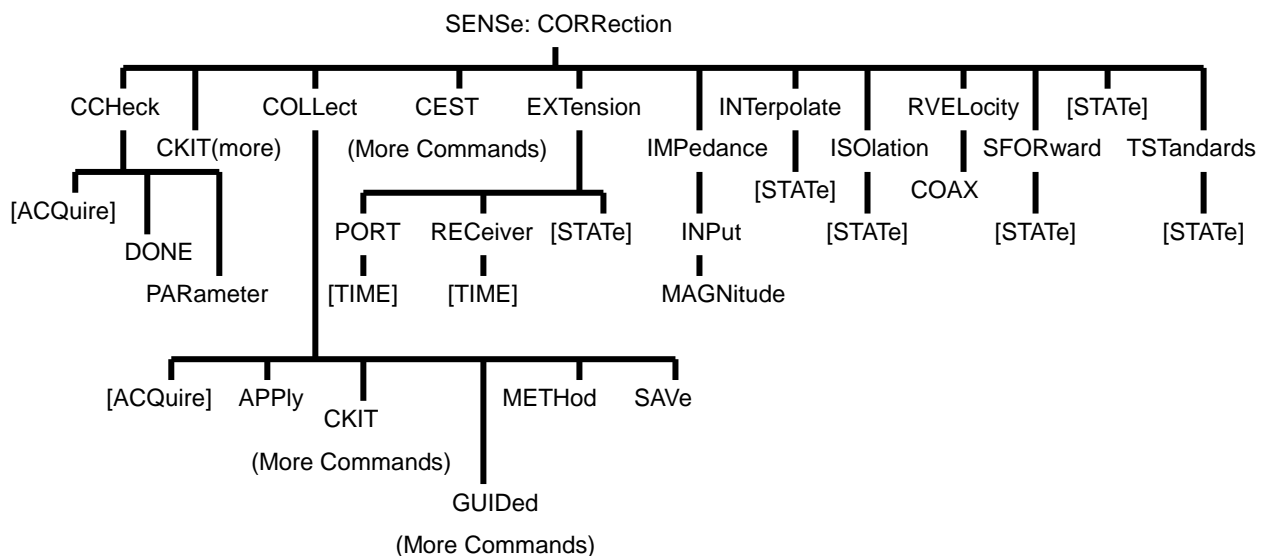

(Note: The electric calibration-related commands are determined by the instrument configuration).

SENSE<cnm>:CORRection:CCHeck[:ACQUIRE] <char>[,char]

(Write only) Read the "Confirmation Message" associated with the specified module, and write it to the memory. Use SENSE:CORR:CCH:PAR command to select measurement. This command is compatible with *OPC commands.

Parameter

<num>	Any existing channel number; if unspecified, set to 1.
<char>	Electric calibration module including "Confirmation Message". Options: ECALA ECALB
[char]	Optional parameters. Specify the characteristic character in electric calibration module for reading "Confirmation Message". If unspecified, default to CHAR0. <char> CHAR0 factory setting (data is stored in the electric calibration module) CHAR1 user self-defining description (write into the module as per the descriptive data self-defined by user on analyzer).

Example

```
SENS:CORR:CCHeck ECALA
sense2:correction:ccheck:acquire ecalb,char1
```

Query Syntax NONE

Overlapping? No

Default NONE

SENSe<num>:CORRection:CCHeck:DONE

(Read only) End the confirmation check and set the electric calibration module to idle mode.

Parameter

<num> Any existing channel number; if unspecified, set to 1.

Example

```
SENS:CORR:CCH:DONE sense2:correction:ccheck:done
```

Query Syntax NONE

Overlapping? No

Default NONE

SENSe<num>:CORRection:CCHeck:PARAmeter <Mname>

(Read-Write) Specify a measurement for confirmation check.

Parameter

<num> Any existing channel number; if unspecified, set to 1.

<Mname> Measurement name selected for confirmation check. This measurement must already exist.

Example

```
SENS:CORR:CCH:PAR 'TEST'
```

'For confirmation check, select the measurement "test" on Channel 1.

```
sense2:correction:ccheck:parameter 'test'
```

'For confirmation check, select the measurement "test" on Channel 2.

Query Syntax SENSE<cnum>:CORRection:CCHeck:PARAmeter?
Return the measurement name selected from the channel <cnum>.

Overlapping? No

Default "CH1_WIN1_LINE1_PARAM1"

SENSe<cnum>:CORRection:COLLect[:ACQuire] <class>[,subclass]

(Write only) Specify the standard for the selected calibration kit for measurement. Use Sense:Correction:Collect:CKIT command to select the calibration kit.

Note: Before using this command, it must set the following two items:

>Use SENS:CORR:COLL:METH command to set the calibration type.

>Use CALC:PAR:SEL command to select the measurement. Each channel can select a measurement.

Parameter

<cnum> Any existing channel number; if unspecified, set to 1.

Options:

<class> Standard for measuring the corresponding classes:

STAN1 S11A and S22A

STAN2 S11B and S 2B

STAN3 S11C and S22C

STAN4 S21T and S12T - Usually HRU standard

STAN5 isolation generally; not associated with calibration kit definition

<class> ECALA ECAL Module A

ECALB ECAL Module B

SLSET Set "Slide load type", and add "slide times" counting. Slide times are vitally important to the correct operation of slide load. See Slide Lode Example.

SLDONE Calculate slide load by using "Simulation to calculate the center of circle" algorithm to calculate the slide load

TRLT TRL through standard

TRLR1 TRL reflection standard (Port 1)

TRLR2 TRL reflection standard (Port 2)

TRLL TRL transmission line/matching standard

TRLI TRL isolation standard

Optional parameters.

For mechanical calibration kit, this parameter is used to select the standard in the below table, use SENS:CORR:COLL:CKIT:ORDer command to get the standard list. If unspecified, default to SST1.

<sub lass> Standard for measuring the corresponding classes:

SST1 1st standard in the list

SST2 2nd standard in the list

SST3 3rd standard in the list

SST4 4th standard in the list

[subclass]

SST5 5th standard in the list

SST6 6th standard in the list

SST7 7th standard in the list

For electric calibration, this parameter is used to specify the electric calibration module characteristic during this data collection. If unspecified, default to CHAR0.

<char> Standard for measuring the corresponding classes:

CHAR0 Default characteristic (data in electric calibration module is stored by the manufacturer)

CHAR1 User characteristic (data in electric calibration module is written by user via network analyzer)

Example

```
SENS:CORR:COLL STAN1
'If specify SENS:CORR:COLL:CKIT:ORDer2 5,3,7, then the following command
measures Standard 3(2nd item in the list)
sense1:correction:collect:acquire stan3,sst2
SENS:CORR:COLL ECALA
sense2:correction:collect:acquire ecalb,char1
```

Query
Syntax

NONE

Overlapping? No

Default NONE

SENSe<num>:CORRection:COLLect:APPLy

(Write only) Apply the error item to the measurement, which can be selected via Calc:Par:Select.

Note: When it needs to correct the error item, it is the only necessary command. If not needing to correct the error item, use SENS:CORR:COLL:ACQuire command to measure the calibration standard first, then use SENSe<num>:CORRection:COLLect:SAVE command to calculate before automatically

applying the error item.

Parameter

<num> Any existing channel number; if unspecified, set to 1.

Example

```

CALCulate:PARAmeter:SElect 'CH1_WIN0_LINE0_PARAM0' 'Select the measurement
to be applied with error item.
SENSe:CORRection:COLLect:METHod SPARSOLT 'Set the calibration type.
3. Perform calibration
4. CALCulate:DATA? SCORR1 ' Download error item.
5. Correct the error item here.
6. CALCulate:DATA SCORR1 'Upload error item (attention: SCORR1 should be followed
by error data, otherwise wrong command).
7. SENSe:CORRection:COLLect:APPLy 'Apply error item to the measurement.

```

Query Syntax NONE

Overlapping? No

Default NONE

SENSe<num>:CORRection:COLLect:METHod <char>

(Read-Write) Set the calibration type.

Parameters

<num>

Any existing channel number; if unspecified, set to 1.

<char>

Choose from:

Method	Description
NONE	No Cal method
GUIDED	Guided calibration
REFL1OPEN	Open circuit frequency
REFL1SHORT or REFL1	Short circuit frequency response
REFL3	Single port
TRAN1	Through frequency response
TRAN2	Through frequency response and isolation
ENHANCED	Enhanced frequency response
SPARSOLT	Full dull-port SOLT
SPARTRL	Full dull-port TRL
QSOLT	Quick SOLT

Example `SENS:CORR:COLL:METH REFL1 sense2:correction:collect:method sparsolt`

Query Syntax `SENSe<cnum>:CORRection:COLLEct:MEtHod?`

Return Type Char

Overlapping? No

Default NONE

SENSe<cnum>:CORRection:COLLEct:SAVE

(Write only) Use the selected :MEtHod to calculate error item and apply it to the selected measurement (turn on the error correction function).

Parameter

<cnum> Any existing channel number; if unspecified, set to 1.

Example `SENS:CORR:COLL:SAVE sense2:correction:collect:save`

Query Syntax NONE

Overlapping? No

Default NONE

SENSe<cnum>:CORRection:EXTension:PORT<pnum>[:TIME] <num>

(Read-Write) Set the extension value of the specified port. It must use SENS:CORR:EXT ON command to turn on port extension function simultaneously.

Parameter

<cnum> Any existing channel number; if unspecified, set to 1.

Port number to be extended. If unspecified, set to 1. Options:

<pnum> 1 Port 1

2 Port 2

<num> Port extension. In the unit of second, can include a suffix. Value range: -10 ~ 10.

Example `SENS:CORR:EXT:PORT 2MS sense2:correction:extension:port2 .00025`

Query Syntax `SENSe<cnum>:CORRection:EXTension:PORT<pnum> [:TIME]?`

Return Type Char

Overlapping? No

Default 0

SENSe<cnum>:CORRection:EXTension:RECeiver<Rnum>[:TIME] <num>

(Read-Write) Set the extension value of the specified receiver. It must use SENS:CORR:EXT ON command to turn on port extension function simultaneously.

Parameter

<cnum> Any existing channel number; if unspecified, set to 1.

Receiver number to receive the extension value. If unspecified, set to 1. Options:

<Rnum> 1 Receiver A
2 Receiver B

<num> Electricity length, in the unit of second, can include a suffix. Value range: -10 ~ 10.

Example `SENS:CORR:EXT:REC 2MS sense2:correction:extension:receiver2:time .00025`

Query Syntax `SENSe<cnum>:CORRection:EXTension:RECeiver<Rnum> [:TIME]?`

Return Type Char

Overlapping? No

Default 0

SENSe<cnum>:CORRection:EXTension[:STATe] <ON | OFF>

(Read-Write) Turn on or off port extension.

Parameter

<cnum> Any existing channel number; if unspecified, set to 1.

<ON | OFF> ON (or 1) - Turn on port extension.
OFF (or 0) - Turn off port extension.

Example `SENS:CORR:EXT ON
sense2:correction:extension:state off`

Query Syntax `SENSe<cnum>:CORRection:EXTension[:STATe]?`

Return Type Bool (1 = ON, 0 = OFF)

Overlapping? No

Default OFF

SENSe:CORRection:IMPedance:INPut:MAGNitude <num>

(Read-Write) Set system impedance value for analyzer.

Parameter

<num> System Impedance value, in the unit of ph, Optional range: 0 to 1000 Ohm.

Example

```
SENS:CORR:IMP:INP:MAGN 75
sense:correction:impedance:input:magnitude 50.5
```

Query
Syntax

SENSe:CORRection:IMPedance: INPut:MAGNitude?

Return Type Char

Overlapping? No

Default 50

SENSe<cnum>:CORRection:INTerpolation[:STATe] <ON | OFF>

(Read-Write) Turn on or off the interpolation function of calibration.

Parameter

<cnum> Any existing channel number; if unspecified, set to 1.

<ON | OFF> ON (or 1) - Turn on interpolation.
OFF (or 0) - Turn off interpolation.

Example

```
SENS:CORR:INT ON
sense2:correction:interpolation:state off
```

Query
Syntax

SENSe<cnum>:CORRection:INTerpolation[:STATe]?

Return Type Bool (1 = ON, 0 = OFF)

Overlapping? No

Default ON

SENSe<cnm>:CORRection:ISOLation[:STATe] <ON | OFF>

(Read-Write) Turn on or off the isolation calibration function during full 2-port calibration. If not sending this command, the default status is turning on isolation calibration.

Parameter

<cnm> Any existing channel number; if unspecified, set to 1.

<ON | OFF> ON (or 1) - Turn on isolation calibration.
 OFF (or 0) - Turn off isolation calibration.

Example

```
SENS:CORR:ISOL ON
sense2:correction:isolation:state off
```

Query
Syntax

```
SENSe<cnm>:CORRection:ISOLation[:STATe]?
```

Return Type BOOL (1 = ON, 0 = OFF)

Overlapping? No

Default ON

SENSe<cnm>:CORRection:RVELocity:COAX <num>

(Read-Write) Set the factor coefficient for electric delay and port extension.

Parameter

<cnm> Any existing channel number; if unspecified, set to 1.

<num> Velocity factor. Value range:
 0-10 (0.66 PE dielectric; 0.7 PTFE dielectric)
 Note: When calculating the electric delay of reflectance measurement (on two directions), multiply velocity factor by 2.

Example

```
SENS:CORR:RVEL:COAX .66
sense2:correction:rvelocity:coax .70
```

Query
Syntax

```
SENSe<cnm>:CORRection:RVELocity:COAX?
```

Return Type Char

Overlapping? No

Default 1

SENSe:CORRection:SFORward[:STATe] <boolean>

(Read-Write) When the calibration uses only a standard, set the direction of calibration. Use `SENSe:CORRection:TStandards[:STATe] OFF` command to specify using only a standard for calibration.

Parameter

<boolean> ON (1) - Perform forward 2-port calibration.
OFF (0) - Perform backward 2-port calibration.

Example

```
SENS:CORR:SFOR 1
sense:correction:sforward:state 0
See this command Example
```

Query
Syntax

`SENSe:CORRection:SFORward[:STATe]?`

Return Type `BOOL (1 = ON, 0 = OFF)`

Overlapping? No

Default ON

SENSe<cnum>:CORRection[:STATe] <ON | OFF>

(Read-Write) Set whether to correct the measurement data.

Parameter

<cnum> Any existing channel number; if unspecified, set to 1.

<ON | OFF> ON (or 1) - Correct.
OFF (or 0) - Not correct.

Example

```
SENS:CORR ON
sense2:correction:state off
```

Query
Syntax

`SENSe<cnum>:CORRection[:STATe]?`

Return Type `Bool (1 = ON, 0 = OFF)`

Overlapping? No

Default OFF

SENSe:CORRection:TSTandards[:STATe] <boolean>

(Read-Write) Specify whether to use one or two standards to get the calibration data.

Parameter

ON (1) - For full 2-port calibration (forward and backward parameters), use two standards.

<boolean> OFF (0) - For full 2-port calibration , use a standard.

For forward calibration, set SENSE:CORRection:COLLect:SFORward[:STATe] to ON, backward calibration is set to OFF.

Example

```
SENS:CORR:TST 1 sense:correction:tstandard:state 0
See this commandExample
```

Query Syntax

SENSe:CORRection:TSTandards[:STATe]?

Overlapping? No

Default ON

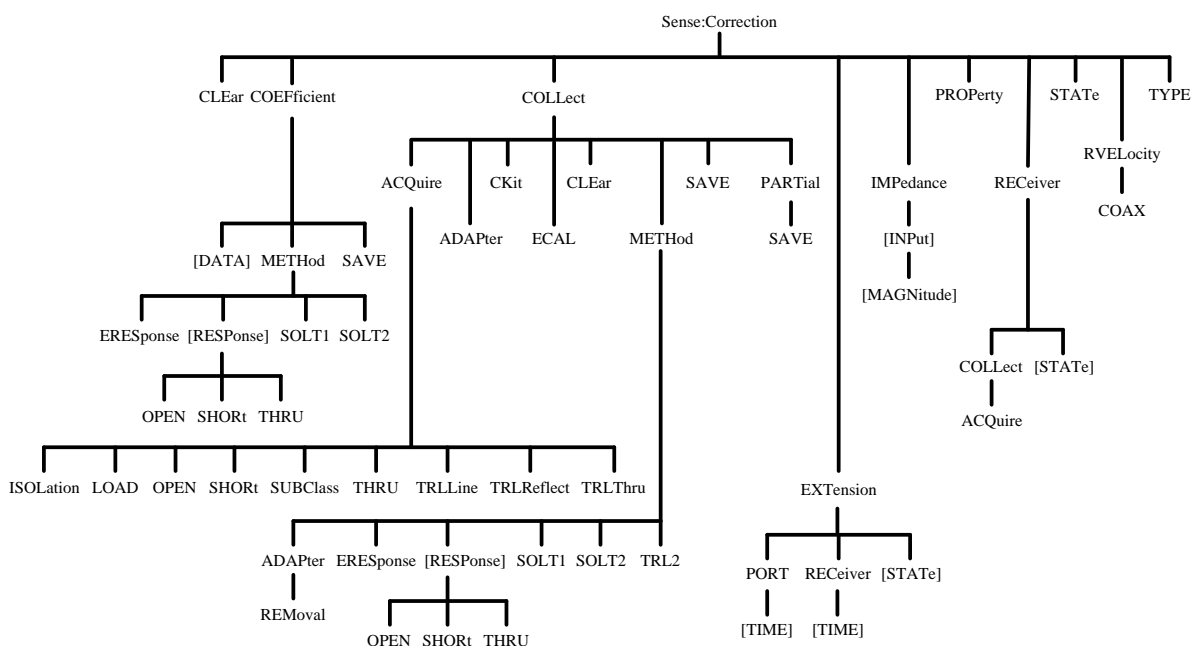

This part is compatible with program commands of Agilent ENA series vector network analyzers.
 (Note: The electric calibration-related commands are determined by the instrument configuration)

SENSe<num>:CORRection:CLEar

(Write only) Clear the error factor of calibration.

Parameter

<cnum> Any existing channel number, If unspecified, default to 1.

Example

```
SENS:CORR:CLE
sense2:correction:clear
```

Query Syntax NONE

Overlapping? No

Default NONE

SENSe<cnum>:CORRection:COEFFicient[:DATA]

<char>,<Cpt_A>,<Cpt_B>,<block>

(Read-Write) Set or get the calibration factor data of the specified channel.

Note: If the calibration coefficient has performed interpolation calculation, it will read the calibration coefficient data after such calculation.

Parameter

<cnum> Any existing channel number, If unspecified, default to 1.

Calibration type

ES - Source matching

ER - Reflection tracking

<char> ED - Directivity

EL - Load matching

ET - Transmission tracking

EX - Isolation

Response port and stimulus port.

<Cpt_A>,
<Cpt_B>

If using ES, ER or ED, response port must be same with stimulus port; while using EL, ET or EX, response port must be different with stimulus port.

Calibration coefficient data array.

<block>

There are measurement point (N) groups of data, which the nth point of coefficient data is:

Data(nx2-2) - The real part of the nth measurement point data.

Data(nx2-1) - The imaginary part of the nth measurement point data.

Example

```
SENS:CORR:COEF ES,1,1, Data 1 real part, Data 1 imaginary part,...Data N real part,
Data n imaginary part
sense2:correction:coefficient:data EL,1,2, Data 1 real part, Data 1 imaginary part,...Data
N real part, Data n imaginary part
```

Query Syntax SENS1:CORR:COEF? EL,1,2

Return Type block

Overlapping? No

Default NONE

SENSe<cnum>:CORRection:COEFFicient:METHod:ERESponse <num1>,<num2>

(Write only) When using command SENSE:CORRection:COEFFicient:DATA to write the calibration coefficient array, this command sets the calibration type of channel <cnum> to enhanced response calibration.

Parameter

<cnum> Any existing channel number, If unspecified, default to 1.

<num1>,
<num2> Response port number and stimulus port number.

Example

```
SENS:CORR:COEF:METH:ERES 1,2
sense2:correction:coefficient:method:eresponse 1,2
```

Query
Syntax NONE

Overlapping? No

Default NONE

SENSe<cnum>:CORRection:COEFFicient:METHod[:RESPonse]:OPEN <num>

(Write only) When using command SENSE:CORRection:COEFFicient:DATA to write the calibration coefficient array, this command sets the calibration type of channel <cnum> to open circuit response calibration of the specified port.

Parameter

<cnum> Any existing channel number, If unspecified, default to 1.

<num> Port number.

Example

```
SENS:CORR:COEF:METH:OPEN
sense2:correction:coefficient:method:response:open 2
```

Query
Syntax NONE

Overlapping? No

Default NONE

SENSe<cnm>:CORRection:COEFficient:MEtHod[:RESPonse]:SHORt <num>

(Write only) When using command `SENSe:CORRection:COEFficient:DATA` to write the calibration coefficient array, this command sets the calibration type of channel <cnm> to the short circuit response calibration of the specified port.

Parameter

<cnm> Any existing channel number, If unspecified, default to 1.

<num> Port number.

Example

```
SENS:CORR:COEF:METH:SHOR
sense2:correction:coefficient:method:response:short 2
```

1

Query
Syntax

NONE

Overlapping? No

Default NONE

SENSe<cnm>:CORRection:COEFficient:MEtHod[:RESPonse]:THRU <num1>,<num2>

(Write only) When using command `SENSe:CORRection:COEFficient:DATA` to write the calibration coefficient array, this command sets the calibration type of channel <cnm> to through response calibration.

Parameter

<cnm> Any existing channel number, If unspecified, default to 1.

<num1>,
<num2> Response port number and stimulus port number.

Example

```
SENS:CORR:COEF:METH:THRU 1,2
sense2:correction:coefficient:method:response:thru 1,2
```

Query
Syntax

NONE

Overlapping? No

Default NONE

SENSe<cnm>:CORRection:COEFficient:MEtHod:SOLT1 <num>

(Write only) When using command `SENSe:CORRection:COEFFicient:DATA` to write the calibration coefficient array, this command sets the calibration type of channel `<num>` to port 1 calibration.

Parameter

`<num>` Any existing channel number, If unspecified, default to 1.

`<num>` Port number.

Example

```
SENS:CORR:COEF:METH:SOLT1 1
sense2:correction:coefficient:method:solt1 2
```

Query Syntax

NONE

Overlapping? No

Default NONE

SENSe<num>:CORRection:COEFFicient:METHod:SOLT2 <num1>,<num2>

(Write only) When using command `SENSe:CORRection:COEFFicient:DATA` to write the calibration coefficient array, this command sets the calibration type of channel `<num>` to port 2 calibration.

Parameter

`<num>` Any existing channel number, If unspecified, default to 1.

`<num1>`,
`<num2>` 2 ports number of full 2-port calibration. (this setting is only valid for multi-port vector network)

Example

```
SENS:CORR:COEF:METH:SOLT2 1,2
sense2:correction:coefficient:method:solt2 1,2
```

Query Syntax

NONE

Overlapping? No

Default NONE

SENSe<num>:CORRection:COEFFicient:SAVE

(Write only) Apply the calibration array data written by command `SENSe:CORRection:COEFFicient:DATA` to the specified channel measurement.

Parameter

`<num>` Any existing channel number, If unspecified, default to 1.

Example	<code>SENS:CORR:COEF:SAVE</code> <code>sense2:correction:coefficient:save</code>
Query Syntax	NONE
Overlapping?	No
Default	NONE

SENSe<cnum>:CORRection:COLLect[:ACQuire]:ISOLation <num1>,<num2>

(Write only) Measure the isolation calibration data from the specified stimulus port to the specified response port.

Parameter

<cnum>	Any existing channel number, If unspecified, default to 1.
<num1>	Specified response port number.
<num2>	Specified stimulus port number.

Example	<code>SENS:CORR:COLL:ISOL 1,2</code> <code>sense2:correction:collect:acquire:isolation 2,1</code>
Query Syntax	NONE
Overlapping?	Yes
Default	NONE

SENSe<cnum>:CORRection:COLLect[:ACQuire]:LOAD <num>

(Write only) Measure the calibration data for load standard of the specified port.

Parameter

<cnum>	Any existing channel number, If unspecified, default to 1.
<num>	Port number.

Example	<code>SENS:CORR:COLL:LOAD 1</code> <code>sense2:correction:collect:acquire:load 2</code>
---------	---

Query Syntax NONE

Overlapping? Yes

Default NONE

SENSe<cnum>:CORRection:COLLect[:ACQuire]:OPEN <num>

(Write only) Measure the calibration data for open circuit standard of the specified port.

Parameter

<cnum> Any existing channel number, If unspecified, default to 1.

<num> Port number.

Example

```
SENS:CORR:COLL:OPEN 1
sense2:correction:collect:acquire:open 2
```

Query Syntax NONE

Overlapping? Yes

Default NONE

SENSe<cnum>:CORRection:COLLect[:ACQuire]:SHORt <num>

(Write only) Measure the calibration data for short circuit standard of the specified port.

Parameter

<cnum> Any existing channel number, If unspecified, default to 1.

<num> Port number.

Example

```
SENS:CORR:COLL:SHOR 1
sense2:correction:collect:acquire:short 2
```

Query Syntax NONE

Overlapping? Yes

Default NONE

SENSe<cnum>:CORRection:COLLect[:ACQuire]:SUBClass <num>

(Read-Write) Set/get the standard subclass of calibration.

Parameter

<cnum>	Any existing channel number, If unspecified, default to 1.
<num>	Setting number of calibration standard subclass.

Example

```
SENS:CORR:COLL:ACQ:SUBC 3
sense2:correction:collect:acquire:subclass 1
```

Query Syntax SENSE:CORRection:COLLect:ACQuire:SUBClass?

Return Type Char

Overlapping? No

Default NONE

SENSe<cnum>:CORRection:COLLect[:ACQuire]:THRU <num1>,<num2>

(Write only) Measure the calibration data for through standard of two ports.

Note: This command performs simultaneously the through standard measurement for stimulus port <num1> to response port <num2>, and through standard measurement of stimulus port <num2> to response port <num1>.

Parameter

<cnum>	Any existing channel number, If unspecified, default to 1.
<num1>, <num2>	Two port numbers are in arbitrary sequence.

Example

```
SENS:CORR:COLL:THRU 1,2
sense2:correction:collect:acquire:thru 2,1
```

Query Syntax NONE

Overlapping? Yes

Default NONE

SENSe<cnum>:CORRection:COLLect[:ACQuire]:TRLLine <num1>,<num2>

(Write only) Perform the Line or Match measurement of TRL calibration of the selected calibration kit.

Parameter

<num> Any existing channel number, If unspecified, default to 1.

<num1>, <num2> Two port numbers are in arbitrary sequence.

Example `SENS:CORR:COLL:TRLL 1,2`
`sense2:correction:collect:acquire:trlline 2,1`

Query Syntax NONE

Overlapping? Yes

Default NONE

SENSe<num>:CORRection:COLLect[:ACQuire]:TRLReflect <num>

(Write only) Perform the reflection measurement of TRL calibration of the selected calibration kit.

Parameter

<num> Any existing channel number, If unspecified, default to 1.

<num> Port number.

Example `SENS:CORR:COLL:TRLR 1 sense2:correction:collect:acquire:trlreflect 2`

Query Syntax NONE

Overlapping? Yes

Default NONE

SENSe<num>:CORRection:COLLect[:ACQuire]:TRLThru <num1>,<num2>

(Write only) Perform the through measurement of TRL calibration of the selected calibration kit.

Parameter

<num> Any existing channel number, If unspecified, default to 1.

<num1>, <num2> Two port numbers are in arbitrary sequence.

Example `SENS:CORR:COLL:TRLT 1,2`
`sense2:correction:collect:acquire:trlthru 2,1`

Query Syntax NONE

Overlapping? Yes

Default NONE

SENSe<cnm>:CORRection:COLLEct:CLEar

(Write only) Clear the calibration measurement data.

Parameter

<cnm> Any existing channel number, If unspecified, default to 1.

Example `SENS:CORR:COLL:CLE sense2:correction:collect:clear`

Query Syntax NONE

Overlapping? No

Default NONE

SENSe<cnm>:CORRection:COLLEct:METHod:ADAPter:REMOval <num>

(Write only) Set the calibration type for the adaptor removal calibration of the specified port.

Parameter

<cnm> Any existing channel number, If unspecified, default to 1.

<num> Port number.

Example `SENS:CORR:COLL:METH:ADAP:REM
sense2:correction:collect:method:adapter:removal 2`

Query Syntax NONE

Overlapping? No

Default NONE

SENSe<cnm>:CORRection:COLLEct:METHod:ERESponse <num1>,<num2>

(Write only) Set the calibration type for the enhanced response calibration between the 2 specified ports.

Parameter

<cnm> Any existing channel number, If unspecified, default to 1.

<num1>,<num2> Stimulus port number and response port number.

Example

```
SENS:CORR:COLL:METH:ERES 1,2
sense2:correction:collect:method:eresponse 1,2
```

Query Syntax NONE

Overlapping? No

Default NONE

SENSe<cnm>:CORRection:COLLect:METHod[:RESPonse]:OPEN <num>

(Write only) Set the calibration type for the open circuit response calibration of the specified port.

Parameter

<cnm> Any existing channel number, If unspecified, default to 1.

<num> Port number.

Example

```
SENS:CORR:COLL:METH:OPEN 1 sense2:correction:collect:method:response:open 2
```

Query Syntax NONE

Overlapping? No

Default NONE

SENSe<cnm>:CORRection:COLLect:METHod[:RESPonse]:SHORT <num>

(Write only) Set the calibration type for short circuit response calibration of the specified port.

Parameter

<cnm> Any existing channel number, If unspecified, default to 1.

<num> Port number.

Example

```
SENS:CORR:COLL:METH:SHOR 1
sense2:correction:collect:method:response:short 2
```

Query Syntax NONE

Overlapping? No

Default NONE

SENSe<cnum>:CORRection:COLLect:METhod[:RESPOse]:THRU <num1>,<num2>

(Write only) Set the calibration type for the through response calibration of the specified port.

Parameter

<cnum> Any existing channel number, If unspecified, default to 1.

<num1>,<num2> Stimulus port number and response port number.

Example

```
SENS:CORR:COLL:METH:THRU 1,2
sense2:correction:collect:method:response:thru 2,1
```

Query Syntax NONE

Overlapping? No

Default NONE

SENSe<cnum>:CORRection:COLLect:METhod:SOLT1 <num>

(Write only) Set the calibration type for 1-port calibration of the specified port.

Parameter

<cnum> Any existing channel number, If unspecified, default to 1.

<num> Port number.

Example

```
SENS:CORR:COLL:METH:SOLT1 1
sense2:correction:collect:method:solt1 2
```

Query Syntax NONE

Overlapping? No

Default NONE

SENSe<cnum>:CORRection:COLLect:METhod:SOLT2 <num1>,<num2>

(Write only) Set the calibration type for full 2-port calibration between 2 specified ports.

Parameter

<cnum> Any existing channel number, If unspecified, default to 1.

<num1>,<num2> Stimulus port number and response port number.

Example

```
SENS:CORR:COLL:METH:SOLT2 1,2
sense2:correction:collect:method:solt2 2,1
```

Query Syntax NONE

Overlapping? No

Default NONE

SENSe<cnum>:CORRection:COLLect:METhod:TRL2 <num1>,<num2>

(Write only) Set the calibration type for the TRIL calibration of 2 specified ports.

Parameter

<cnum> Any existing channel number, If unspecified, default to 1.

<num1>,<num2> Stimulus port number and response port number.

Example

```
SENS:CORR:COLL:METH:TRL2 1,2
sense2:correction:collect:method:trl2 2,1
```

Query Syntax NONE

Overlapping? No

Default NONE

SENSe<cnum>:CORRection:COLLect:METhod:TYPE?

(Read only) Read the selected calibration type for the selected channel <cnum>.

Parameter

<cnum> Any existing channel number, If unspecified, default to 1.

Example **SENS:CORR:COLL:METH:TYPE?**

Query Syntax **SENSe<cnum>:CORRection:COLLect:METHod:TYPE?**

Char type

AREM - Adaptor removal

ERES - Enhanced response calibration

NONE - NONE

Return Type

RESPO - Open circuit response calibration

RESPS - Short circuit response calibration

RESPT - Through response calibration

SOLT1 - 1-port calibration

SOLT2 - 2-port calibration

TRL2 - TRL 2-port calibration

Overlapping? No

Default NONE

SENSe<cnum>:CORRection:COLLect:PARTial:SAVE

(Write only). (Write only) This command (used for partial rewrite) can calculate calibration coefficient based on the calibration type selected by measured calibration data.

Parameter

<cnum> Any existing channel number, If unspecified, default to 1.

Example

SENS:CORR:COLL:PART:SAVE
sense2:correction:partial:save

Query Syntax NONE

Overlapping? No

Default NONE

SENSe<cnum>:CORRection:COLLect:SAVE

(Write only) Use the selected :METHod to calculate error item and apply it to the selected measurement (turn on the error correction function).

Parameter

<cnum> Any existing channel number, If unspecified, default to 1.

Example

SENS:CORR:COLL:SAVE

```
sense2:correction:collect:save
```

Query Syntax NONE

Overlapping? No

Default NONE

SENSE<cnm>:CORREction:IMPedance[:INPut][:MAGNitude] <num>

(Read-Write) Set/get the system characteristics impedance (Z0) value.

Parameter

<cnm> Any existing channel number, If unspecified, default to 1.

<num> System Z0 value. Double-precision floating-point, in the unit of Ohm.

Example

```
SENS:CORR:IMP 50.2
sense2:correction:impedance:input:magnitude 200
```

Query Syntax SENSE<cnm>:CORREction:IMPedance:INPut:MAGNitude?

Return Type Char

Overlapping? No

Default 50 (Ohm)

SENSE<cnm>:CORREction:PROPerty <ON|OFF>

(Read-Write) Turn on/off calibration property display.

Parameter

<cnm> Any existing channel number, If unspecified, default to 1.

<ON|OFF> ON - Turn on calibration property display.
OFF - Turn off calibration property display.

Example

```
SENS:CORR:PROP ON
sense2:correction:property off
```

Query Syntax NONE

Return Type Boolean (ON - On, OFF- Off)

Overlapping? No
 Default OFF

SENSe<cnUm>:CORRection:RECeiver<port>:COLLect:ACQuire <num>

(Write only) Perform receiver calibration targeted on the measurement of selected port <port> of selected channel <cnUm> .

Parameter

<cnUm> Any existing channel number, If unspecified, default to 1.
 <port> Port number; if unspecified, default to 1.
 <num> Correct the specified source port for receiver.

Example

```
1.
SENS:CORR:REC1:COLL:ACQ 2
OPC?
2.
sense2:correction:receiver:collect:acquire 2
opc?
```

Query Syntax NONE

Overlapping? Yes
 Default NONE

SENSe<cnUm>:CORRection:RECeiver<port>[:STATe] <ON|OFF>

(Read-Write) Turn on/off the error coefficient correction of receiver calibration.

Parameter

<cnUm> Any existing channel number, If unspecified, default to 1.
 <port> Port number; if unspecified, default to 1.
 <ON|OFF> ON - Turn on calibration error correction of receiver.
 OFF - Turn off calibration error correction of receiver.

Example

```
SENS:CORR:REC1 ON
sense2:correction:receiver:state off
```

Query Syntax SENSe<cnUm>:CORRection:RECeiver<port>:STATe?

Return Type Boolean (ON - On, OFF - Off)

Overlapping? No
 Default OFF

SENSe<cnum>:CORRection:RVELocity:COAX <num>

(Read-Write) Set/get the velocity factor.

Parameter

<port> Port number; if unspecified, default to 1.
 <num> Velocity factor. Double-precision floating-point, in the unit of 1.

Example

```
SENS:CORR:RVEL:COAX 0.7
sense2:correction:rvelocity:coax 0.55
```

Query Syntax SENSE<cnum>:CORRection:RVELocity:COAX?
 Return Type Char

Overlapping? No
 Default 1

SENSe<cnum>:CORRection:STATe <ON|OFF>

(Read-Write) Turn on/off error correction.

Parameter

<cnum> Any existing channel number, If unspecified, default to 1.
 <ON|OFF> ON - Turn on error correction.
 OFF - Turn off error correction.

Example

```
SENS:CORR:STAT ON
sense2:correction:state off
```

Query Syntax SENSE<cnum>:CORRection:STATe?
 Return Type Boolean (ON - On, OFF- Off)

Overlapping? No
 Default OFF

SENSe<cnum>:CORRection:TYPE<tr>? (Not supported)

(Read only) Targeted on active trace, read the error correction message currently being used.

Returned information includes: type,port_A,port_B,port_C,port_D

type - Applied calibration type

- “ERES”: apply enhanced response calibration.
- “NONE”: not applied.
- “RESPO”: apply response calibration (open circuit).
- “RESPS”: apply response calibration (short circuit).
- “RESPT”: apply response calibration (through).
- “SMIX2”: apply scalar mixer calibration.
- “SOLT1”: apply Port 1 calibration.
- “SOLT2”: apply full 2-por calibration.

port_A,port_B,port_C,port_D - port number applied in calibration (0 if not existed)

Parameter

<cnum> Any existing channel number, If unspecified, default to 1.

<tr> Trace number.

Example

```
SENS:CORR:TYPE2?
```

Query Syntax SENSE<cnum>:CORRection:TYPE<tr>?

Return Type Block

Overlapping? No

Default NONE

Sense:Correction:Collect:CKit Commands

Change the definition of standard for calibration kit.

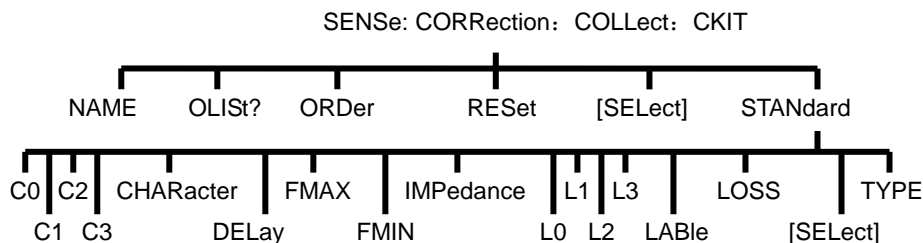

Most commands function on the currently selected standards of the currently selected calibration kits.

Use SENS:CORR:COLL:CKIT:SEL command to select calibration kit.

Use SENS:CORR:COLL:CKIT:STAN:SEL command to select calibration standard.

Note: User is required to set data for each definition field of each standard of calibration kit. For a field to be set, the default value may not the expected value.

SENSe:CORRection:COLLect:CKIT:NAME <name>

(Read-Write) Name the selected calibration kit.

Parameter

<name> Name of calibration standard. It can use any string, including number, punctuation, space and any length (although the string displayed in the dialogue box is limited in 30).

Example

```
SENS:CORR:COLL:CKIT:NAME 'MYAPC35'
sense:correction:collect:ckit:name 'mytypen'
```

Query
Syntax

SENSe:CORRection:COLLect:CKIT:NAME?

Return Type String

Overlapping? No

Default NONE

SENSe:CORRection:COLLect:CKIT:OLIST[class]?

(Read only) Return the standard value assigned to the specified class.

Parameter

Class number of calibration to be visited. The calibration classes represented by <class> number are as shown below:

<class>	Class	Description
1	S11A	Reflection Standard
2	S1 B	Reflection Standard
3	S11C	Reflection Standard
4	S21T	Through Standard
5	S22A	Reflection Standard
6	S22B	Reflection Standard
7	S22C	Reflection Standard
8	S12T	Through Standard
For 3-port Analyzer		
9	S33A	Reflection Standard
10	S33B	Reflection Standard
11	S33C	Reflection Standard
12	S32	Through Standard

13	S23T	Through Standard
14	S31T	Through Standard
15	S13T	Through Standard
TRL Calibration		
1	TRL "T"	Through Standard
17	TRL "R"	Reflection Standard
18	TRL "L"	Through Standard

Example

SENS:CORR:COLL:CKIT:OLIST8?

Return Type Char. return the <class> number of the selected standard.

Overlapping? No

Default NONE

SENSe:CORRection:COLLect:CKIT:ORDer<class> <std> [,<std>] [,<std>] [,<std>] [,<std>] [,<std>] [,<std>]

(Read-Write) Set standard number for calibration class. Not set or specify sequence for calibration standard. For more information, see: assign standard to calibration class.

Parameter

Class number of calibration assigned to <standard>. Value range: 1 to 8.
Calibration class represented by <class> number is as shown below:

<class>	Class	Description
	1 S 1A	Reflection Standard
	2 S11B	Reflection Standard
	3 S11C	Reflection Standard
	4 S21T	Through Standard
	5 S22A	Reflection Standard
<class>	6 S22B	Reflection Standard
	7 S22C	Reflection Standard
	8 S12T	Through Standard
For 3-port Analyzer		
	9 S33A	Reflection Standard
	10 S33B	Reflection Standard
	11 S33C	Reflection Standard
	1 S32T	Through Standard

13	S23T	Through Standard
14	S31T	Through Standard
15	S13T	Through Standard
TRL Calibration		
16	TRL "T"	Through Standard
17	TRL "R"	Reflection Standard
18	TRL "L"	Through Standard

<std> Standard number assigned to class; value range: 1 to 8. There is a mandatory standard; that is there are 6 optional standards.

Example

```
Assign Standard 3 to Class S11A:
SENS:CORR:COLL:CKIT:ORD1 3
Assign Standard 2 and 5 to Class S21T:
sense:correction:collect:ckit:order4 2,5
```

Query Syntax

SENSe:CORRection:COLLect:CKIT:ORDer<class>?
 'Only return the first standard assigned to the specified class. To inquire the other standards, use command SENSe:CORRection:COLLect:CKIT:OLIST[1-8]?.

Return Type Char

Overlapping? No

Default NONE

SENSe:CORRection:COLLect:CKIT:RESet <num>

(Write only) Reset the specified calibration kit to default value.

Parameter

<num> Number of calibration kit to be reset. Determined by the amount of calibration kit loaded.

Example

```
SENS:CORR:COLL:CKIT:RESet 1
sense:correction:collect:ckit:reset 4
```

Query Syntax NONE

Overlapping? No

Default NONE

SENSe:CORRection:COLLect:CKIT[:SElect] <num>

(Read-Write) Select (activate) a calibration kit, for implementing calibration or modifying standard. The

subsequent "CKIT" commands will use this calibration kit. Use SENS:CORR:COLL:CKIT:STAN <num> to select the calibration standard.

Parameter

Number of calibration kit. Options:

It can use SENSE:CORREction:COLLect:CKIT:RESet to recall the default value of calibration kit.

<num>	Name
1	User definition 1
2	User definition 2
3	User definition 3
4	User definition 4
5	User definition 5
6	User definition 6

Use SENSE:CORREction:COLLect:CKIT:RESet to restore the default value of calibration kit.

Example

```
SENS:CORR:COLL:CKIT 2
sense2:correction:collect:ckit:select 7
```

Query Syntax

SENSe:CORREction:COLLect:CKIT?

Return Type Char

Overlapping? No

Default 1

SENSe:CORREction:COLLect:CKIT:STANdard:C0 <num>

(Read-Write) Set C0 value for the selected standard (first capacitance). Pre-conditions: command SENS:CORR:COLL:CKIT:SEL is used to select calibration kit and command SENS:CORR:COLL:CKIT:STAN:SEL is used to select calibration standard.

Parameter

<num> C0 value. in the unit of PF

Example

```
The following command is used to set C0=15PF:
SENS:CORR:COLL:CKIT:STAN:C0 15
sense:correction:collect:ckit:standard:c0 15
```

Query Syntax

SENSe:CORREction:COLLect:CKIT:STANdard:C0?

Return Type Char

Overlapping? No

Default NONE

SENSe:CORRection:COLLect:CKIT:STANdard:C1 <num>

(Read-Write) Set C1 value for the selected standard (secondary capacitance). Pre-conditions: command SENS:CORR:COLL:CKIT:SEL is used to select calibration kit and command SENS:CORR:COLL:CKIT:STAN:SEL is used to select calibration standard.

Parameter

<num> C0 value. in the unit of PF

Example

The following command is used to set C1=15PF:
 SENS:CORR:COLL:CKIT:STAN:C1 15
 sense:correction:collect:ckit:standard:c1 15

Query
Syntax

SENSe:CORRection:COLLect:CKIT:STANdard:C1?

Return Type Char

Overlapping? No

Default NONE

SENSe:CORRection:COLLect:CKIT:STANdard:C2 <num>

(Read-Write) Set C2 value for the selected standard (tertiary capacitance). Pre-conditions: command SENS:CORR:COLL:CKIT:SEL is used to select calibration kit and command SENS:CORR:COLL:CKIT:STAN:SEL is used to select calibration standard.

Parameter

<num> C2 value. in the unit of PF

Example

The following command is used to set C2= -15PF:
 SENS:CORR:COLL:CKIT:STAN:C2 -15
 sense:correction:collect:ckit:standard:c2 -15

Query
Syntax

SENSe:CORRection:COLLect:CKIT:STANdard:C2?

Return Type Char

Overlapping? No

Default NONE

SENSe:CORRection:COLLect:CKIT:STANdard:C3 <num>

(Read-Write) Set C3 value for the selected standard (quartus capacitance). Pre-conditions: command SENS:CORR:COLL:CKIT:SEL is used to select calibration kit and command SENS:CORR:COLL:CKIT:STAN:SEL is used to select calibration standard.

Parameter

<num> C3 value. in the unit of PF

Example

```
The following command is used to set C3=15PF:
SENS:CORR:COLL:CKIT:STAN:C3 15
sense:correction:collect:ckit:standard:c3 15
```

Query
Syntax

SENSe:CORRection:COLLect:CKIT:STANdard:C3?

Return Type Char

Overlapping? No

Default NONE

SENSe:CORRection:COLLect:CKIT:STANdard:CHARacter <char>

(Read-Write) Set the media type of the selected calibration standard.

Parameter

<char> Media type of standard. Options:
Coax - Coaxial cable
Wave - Waveguide

Example

```
SENS:CORR:COLL:CKIT:STAN:CHAR COAX
sense:correction:collect:ckit:standard:character wave
```

Query Syntax SENS:CORRection:COLLect:CKIT:STANdard:CHARacter?

Return Type Char

Overlapping? No

Default Coax

SENSe:CORRection:COLLect:CKIT:STANdard:DELay <num>

(Read-Write) Set the electric delay value for the selected standard.

Parameter

<num> Electric delay value, in the unit of s

Example

```
SENS:CORR:COLL:CKIT:STAN:DEL 50e-12
sense2:correction:collect:ckit:standard:delay 50ps
```

Query Syntax SENSe:CORRection:COLLect:CKIT:STANdard:DELay?

Return Type Char

Overlapping? No

Default NONE

SENSe:CORRection:COLLect:CKIT:STANdard:FMAX <num>

(Read-Write) Set the max frequency value for the selected standard.

Parameter

<num> Max frequency value, in the unit of Hz.

Example

```
SENS:CORR:COLL:CKIT:STAN:FMAX 3e9
sense:correction:collect:ckit:standard:fmax 3Ghz
```

Query Syntax SENSe:CORRection:COLLect:CKIT:STANdard:FMAX?

Return Type Char

Overlapping? No

Default NONE

SENSe:CORRection:COLLect:CKIT:STANdard:FMIN <num>

(Read-Write) Set the min frequency for the selected standard.

Parameter

<num> Min frequency value, in the unit of Hz.

Example

```
SENS:CORR:COLL:CKIT:STAN:FMIN 300e3
```

```
sense:correction:collect:ckit:standard:fmin 300khz
```

Query Syntax SENSE:CORRection:COLLect:CKIT:STANdard:FMIN?

Return Type Char

Overlapping? No

Default NONE

SENSe:CORRection:COLLect:CKIT:STANdard:IMPedance <num>

(Read-Write) Set the characteristic impedance value for the selected standard.

Parameter

<num> Impedance. in the unit of ohm.

Example

```
SENS:CORR:COLL:CKIT:STAN:IMP 75
sense:correction:collect:ckit:standard:impedance 50.3
```

Query Syntax SENSE:CORRection:COLLect:CKIT:STANdard:IMPedance?

Return Type Char

Overlapping? No

Default 50

SENSe:CORRection:COLLect:CKIT:STANdard:L0 <num>

(Read-Write) Set L0 value for the selected standard (first impedance value). Pre-conditions: command SENS:CORR:COLL:CKIT:SEL is used to select calibration kit and command SENS:CORR:COLL:CKIT:STAN:SEL is used to select calibration standard.

Parameter

<num> Impedance value, in the unit of ph.

Example

```
The following command sets L0=15ph:
SENS:CORR:COLL:CKIT:STAN:L0 15
sense:correction:collect:ckit:standard:l0 15
```

Query Syntax SENSE:CORRection:COLLect:CKIT:STANdard:L0?

Return Type Char

Overlapping? No

Default NONE

SENSe:CORRection:COLLect:CKIT:STANdard:L1 <num>

(Read-Write) Set L1 value for the selected standard (secondary impedance value). Pre-conditions: command SENS:CORR:COLL:CKIT:SEL is used to select calibration kit and command SENS:CORR:COLL:CKIT:STAN:SEL is used to select calibration standard.

Parameter

<num> Impedance value, in the unit of pH.

Example

```
The following command sets L1=15ph:
SENS:CORR:COLL:CKIT:STAN:L1 15
sense:correction:collect:ckit:standard:l1 15
```

Query Syntax

SENSe:CORRection:COLLect:CKIT:STANdard:L1?

Return Type Char

Overlapping? No

Default NONE

SENSe:CORRection:COLLect:CKIT:STANdard:L2 <num>

(Read-Write) Set L2 value for the selected standard (tertiary impedance value). Pre-conditions: command SENS:CORR:COLL:CKIT:SEL is used to select calibration kit and command SENS:CORR:COLL:CKIT:STAN:SEL is used to select calibration standard.

Parameter

<num> Impedance value, in the unit of ph.

Example

```
The following command sets L2=15ph:
SENS:CORR:COLL:CKIT:STAN:L2 15
sense:correction:collect:ckit:standard:l2 15
```

Query Syntax

SENSe:CORRection:COLLect:CKIT:STANdard:L2?

Return Type Char

Overlapping? No

Default NONE

SENSe:CORRection:COLLect:CKIT:STANdard:L3 <num>

(Read-Write) Set L3 for the selected standard (quartus impedance value). Pre-conditions: command SENS:CORR:COLL:CKIT:SEL is used to select calibration kit and command SENS:CORR:COLL:CKIT:STAN:SEL is used to select calibration standard.

Parameter

<num> Impedance value, in the unit of ph.

Example

```
The following command sets L3=15ph:
SENS:CORR:COLL:CKIT:STAN:L3 15
sense:correction:collect:ckit:standard:l3 15
```

Query
Syntax

SENSe:CORRection:COLLect:CKIT:STANdard:L3?

Return Type Char

Overlapping? No

Default NONE

SENSe:CORRection:COLLect:CKIT:STANdard:LABel <name>

(Read-Write) Set label for the selected standard. Label is used to reminder the user of connecting the specified standard.

Parameter

<name> Standard level bracketed by single bracket. Any string with length of 1 to 12, not beginning with number.

Example

```
SENS:CORR:COLL:CKIT:STAN:LAB 'OPEN'
sense:correction:collect:ckit:standard:label 'Short2'
```

Query Syntax SENSe:CORRection:COLLect:CKIT:STANdard:LABel?

Return Type String

Overlapping? No

Default NONE

SENSe:CORRection:COLLect:CKIT:STANdard:LOSS <num>

(Read-Write) Set the insertion loss of the selected standard.

Parameter

<num> Insert loss value. In the unit of (Mohms / sec)

Example

```
SENS:CORR:COLL:CKIT:STAN:LOSS 3.5e9
sense:correction:collect:ckit:standard:loss 3
```

Query Syntax SENSE:CORRection:COLLect:CKIT:STANdard:LOSS?

Return Type Char

Overlapping? No

Default NONE

SENSe:CORRection:COLLect:CKIT:STANdard[:SELEct] <num>

(Read-Write) Select the calibration standard, the subsequent "CKIT" command for modifying the standard must use this standard. Use SENS:CORR:COLL:CKIT:SEL to select calibration kit.

Parameter

<num> Standard number. Value range: 1 to 8.

Example

```
SENS:CORR:COLL:CKIT:STAN 3 sense:correction:collect:ckit:standard:select 8
```

Query Syntax SENSE:CORRection:COLLect:CKIT:STANdard[:SELEct]?

Return Type Char

Overlapping? No

Default 1

SENSe:CORRection:COLLect:CKIT:STANdard:TYPE <char>

(Read-Write) Set the type of the selected standard.

Parameter

<char> Options:
Options: OPEN (open device)
SHORT (short device)
LOAD (load)
SLOAD (sliding load)

THRU (through)
ARBI (arbitrarily) (Not provided)

Example

```
SENS:CORR:COLL:CKIT:STAN:TYPE LOAD
sense:correction:collect:ckit:standard:type short
```

Query Syntax SENSE:CORREction:COLLect:CKIT:STANdard:TYPE?

Return Type Char

Overlapping? No

Default NONE

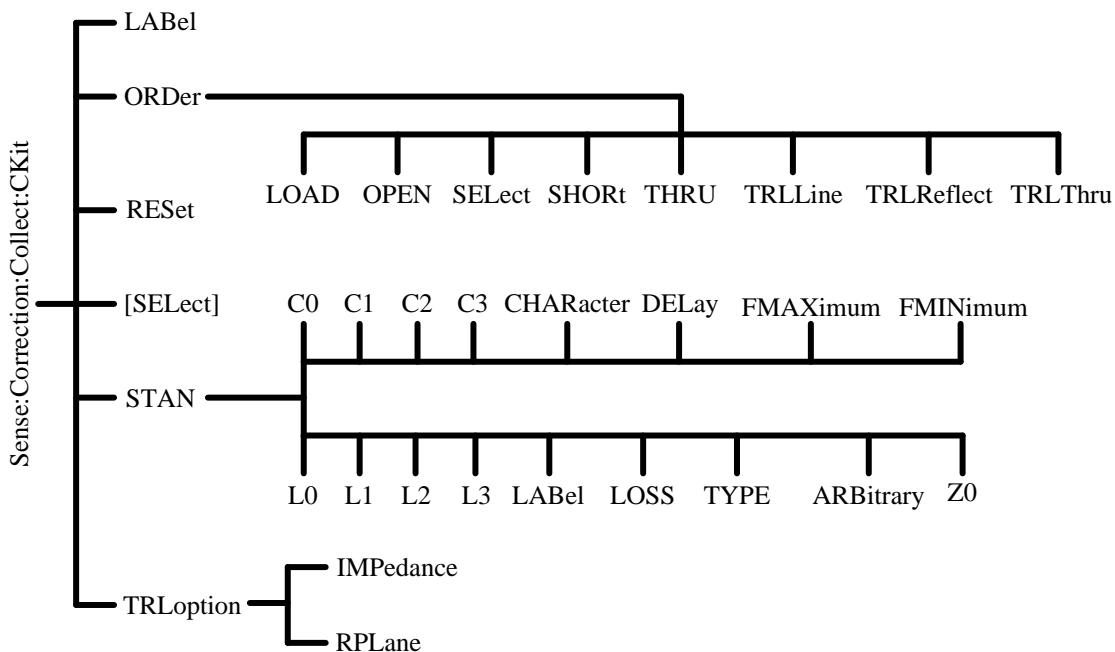

This part is compatible with program commands of Agilent ENA series vector network analyzers

SENSe<num>:CORREction:COLLect:CKIT:LABel <name>

(Read-Write) Name the selected calibration kit.

Parameter

<num> Channel number. 1~64, if unspecified, <num> is default to 1.

<name> Name of calibration standard. It can use any string, including number, punctuation, space and any length (although the string displayed in the dialogue box is limited in 30).

Example

```
SENS:CORR:COLL:CKIT:LAB 'MYAPC35'
sense:correction:collect:ckit:label 'mytypen'
```

Query Syntax SENSE:CORRection:COLLEct:CKIT:NAME?

Return Type String

Overlapping? No

Default NONE

Replaceable command SENSE:CORRection:COLLEct:CKIT:NAME

SENSe<cnum>:CORRection:COLLEct:CKIT:ORDer:LOAD <Cpt>,<num>

(Read-Write) Specify standard for load measurement.

Parameter

<cnum> Channel number. 1~64, If not specified, <cnum> is default to 1.

<Cpt> Port number.

<num> Standard number. 0~50

Example

```
SENS:CORR:COLL:CKIT:ORD:LOAD 1,3
sense:correction:collect:ckit:order:load 2,7
```

Query Syntax SENSe:CORRection:COLLEct:CKIT:ORDer:LOAD? 1

Return Type Char

Overlapping? No

Default NONE

Replaceable command SENSe:CORRection:COLLEct:CKIT:ORDer

SENSe<cnum>:CORRection:COLLEct:CKIT:ORDer:OPEN <Cpt>,<num>

(Read-Write) Specify standard for port Cpt open circuit measurement.

Parameter

<cnum> Channel number. 1~64, If not specified, <cnum> is default to 1.

<Cpt> Port number. 1~2

<num> Standard number. 0~50

Example **SENS:CORR:COLL:CKIT:ORD:OPEN 1,8**
 sense:correction:collect:ckit:order:open 2,1

Query Syntax **SENSe:CORRection:COLLect:CKIT:ORDer:OPEN? 2**

Return Type Char

Overlapping? No

Default NONE

Replaceable
command **SENSe:CORRection:COLLect:CKIT:ORDer**

SENSe<cnum>:CORRection:COLLect:CKIT:ORDer:SELEct <num>

(Read-Write) Set/Get the standard subclass of calibration.

Parameter

<cnum> Channel number. 1~64, if unspecified, <cnum> is default to 1.

<num> Number of calibration standard subclass. 1~30

Example **SENS:CORR:COLL:CKIT:ORD:SEL 2**
 sense:correction:collect:ckit:order:select 10

Query Syntax **SENSe:CORRection:COLLect:CKIT:ORDer:SELEct?**

Return Type Char

Overlapping? No

Default 1

Replaceable
command NONE

SENSe<cnum>:CORRection:COLLect:CKIT:ORDer:SHORt <Cpt>,<num>

(Read-Write) Specify standard for port Cpt short circuit measurement.

Parameter

<cnum> Channel number. 1~64, if unspecified, <cnum> is default to 1.

<Cpt> Port number. 1~2

<num> Standard number. 0~50

Example

```
SENS:CORR:COLL:CKIT:ORD:SHOR 1,3
sense:correction:collect:ckit:order:short 2,9
```

Query Syntax SENSE:CORRection:COLLect:CKIT:ORDer:SHORT? 2

Return Type Char

Overlapping? No

Default NONE

Replaceable command SENSE:CORRection:COLLect:CKIT:ORDer

SENSe<cnum>:CORRection:COLLect:CKIT:ORDer:THRU <Cpt1_A>,<Cpt_B>,<num>

(Read-Write) Specify standard for transmission measurement.

Parameter

<cnum> Channel number. 1~64, if unspecified, <cnum> is default to 1.

<Cpt_A>,
<Cpt_B> Specify two ports of Through Standard in arbitrary sequence.

<num> Standard number. 0~50

Example

```
SENS:CORR:COLL:CKIT:ORD:THRU 1,2,9
sense:correction:collect:ckit:order:thru 2,1,3
```

Query Syntax SENSE:CORRection:COLLect:CKIT:ORDer:THRU? 1,2

Return Type Char

Overlapping? No

Default NONE

Replaceable command SENSE:CORRection:COLLect:CKIT:ORDer

SENSe<cnum>:CORRection:COLLect:CKIT:ORDer:TRLLine <Cpt1_A>,<Cpt_B>,<num>

(Read-Write) Specify standard for line measurement of TRL calibration

Parameter

<num>	Channel number. 1~64, if unspecified, <num> is default to 1.
<Cpt_A>, <Cpt_B>	Specify two ports of line measurement of TRL calibration in arbitrary sequence.
<num>	Standard number. 0~50

Example

```
SENS:CORR:COLL:CKIT:ORD:TRLL 1,2,14
sense:correction:collect:ckit:order:trlline 1,2,4
```

Query Syntax SENSE:CORRection:COLLect:CKIT:ORDer:TRLLine? 2,1

Return Type Char

Overlapping? No

Default NONE

Replaceable command SENSE:CORRection:COLLect:CKIT:ORDer

SENSe<num>:CORRection:COLLect:CKIT:ORDer:TRLReflect <num>

(Read-Write) Specify standard for reflection measurement of TRL calibration.

Parameter

<num>	Channel number. 1~64, if unspecified, <num> is default to 1.
<num>	Standard number. 0~50

Example

```
SENS:CORR:COLL:CKIT:ORD:TRLR 3
sense:correction:collect:ckit:order:trlreflect 5
```

Query Syntax SENSE:CORRection:COLLect:CKIT:ORDer:TRLReflect?

Return Type Char

Overlapping? No

Default NONE

Replaceable command SENSE:CORRection:COLLect:CKIT:ORDer

SENSe<num>:CORRection:COLLect:CKIT:ORDer:TRLThru <Cpt1_A>,<Cpt_B>,<num>

(Read-Write) Specify standard for through measurement of TRL calibration.

Parameter

<num>	Channel number. 1~64, if unspecified, <num> is default to 1.
<Cpt_A>, <Cpt_B>	Specify two ports for Through Standard of TRL Calibration in arbitrary sequence.
<num>	Standard number. 0~50

Example

```
SENS:CORR:COLL:CKIT:ORD:TRLT 1,2,5
sense:correction:collect:ckit:order:trlthru 1,2,4
```

Query Syntax SENSE:CORRection:COLLect:CKIT:ORDer:TRLThru? 1,2

Return Type Char

Overlapping? No

Default NONE

Replaceable command SENSE:CORRection:COLLect:CKIT:ORDer

SENSe<num>:CORRection:COLLect:CKIT:RESet

(Write only) Reset the calibration kit to factory settings.

Parameter

<num> Channel number. 1~64, if unspecified, <num> is default to 1.

Example

```
SENS:CORR:COLL:CKIT:RES
sense:correction:collect:ckit:reset
```

Query Syntax NONE

Return Type NONE

Overlapping? No

Default NONE

Replaceable command SENSE:CORRection:COLLect:CKIT:RESet <num>

SENSe<cnum>:CORRection:COLLect:CKIT[:SELEct] <num>

(Read-Write) Select calibration kit or get the index of the calibration kit currently selected.

Parameter

<cnum> Channel number. 1~64, if unspecified, <cnum> is default to 1.

<num> Index of calibration kit.

Example

```
SENS:CORR:COLL:CKIT 2
sense:correction:collect:ckit:select 15
```

Query Syntax SENSE:CORRection:COLLect:CKIT:SELEct?

Return Type Char

Overlapping? No

Default 1

Replaceable command SENSE:CORRection:COLLect:CKIT:SELEct

SENSe<cnum>:CORRection:COLLect:CKIT:STAN<std>:ARBitrary <num>

(Read-Write) Set or get arbitrarily impedance of standard (std).

Parameter

<cnum> Channel number. 1~64, if unspecified, <cnum> is default to 1.

<std> Standard number, with range from 1 to 50.

<num> Arbitrarily impedance value, double-precision floating-point, in the unit of Ohm.

Example

```
SENS:CORR:COLL:CKIT:STAN2:ARB 62
sense:correction:collect:ckit:stan1:arbitrary 50.5
```

Query Syntax SENSE:CORRection:COLLect:CKIT:STAN4:ARB?

Return Type Char

Overlapping? No

Default NONE

Replaceable command NONE

SENSe<num>:CORRection:COLLect:CKIT:STAN<std>:C0 <num>

(Read-Write) Set or get C0 of standard (std).

Parameter

<num> Channel number. 1~64, if unspecified, <num> is default to 1.
 <std> Standard number, with range from 1 to 50.
 <num> C0 value. Double-precision floating-point, in the unit of fF(1 thousand-billionth of an F):
 1E-15 F

Example

```
SENS:CORR:COLL:CKIT:STAN3:C0 89.9
sense:correction:collect:ckit:stan2:c0 30.2
```

Query Syntax SENSE:CORRection:COLLect:CKIT:STAN3:C0?

Return Type Char

Overlapping? No

Default NONE

Replaceable command SENSE:CORRection:COLLect:CKIT:STANdard:C0

SENSe<num>:CORRection:COLLect:CKIT:STAN<std>:C1 <num>

(Read-Write) Set or get C0 of standard (std).

Parameter

<num> Channel number. 1~64, if unspecified, <num> is default to 1.
 <std> Standard number, with range from 1 to 50.
 <num> C0 value. Double-precision floating-point, 1E-27F/Hz

Example

```
SENS:CORR:COLL:CKIT:STAN:C1 2536.8
sense:correction:collect:ckit:stan:c1 1201
```

Query Syntax SENSE:CORRection:COLLect:CKIT:STAN3:C1?

Return Type Char

Overlapping? No
 Default NONE

Replaceable command SENSE:CORRection:COLLect:CKIT:STANdard:C1

SENSe<num>:CORRection:COLLect:CKIT:STAN<std>:C2 <num>

(Read-Write) Set or get C0 of standard (std).

Parameter

<num> Channel number. 1~64, if unspecified, <num> is default to 1.
 <std> Standard number, with range from 1 to 50.
 <num> C0 value. Double-precision floating-point, in the unit of 1E-36F/Hz2

Example

```
SENS:CORR:COLL:CKIT:STAN:C2 -264.98
sense:correction:collect:ckit:stan:c2 32
```

Query Syntax SENSE:CORRection:COLLect:CKIT:STAN:C2?

Return Type Char

Overlapping? No
 Default NONE

Replaceable command SENSE:CORRection:COLLect:CKIT:STANdard:C2

SENSe<num>:CORRection:COLLect:CKIT:STAN<std>:C3 <num>

(Read-Write) Set or get C0 of standard (std).

Parameter

<num> Channel number. 1~64, if unspecified, <num> is default to 1.
 <std> Standard number, with range from 1 to 50.
 <num> C0 value. Double-precision floating-point, in the unit of 1E-45F/Hz3

Example

```
SENS:CORR:COLL:CKIT:STAN:C3 13.4
sense:correction:collect:ckit:stan:c3 45.1
```

Query Syntax SENSE:CORRection:COLLEct:CKIT:STAN:C3?

Return Type Char

Overlapping? No

Default NONE

Replaceable command SENSE:CORRection:COLLEct:CKIT:STANdard:C3

SENSe<num>:CORRection:COLLEct:CKIT:STAN<std>:CHARacter <char>

(Read-Write) Set or get media type of standard (std).

Parameter

<num> Channel number. 1~64, if unspecified, <num> is default to 1.

<std> Standard number, with range from 1 to 50.

<char> COAXial - Coaxial.
WAVEguide - Waveguide.

Example

```
SENS:CORR:COLL:CKIT:STAN:CHAR COAX
sense:correction:collect:ckit:stan1:character waveguide
```

Query Syntax SENSE:CORRection:COLLEct:CKIT:STAN3:CHAR?

Return Type Char

Overlapping? No

Default COAXial (coaxial)

Replaceable command SENSE:CORRection:COLLEct:CKIT:STANdard:CHARacter <Coax/Wave>

SENSe<num>:CORRection:COLLEct:CKIT:STAN<std>:DELay <num>

(Read-Write) Set or get offset time delay of standard (std).

Parameter

<num> Channel number. 1~64, if unspecified, <num> is default to 1.

<std> Standard number, with range from 1 to 50.

<num> Time delay. Double-precision floating-point, in the unit of s (second).

Example

```
SENS:CORR:COLL:CKIT:STAN2:DEL 4.19E-11
sense:correction:collect:ckit:stan:delay 3.1e-7
```

Query Syntax SENSE:CORRection:COLLect:CKIT:STAN:DELay?

Return Type Char

Overlapping? No

Default NONE

Replaceable command SENSE:CORRection:COLLect:CKIT:STANdard:DELay

SENSe<cnum>:CORRection:COLLect:CKIT:STAN<std>:FMAXimum <num>

(Read-Write) Set or get max. frequency of standard (std).

Note: Set the max. frequency of the cut-off frequency when the media type of the standard is set to "Waveguide"

Parameter

<cnum> Channel number. 1~64, if unspecified, <cnum> is default to 1.

<std> Standard number, with range from 1 to 50.

<num> Max frequency, Range 0~999E9, unit Hz

Example

```
SENS:CORR:COLL:CKIT:STAN2:FMAX 3e9
sense:correction:collect:ckit:stan:fmaximum 1.5e9
```

Query Syntax SENSE:CORRection:COLLect:CKIT:STAN:FMAXimum?

Return Type Char

Overlapping? No

Default NONE

Replaceable command SENSE:CORRection:COLLect:CKIT:StANdard:FMAX

SENSe<cnum>:CORRection:COLLect:CKIT:STAN<std>:FMINimum <num>

(Read-Write) Set or get min. frequency of standard (std).

Note: Set the min. frequency of the cut-off frequency when the media type of the standard is set to

"Waveguide"

Parameter

<num>	Channel number. 1~64, if unspecified, <num> is default to 1.
<std>	Standard number, with range from 1 to 50.
<num>	Min. frequency, Range 0~999E9, unit Hz

Example

```
SENS:CORR:COLL:CKIT:STAN5:FMIN 2e6
sense:correction:collect:ckit:stan:fminimum 300e3
```

Query Syntax SENSE:CORRection:COLLect:CKIT:STAN:FMINimum?

Return Type Char

Overlapping? No

Default NONE

Replaceable command SENSE:CORRection:COLLect:CKIT:STANdard:FMIN

SENSe<num>:CORRection:COLLect:CKIT:STAN<std>:L0 <num>

(Read-Write) Set or get C0 of standard (std).

Parameter

<num>	Channel number. 1~64, if unspecified, <num> is default to 1.
<std>	Standard number, with range from 1 to 50.
<num>	C2 value. Double-precision floating-point, in the unit of ph (1 millionth of an H).

Example

```
SENS:CORR:COLL:CKIT:STAN:L0 3.4
sense:correction:collect:ckit:stan:l0 16
```

Query Syntax SENSE:CORRection:COLLect:CKIT:STAN:L0?

Return Type Char

Overlapping? No

Default NONE

Replaceable SENSE:CORRection:COLLect:CKIT:STANdard:L0

 command

SENSe<cnum>:CORRection:COLLect:CKIT:STAN<std>:L1 <num>

(Read-Write) Set or get C0 of standard (std).

Parameter

<cnum> Channel number. 1~64, If not specified, <cnum> is default to 1.

<std> Standard number, with range from 1 to 50.

<num> C2 value. Double-precision floating-point, in the unit of 1E-24H/Hz

Example

```
SENS:CORR:COLL:CKIT:STAN:L1 -496.2
sense:correction:collect:ckit:stan:l1 120
```

Query Syntax SENSE:CORRection:COLLect:CKIT:STAN:L1?

Return Type Char

Overlapping? No

Default NONE

Replaceable command SENSE:CORRection:COLLect:CKIT:STANdard:L1

SENSe<cnum>:CORRection:COLLect:CKIT:STAN<std>:L2 <num>

(Read-Write) Set or get C0 of standard (std).

Parameter

<cnum> Channel number. 1~64, if unspecified, <cnum> is default to 1.

<std> Standard number, with range from 1 to 50.

<num> C2 value. Double-precision floating-point, in the unit of 1E-33H/Hz²

Example

```
SENS:CORR:COLL:CKIT:STAN:L2 34.831
sense:correction:collect:ckit:stan:l2 51
```

Query Syntax SENSE:CORRection:COLLect:CKIT:STAN:L2?

Return Type Char

Overlapping? No
 Default NONE

Replaceable command SENSE:CORRection:COLLect:CKIT:STANdard:L2

SENSe<cnum>:CORRection:COLLect:CKIT:STAN<std>:L3 <num>

(Read-Write) Set or get C0 of standard (std).

Parameter

<cnum> Channel number. 1~64, if unspecified, <cnum> is default to 1.
 <std> Standard number, with range from 1 to 50.
 <num> C2 value. Double-precision floating-point, in the unit of 1E-42H/Hz3

Example

```
SENS:CORR:COLL:CKIT:STAN3:L3 -0.785
sense:correction:collect:ckit:stan:l3 3.14
```

Query Syntax SENSE:CORRection:COLLect:CKIT:STAN:L3?

Return Type Char

Overlapping? No
 Default NONE

Replaceable command SENSE:CORRection:COLLect:CKIT:STANdard:L3

SENSe<cnum>:CORRection:COLLect:CKIT:STAN<std>:LABel <name>

(Read-Write) Set or get the name of standard (std).

Parameter

<cnum> Channel number. 1~64, if unspecified, <cnum> is default to 1.
 <std> Standard number, with range from 1 to 50.
 <name> name of calibration standard. It can use any string, including number, punctuation, space and any length (although the string displayed in the dialogue box is limited in 30).

Example

```
SENS:CORR:COLL:CKIT:STAN:LAB 'MYAPC35'
sense:correction:collect:ckit:stan2:label 'mytypen'
```

Query Syntax SENSE:CORRection:COLLect:CKIT:STAN2:LABel?

Return Type String

Overlapping? No

Default NONE

Replaceable command SENSE:CORRection:COLLect:CKIT:STANdard:LABel

SENSE<num>:CORRection:COLLect:CKIT:STAN<std>:LOSS <num>

(Read-Write) Set or get offset loss value of standard (std).

Parameter

<num> Channel number. 1~64, if unspecified, <num> is default to 1.

<std> Standard number, with range from 1 to 50.

<num> Offset loss value. Double-precision floating-point, in the unit of Ohm.

Example

```
SENS:CORR:COLL:CKIT:STAN:LOSS 1.087
sense:correction:collect:ckit:stan:loss 1.2
```

Query Syntax SENSE:CORRection:COLLect:CKIT:STAN:LOSS?

Return Type Char

Overlapping? No

Default NONE

Replaceable command SENSE:CORRection:COLLect:CKIT:STANdard:LOSS

SENSE<num>:CORRection:COLLect:CKIT:STAN<std>:TYPE <char>

(Read-Write) Set or get standard type of standard (std).

Parameter

<num> Channel number. 1~64, if unspecified, <num> is default to 1.

<std> Standard number, with range from 1 to 50.

<char> Options - Open circuit
SHORT - Short circuit

LOAD - Load
 THRU - Through
 ARBItrary - Arbitrarily impedance
 UTHRu - Unknown through
 NONE - None, the theoretic value of DUT is 0.

Example

```
SENS:CORR:COLL:CKIT:STAN:TYPE OPEN
sense:correction:collect:ckit:stan:type short
```

Query Syntax SENSE:CORRection:COLLEct:CKIT:stan4:type?

Return Type Char

Overlapping? No

Default NONE

Replaceable command SENSE:CORRection:COLLEct:CKIT:STANdard:TYPE

SENSe<cnum>:CORRection:COLLEct:CKIT:STAN<std>:Z0 <num>

(Read-Write) Set or get offset Z0 value of standard (std).

Parameter

<cnum> Channel number. 1~64, if unspecified, <cnum> is default to 1.

<std> Standard number, with range from 1 to 50.

<num> Offset impedance Z0. Double-precision floating-point, in the unit of Ohm

Example

```
SENS:CORR:COLL:CKIT:STAN3:Z0 50
sense:correction:collect:ckit:stan:z0 75
```

Query Syntax SENSE:CORRection:COLLEct:CKIT:STAN:Z0?

Return Type Char

Overlapping? No

Default NONE

Replaceable command SENSE:CORRection:COLLEct:CKIT:STANdard:IMPedance

SENSe<cnum>:CORRection:COLLect:CKIT:TRLOption:IMPedance <char>

(Read-Write) Set or get reference impedance during TRL calibration.

Parameter

<cnum>	Channel number. 1~64, if unspecified, <cnum> is default to 1.
	Reference impedance during TRL calibration.
<char>	SYSTEM - Calculating the error coefficient by setting the system impedance as reference impedance LINE - Calculating the error coefficient by setting the characteristic impedance of line standard as reference impedance

Example

```
SENS:CORR:COLL:CKIT:TRL:IMP SYST
sense:correction:collect:ckit:trloption:impedance line
```

Query Syntax SENSE:CORRection:COLLect:CKIT:TRLOption:IMPedance?

Return Type Char

Overlapping? No

Default SYSTEM

Replaceable command NONE

SENSe<cnum>:CORRection:COLLect:CKIT:TRLOption:RPLane <char>

(Read-Write) Set/get the calculation method of the calibration plane.

Parameter

<cnum>	Channel number. 1~64, if unspecified, <cnum> is default to 1.
	Calculation method of calibration plane.
<name>	THRU - Calculating the calibration plane with the standard lengths of through and line REFLect - Calculating the calibration plane with the reflection coefficient of the reflection standard

Example

```
SENS:CORR:COLL:CKIT:TRL:RPLane THRU
sense:correction:collect:ckit:trloption:rplane reflect
```

Query Syntax SENSE:CORRection:COLLect:CKIT:TRLOption:RPLane?

Return Type Char

Overlapping? No

Default THRU

Replaceable
command NONE

Sense:Correction:CSET Commands

Operate on calibration set.

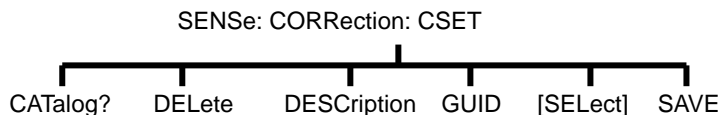

(Note: Commands of this command block are not provided temporarily)

SENSe<cnun>:CORRection:CSET:CATalog?

(Read only) Return the string of calibration set GUID list separated by comma.

Parameter

<cnun> Any existing channel number; if unspecified, set to 1.

Example `SENS:CORR:CSET:CAT? sense2:correction:cset:catalog?`

Overlapping? No

Default NONE

SENSe<cnun>:CORRection:CSET:DELEte <string>

(Write only) Delete a calibration set from calibration set. This command updates the calibration set file on hard disk immediately. Calibration set collection is a more convenient way for calibration set management. If the calibration set specified by GUID is being used, it will not delete the calibration set. To delete a calibration set in use, it can follow the below methods: Turn off the correction function of the specified measurement, turn off the specified channel, or select another calibration set for a specified channel.

Parameter

<cnun> Any existing channel number; if unspecified, set to 1.

<string> GUID of calibration set to be deleted, which must include brace and hyphens, not case sensitive.

Example `SENS:CORR:CSET:DEL '{2B893E7A-971A-11d5-8-AE96}'`
`sense2:correction:cset:delete '{2B893E7A-b-6-8b2x-AE96}'`

Query Syntax NONE

Overlapping? No

Default NONE

SENSe<num>:CORRection:CSET:DESCRiption <string>

(Read-Write) Set or return the descriptive string of the selected calibration set. User can change this string for distinguishing each calibration set. Use command SENSE:CORRection:CSET:GUID to select the calibration set.

Parameter

<num> Any existing channel number; if unspecified, set to 1.

<string> Descriptive string of the selected calibration set.

Example

```
SENS:CORR:CSET:DESC 'MyCalSet'
sense2:correction:cset:description 'thisCalSet'
```

Query Syntax SENSE<num>:CORRection:CSET:DESCRiption?

Return Type String

Overlapping? No

Default NONE

SENSe<num>:CORRection:CSET:GUID <string>

(Read-Write) Select the calibration set via GUID and apply to the specified channel.

When the channel is off, it cannot select a calibration set.

If the incentive setting of the selected calibration set is different with that of the selected channel, the vector network will automatically change the channel settings (subject to calibrate set).

Parameter

<num> Any existing channel number; if unspecified, set to 1.

<string> GUID of calibration set, which must including brace and hyphens.

Example

```
SENS:CORR:CSET:GUID '{2B893E7A-971A-11d5-8-AE96}'
sense2:correction:cset:guid '{2B893E7A-971A-11d5-8-AE96}'
```

Query Syntax SENSE<num>:CORRection:CSET:GUID?
Return the GUID of the currently selected calibration of the specified channel.

Return Type String

Overlapping? No

Default NONE

SENSe<cnUm>:CORRection:CSEt[:SElect] <char>

(Read-Write) Reload the correction data file from the memory. The file name is "CSEtx.cst", among which x represents user number assigned to <char>, .cst specifies calibration set and instrument status. It differs with the file (e.g. "at00x.cst") stored in front panel by default in file name and name syntax. For more information on the file naming syntax, see the MMEMory subsystem..

Parameter

<cnUm> Any existing channel number; if unspecified, set to 1.

Options:

DEF - Reset analyzer

<char> USER01 - Recall calibration data of User01

USER02 - Recall calibration data of User02

...

USER 10 - Recall calibration data of User10

Example

```
SENS:CORR:CSET DEF
sense2:correction:cset:select user02
```

Query Syntax SENSe<cnUm>:CORRection:CSEt[:SElect]?

Return Type Char

Overlapping? No

Default DEF

SENSe<cnUm>:CORRection:CSEt:SAVe <char>

Write the correction data file to memory or read the correction data file last stored. The file name is "CSEtx.cst", among which x represents user number assigned to <char>, .cst specifies calibration set and instrument status. It differs with the file (e.g. "at00x.cst") stored in front panel by default in file name and name syntax. For more information on the file naming syntax, see the MMEMory subsystem..

Parameter

<cnUm> Any existing channel number; if unspecified, set to 1.

Value range:

USER01

<char> USER02...

USER10

Example

```
SENS:CORR:CSET:SAVE USER03
sense2:correction:cset:save user09
```

Query Syntax

SENSe<cnum>:CORRection:CSET:SAVE?
Inquire the correction file last stored.

Return Type

Char

Overlapping?

No

Default

NONE

Sense:Correction:Collect:Guided Commands

Perform and apply the guided measurement calibration and other error correction characteristic.

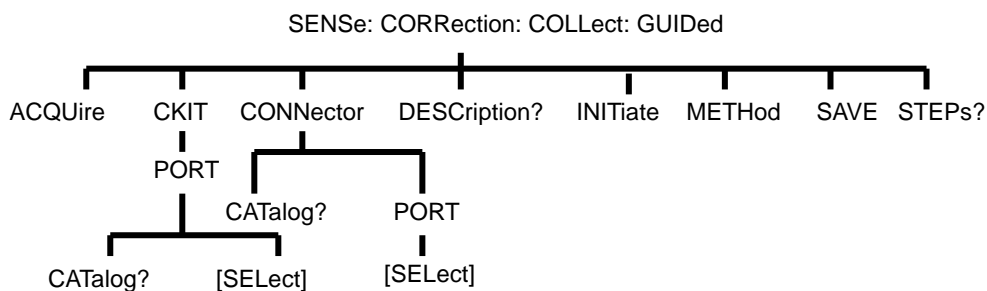

(Note: This command block is only valid for 4-port vector networks).

SENSe<cnum>:CORRection:COLlect:GUIDed:ACQUire <std>

(Write only) Initialize the measurement of the specified calibration standard. It will not function on the standards not needing to perform this command.

These measurement data is stored and will be used in the calculation of error correction coefficient, and the calibration is completed after completing all standard measurement. Before perform SENS:CORR:COLL:GUID:SAVE, any measurement can be performed repeatedly.

Use SENS:CORR:COLL:GUID:DESC? command to inquire user prompt instruction.

Use SENS:CORR:COLL:GUID:STEP? command to inquire required calibration step.

Parameter

<cnum>

Any existing channel number; if unspecified, set to 1.

<std>

Options are: STAN1, STAN2, STAN3, ...STAN40

Example

```
SENS:CORR:COLL:GUID:ACQ STAN1
sense2:correction:collect:guided:acquire stan1
```

Query Syntax NONE

Return Type Char

Overlapping? No

Default NONE

SENSe<cnum>:CORRection:COLLect:GUIDed:CKIT:PORT<pnum>:CATalog?

(Write only) Return the list of valid calibration kit of each port (separated by comma). Use SENS:CORR:COLL:GUID:CKIT:PORT command to select the calibration kit.

Parameter

<cnum> Any existing channel number; if unspecified, set to 1.

<pnum> Any existing port number: 1, 2 or 3 (for 3-Channel analyzer).
If unspecified, set to 1.

Example

```
SENS:CORR:COLL:GUID:CKIT:PORT1:CAT?
'If the connection type is "Type N (50) male", it returns:
"85054D, 85032F".
```

Return Type String

Overlapping? No

Default NONE

SENSe<cnum>:CORRection:COLLect:GUIDed:CKIT:PORT<pnum>[:SElect] <kit>

(Read-Write) Specify the calibration kit used by each port during guided calibration. It is not required to specify the calibration kit for the unused port.

Note:

1. Use SENS:CORR:COLL:GUID:CONN:PORT command to set the connection type of port.
2. Use SENS:CORR:COLL:GUID:CKIT:PORT:CAT? command to inquire the available calibration kit of each port.
3. Use this command to specify the calibration kit.
4. When using this command for query, if the parameter <kit> is inputted incorrectly, it will return an error message.

Parameter

<cnum> Any existing channel number; if unspecified, set to 1.

<pnum> Any existing port number: 1, 2 or 3 (for 3-port analyzers). If unspecified, set to 1.

<kit> Apply to the calibration kit of the specified port.

Example

```
SENS:CORR:COLL:GUID:CKIT:PORT1 '85055A'
```

```
sense2:correction:collect:ckit:port2:select '85055A'
```

Query Syntax SENSE:CORRection:COLLect:GUIDed:CKIT:PORT<pnum>[:SElect]?

Return Type String - If the parameter <kit> is inputted incorrectly, then it will return an error message.

Overlapping? No

Default NONE

SENSe<cnum>:CORRection:COLLect:GUIDed:CONNector:CATalog?

(Write only) Return a list of valid connector based on the description of the available calibration kit connector. Select an item from the returned list to specify the connector for SENS:CORR:COLL:GUID:CONN:PORT:SEL.

Example

```
SENS:CORR:COLL:GUID:CONN:CAT?
Return:
Type N (50) female, Type N (50) male, APC 7 (50), 3.5 mm (50) male, 3.5 mm (50) female, User Connector A
```

Return Type String

Overlapping? No

Default NONE

SENSe<cnum>:CORRection:COLLect:GUIDed:CONNector:PORT<pnum>[:SElect] <conn>

(Read-Write) Specify the connector type for each port during guided calibration. The name of valid connector is stored in the calibration kit. Some calibration kit may include male and female connector head, so it needs to specify the type of connector.

It must make a clear description on the unused port. If all ports are defined as "not available", then it can perform the guided calibration.

Single-port with a valid <conn> name indicates it will perform single-port calibration.

Dual-port with a valid <conn> name indicates it will perform dual-port calibration or or TRL calibration, depending on the standard definition of calibration kit and performance of analyzer. (For TRL calibration, the analyzer must have four receivers).

Tri-port with a valid <conn> name indicates it will perform 3-port calibration.

Note:

1. Before specifying the port connector, use SENS:CORR:COLL:GUID:CONN:CAT? command to inquire the valid connector.
2. Use this command to select the connector type.
3. When using this command for query, if parameter <conn> is inputted incorrectly, it will return the error message.
4. Use SENS:CORR:COLL:GUID:CKIT:PORT command to specify the calibration kit used for each port.

Parameter

<cnum> Any existing channel number; if unspecified, set to 1.

<pnum> Any existing port number: 1, 2 or 3 (3-port analyzer). If unspecified, set to 1.
 DUT connector type connected to the analyzer <pnum> port.
 Some calibration kit may have both male and female head connectors, which requires to specify the type of the corrector.

<conn> The name of valid connector is stored in the calibration kit. Use command `SENSe:CORRection:COLLect:GUIDed:CONNector:CATalog?` Inquire the valid connector.

Example

```
SENS:CORR:COLL:GUID:CONN:PORT1 'Type N (50) female'
'Indicating the DUT port connected to analyzer Port 1 is 'TypeN 50 Ohm female head connector'.
```

Query Syntax `SENSe<cnum>:CORRection:COLLect:GUIDed:CONNector:PORT<pnum>[:SElect]?`

Return Type String

Overlapping? No

Default NONE

SENSe<cnum>:CORRection:COLLect:GUIDed:DESCription? <step>

(Read only) Return the connection description of the specified calibration step.

Parameter

<cnum> Any existing channel number; if unspecified, set to 1.

<step> From 1 to any number within the step number required by calibration. (Use command `SENS:CORR:COLL:GUID:STEP?` to inquire step number)

Example

```
SENS:CORR:COLL:GUID:DESC ? 10
'Return
Connect APC 7 Open to port3.
```

Return Type String

Overlapping? No

Default NONE

SENSe<cnum>:CORRection:COLLect:GUIDed:INITiate

(Write only) Initiate a guided calibration via creating a new calibration kit.

The analyzer determines the setting used for perform standard measurement, which is specified by `SENS:CORR:COLL:GUID:CONN:PORT` and `SENS:CORR:COLL:GUID:CKIT:PORT`.

After perform this command, it can inquire the measurement step number via the subsequent

commands, then inquire the connection descriptive string and last complete the guided calibration.

Parameter

<cnm> Any existing channel number; if unspecified, set to 1.

Example

```
SENS:CORR:COLL:GUID:INIT
sense2:correction:collect:guided:initiate
```

Query Syntax NONE

Overlapping? No

Default NONE

SENSe<cnm>:CORRection:COLLEct:GUIDed:METhod <char>

(Read-Write) Select an available algorithm for guided calibration.

Parameter

<cnm> Any existing channel number; if unspecified, set to 1.

Note: To avoid error, please use the italicized part of the following <char> string, such as using UNKN other than UNKN*own*.

<char> **DEFAULT** - Inform the guided calibration to use default algorithm when calculating how many standard steps are required. (In this cases, the default algorithm is ADAPTER REMOVAL).

ADAPRemove - Use adaptor removal algorithm.

FLUSH - If ECal calibration set is specified, use FLUSH THRU algorithm. If the ECal calibration set is unused or the selected ECal mode is not embedded, then this option has no function.

UNKN*own* - It can useUnknown THRU algorithm for the 2-port calibration of non-embedded device. It can only function on the instrument with 4 receivers.

Example

```
SENS:CORR:COLL:GUID:METh
sense2:correction:collect:guided:method unkn
```

Query Syntax NONE

Overlapping? No

Default NONE

SENSe<cnm>:CORRection:COLLEct:GUIDed:SAVE

(Write only) Calculate the error correction item, turn on the calibration and store the calibration to the calibration set, thus ending the guided calibration. If it fails to measure all required standards, the calibration is not completed normally.

Parameter

<num> Any existing channel number; if unspecified, set to 1.

Example

```
SENS:CORR:COLL:GUID:SAVE
sense2:correction:collect:guided:save
```

Query Syntax NONE

Overlapping? No

Default NONE

SENSe<num>:CORRection:COLLect:GUIDed:STEPs?

(Read only) Return the measurement step number required by the current guided calibration. This command is sent after SENS:CORR:COLL:GUID:INIT, SENS:CORR:COLL:GUID:CONN:PORT and SENS:CORR:COLL:GUID:CKIT:PORT.

Parameter

<num> Any existing channel number; if unspecified, set to 1.

Example

```
SENS:CORR:COLL:GUID:STEP?
sense2:correction:collect:guided:steps?
```

Return Type Int

Overlapping? No

Default NONE

Sense:Couple Commands

SENSe<num>:COUPle <ALL | NONE>

(Read-Write) Set sweep mode to simultaneous or alternative sweep.

Parameter

<num> Any existing channel number; if unspecified, set to 1.

<ALL | NONE> | ALL - Simultaneous sweep -- reflection and transmission measurement are performed at the primary sweep.

NONE - Alternative sweep $\uparrow^a\downarrow^a$ reflection and transmission measurement are performed individually. It can improve the reflection of mixer and measurement of isolation, additionally increasing sweep time.

Example

```
SENS:COUP ALL
sense2:couple none
```

Query Syntax SENSE<cnum>:COUPle?

Return Type Char

Overlapping? No

Default ALL

Sense:Frequency Commands

Set the frequency sweep function for analyzer.

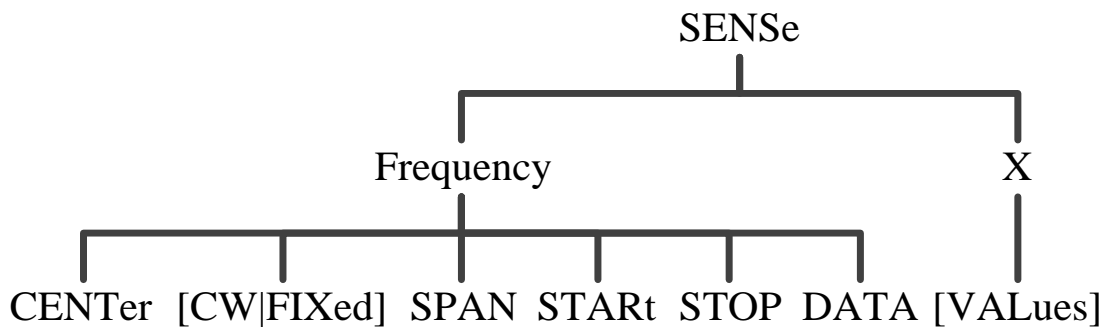

SENSE<cnum>:FREQUENCY:CENTer <num>

(Read-Write) Set the center frequency of analyzer.

Parameter

<cnum> Any existing channel number; if unspecified, set to 1.

<num> Center frequency. in the unit of Hz. Select any value between the MIN and MAX frequency of analyzer.

Note: This command will accept MIN or MAX instead of a numeric parameter. See SCPI Syntax for detail.

Example

```
SENS:FREQ:CENT 1000000
sense2:frequency:center 1mhz
```

Query Syntax SENSE<cnum>:FREQUENCY:CENTer?

Return Type Char

Overlapping? No

Default Center value of frequency span of analyzer.

SENSe<num>:FREQuency[:CW |:FIXed] <num>

(Read-Write) Set continuous wave (fixed) frequency. It must use SENS:SWEEP:TYPE CW command to set the analyzer sweep type to point frequency.

Parameter

<num> Any existing channel number; if unspecified, set to 1.

<num> Point frequency, in the unit of Hz. Select any value between the MIN and MAX frequency of analyzer.

Note: This command will accept MIN or MAX instead of a numeric parameter. See SCPI Syntax for detail.

Example

```
SENS:FREQ 1000000
SENS:FREQ:CW MIN
sense2:frequency:fixed 1mhz
```

Query Syntax SENSe<num>:FREQuency[:CW | :FIXed]?

Return Type Char

Overlapping? No

Default 2GHz

SENSe<num>:FREQuency:SPAN <num>

(Read-Write) Set the frequency span of analyzer.

Parameter

<num> Any existing channel number; if unspecified, set to 1.

<num> Frequency span. Value range: 0 (MIN) to MAX frequency of analyzer, in the unit of Hz. in the unit of Hz.

Note: This command will accept MIN or MAX instead of a numeric parameter. See SCPI Syntax for detail.

Example

```
SENS:FREQ:SPAN 1000000
sense2:frequency:span max
```

Query Syntax `SENSe<num>:FREQuency:SPAN?`

Return Type Char

Overlapping? No

Default Max frequency span of analyzer.

SENSe<num>:FREQuency:STARt <num>

(Read-Write) Set the start frequency of analyzer.

Parameter

<num> Any existing channel number; if unspecified, set to 1.

Start frequency. in the unit of Hz. Select any value between the MIN and MAX frequency of analyzer.

<num> Note: If `FREQ:START` value is larger than `FREQ:STOP`, then `STOP=START`.

Note: This command will accept MIN or MAX instead of a numeric parameter. See SCPI Syntax for detail.

Example

```
SENS:FREQ:STAR 1000000
sense2:frequency:start MIN
```

Query Syntax `SENSe<num>:FREQuency:STARt?`

Return Type Char

Overlapping? No

Default Min frequency of analyzer.

SENSe<num>:FREQuency:STOP <num>

(Read-Write) Set the stop frequency of analyzer.

Parameter

<num> Any existing channel number; if unspecified, set to 1.

Stop frequency. in the unit of Hz. Select any value between the MIN and MAX frequency of analyzer.

<num> Note: If `FREQ:STOP` value is lower than `FREQ:START`, then `START=STOP`.

Note: This command will accept MIN or MAX instead of a numeric parameter. See SCPI Syntax for detail.

Example

```
SENS:FREQ:STOP 1000000
sense2:frequency:stop max
```

Query Syntax SENSE<num>:FREQUENCY:STOP?

Return Type Char

Overlapping? No

Default Max frequency of analyzer.

SENSE<num>:FREQUENCY:DATA?

SENSE<num>:X:VALUES?]

(Read only) Equivalent command, inquire the incentive value of all measurement points.

Parameter

<num> Any existing channel number, If unspecified, default to 1.

Example

```
SENS2:FREQ:DATA?
sense:frequency:data?
SENS:X?
sense:x:values?
```

Query Syntax SENSE<num>:FREQUENCY:STOP?
SENSE<num>:X:VALUES?

Return Type Block data type. Specify the array data (frequency) of NOP (measurement point). Here n is an integer between 1 and NOP.

Data (n-1): frequency of the nth measurement point
Array index starts from 0.

Overlapping? No

Default Max frequency of analyzer

Sense:Power Commands

SENSE<num>:POWER:ATTENUATION <recvr>,<num>

(Read-Write) Set the attenuation value of receiver. (Determined by the instrument configuration)

Note: It cannot set the attenuation when the sweep type is power sweep.

Parameter

<num> Any existing channel number; if unspecified, set to 1.

<recvr> Receiver to be set with attenuation. Options:
ARECeiver - Receiver A

BRECeiver - Receiver B

Select (integer): 0 - 35 dB, with step of 5dB.

<num> If the input value is excluded, the analyzer will select the nearest min value. For example, when inputting 19dB, the analyzer will select 15dB.

Example

```
SENS:POW:ATT AREC,10
sense2:power:attenuation breceiver,30
```

Query Syntax SENSE<num>:POWER:ATTenuation? <rec>

Return Type Char

Overlapping? No

Default 0

Sense:Roscillator command**SENSe:ROSCillator:SOURce?**

(Read only) Read the connection status of reference signal.

EXT: the reference signal is provided by external signals.

INT: the reference signal is provided by internal signals.

Example

```
SENS:ROSC:SOUR?
sense:roscillator:source?
```

Return Type Char

Overlapping? No

Default NONE

Sense:Segment Commands

Define the segment sweep setting. Use SENS:SWE:TYPE SEGMENT command to stat segment sweep.

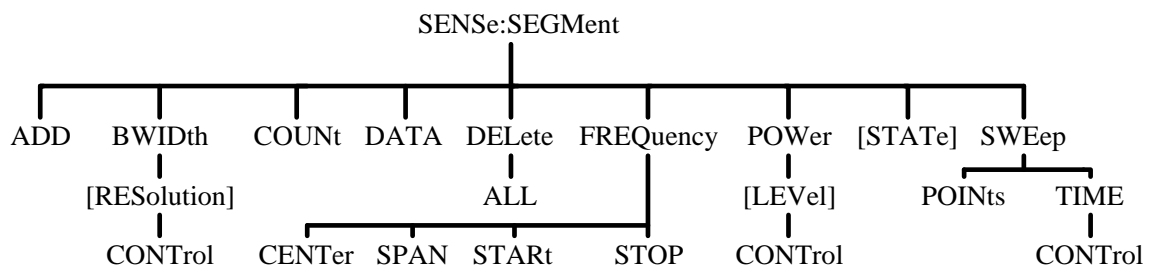

SENSe<cnum>:SEGMENT<snum>:ADD

(Write only) Add a segment.

Parameter

<cnum>	Any existing channel number; if unspecified, set to 1.
<snum>	Segment number to be added. If unspecified, set to 1. Segment number must in sequent order. If the segment number to be added is already exist, then the existing segment number and subsequent segment number will automatically add 1.

Example

There are two segments (1 and 2). Add a new segment (1) to the following command, then the original (1 and 2) segment will turn into (2 and 3) segment.

```
SENS:SEGM1:ADD
sense2:segment1:add
```

Query Syntax NONE. Use command Sense:Segment:Count to inquire the segment quantity in traces.

Overlapping? No

Default NONE

SENSe<cnum>:SEGMENT<snum>:BWIDth[:RESolution] <num>

(Read-Write) Set the IFBW of the specified segment. It first operates SENS:SEGM:BWIDth:CONTRol ON command to individually set the IFBW of the segment. All newly-added segment apply the new IFBW.

Parameter

<cnum>	Any existing channel number; if unspecified, set to 1.
<snum>	Segment number to be altered. Select any existing segment number.
<num>	IFBW, options: 1 2 3 5 7 10 15 20 30 50 70 100 150 200 300 500 700 1k 1.5k 2k 3k 5k 7k 10k 15k 20k 30k 35k 40k If the inputted value is excluded, then the analyzer will select the nearest value (if the inputted value is larger than the max in the list, then it selects the max). Note: This command will accept MIN or MAX instead of a numeric parameter. See SCPI Syntax for detail.

Example

```
SENS:SEGM:BWID 1KHZ
sense2:segment2:bwid:resolution max
```

Query Syntax SENSe<cnum>:SEGMENT<snum>:BWIDth[:RESolution]?

Return Type Char

Overlapping? No
 Default 35k

SENSe<cnum>:SEGMENT:BWIDth[:RESolution]:CONTRol <ON | OFF>

(Read-Write) Specify whether it can individually set the IFBW of each segment.

Parameter

<cnum> Any existing channel number; if unspecified, set to 1.
 <ON | OFF> ON (or 1) - Turn on, allow to set the IFBW of each segment.
 OFF (or 0) - Turn off, use the channel IFBW.

Example

```
SENS:SEGM:BWID:CONT ON
sense2:segment:bwid:control off
```

Query Syntax SENSe<cnum>:SEGMENT:BWIDth[:RESolution]:CONTRol?

Return Type Bool (1 = ON, 0 = OFF)

Overlapping? No
 Default OFF

SENSe<cnum>:SEGMENT:COUNt?

(Read only) Inquire the segment quantity existing in the specified channel.

Parameter

<cnum> Any existing channel number; if unspecified, set to 1.

Example

```
SENS:SEGM:COUNt?
sense2:segment:count?
```

Return Type Char

Overlapping? No
 Default 1

SENSe<cnum>:SEGMENT<snum>:DELete

(Write only) Select the specified sweep segment.

<cnun> Any existing channel number; if unspecified, set to 1.
 <snum> Segment number to be deleted. If unspecified, set to 1.

Example `SENS:SEGM:DEL
sense2:segment2:delete`

Query Syntax NONE

Overlapping? No

Default NONE

SENSe<cnun>:SEGMENT:DELeTE:ALL

(Write only) Delete all sweep segment.

Parameter

<cnun> Any existing channel number; if unspecified, set to 1.

Example `SENS:SEGM:DEL:ALL
sense2:segment:delete:all`

Query Syntax NONE

Overlapping? No

Default NONE

SENSe<cnun>:SEGMENT<snum>:FREQUENCY:CENTer <num>

(Read-Write) Set the center frequency for the specified segment, and the start and stop frequency will vary with it but the frequency span remains unchanged.

Note: If the start and stop frequency of all previous segments are larger than the new start frequency, then it uses the new frequency; if the start and stop frequency of all subsequent segments are lower than the new stop frequency, then it uses the new stop frequency.

Parameter

<cnun> Any existing channel number; if unspecified, set to 1.

<snum> Segment number to be altered. Select any existing segment number.

<num> Center frequency. in the unit of Hz. Choose any number between the minimum and maximum frequency of the analyzer.

Note: This command will accept MIN or MAX instead of a numeric parameter. See SCPI Syntax for detail.

Example	<code>SENS:SEGM:FREQ:CENT 1MHZ</code> <code>sense2:segment2:frequency:center 1e9</code>
Query Syntax	<code>SENSe<num>:SEGMent<snum>:FREQUency:CENTer?</code>
Return Type	Char
Overlapping?	No
Default	Stop frequency of last segment; For the first segment, it is the start frequency of analyzer.

SENSe<num>:SEGMent<snum>:FREQUency:SPAN <num>

(Read-Write) Set the frequency span for the specified segment. The center frequency of segment remains unchanged while the start and stop frequency vary with it.

Note: If the start and stop frequency of all previous segments are larger than the new start frequency, then it uses the new frequency; if the start and stop frequency of all subsequent segments are lower than the new stop frequency, then it uses the new stop frequency.

Parameter

<num>	Any existing channel number; if unspecified, set to 1.
<snum>	Segment number to be altered. Select any existing segment number.
<num>	Frequency span. in the unit of Hz. Choose any number between the minimum and maximum frequency of the analyzer. Note: This command will accept MIN or MAX instead of a numeric parameter. See SCPI Syntax for detail.

Example	<code>SENS:SEGM:FREQ:SPAN 1MHZ</code> <code>sense2:segment2:frequency:span max</code>
---------	--

Query Syntax	<code>SENSe<num>:SEGMent<snum>:FREQUency:SPAN?</code>
Return Type	Char
Overlapping?	No
Default	For the first segment, it is the frequency span of analyzer; otherwise, 0.

SENSe<num>:SEGMent<snum>:FREQUency:START <num>

(Read-Write) Set the start frequency for the specified sweep segment.

Note: If the start and stop frequency of any segments are larger than this frequency, then it uses this frequency.

Parameter

<cnm>	Any existing channel number; if unspecified, set to 1.
<snm>	Segment number to be altered. Select any existing segment number.
<num>	Start frequency. in the unit of Hz.Choose any number between the minimum and maximum frequency of the analyzer. Note: This command will accept MIN or MAX instead of a numeric parameter. See SCPI Syntax for detail.

Example

```
SENS:SEGM:FREQ:STAR 1MHZ
sense2:segment2:frequency:start minimum
```

Query Syntax SENSE<cnm>:SEGMent<snm>:FREQUency:STARt?

Return Type Char

Overlapping? No

Default Stop frequency of last segment; For the first segment, it is the start frequency of analyzer.

SENSe<cnm>:SEGMent<snm>:FREQUency:STOP <num>

(Read-Write) Set the stop frequency for the specified sweep segment.

Note: If the start and stop frequency of any segments are larger than this frequency, then it uses this frequency.

Parameter

<cnm>	Any existing channel number; if unspecified, set to 1.
<snm>	Segment number to be altered. Any existing segment number can be selected.
<num>	Stop frequency. in the unit of Hz.Choose any number between the minimum and maximum frequency of the analyzer. Note: This command will accept MIN or MAX instead of a numeric parameter. See SCPI Syntax for detail.

Example

```
SENS:SEGM:FREQ:STOP 1MHZ
sense2:segment2:frequency:stop maximum
```

Query Syntax SENSE<cnm>:SEGMent<snm>:FREQUency:STOP?

Return Type Char

Overlapping? No

Default For the first segment, it is the stop frequency of analyzer; otherwise the start frequency of this segment.

SENSe<cnum>:SEGMENT<snum>:POWer[<port>][:LEVel] <num>

(Read-Write) Set port power level for the specified sweep point. It first uses SENS:SEGM:POW:CONTRol ON command to allow to set the power level of segment. All newly-added segment will use the new level.

Parameter

<cnum>	Any existing channel number; if unspecified, set to 1.
<snum>	Segment number to be altered. Select any existing segment number.
<port>	Source port number. 1 or 2, if unspecified, set to 1.
<num>	Power level. The optional value is between: -90 - 20 (depending on the power level range of analyzer)

Example

```
SENS:SEGM:POW 0
sense2:segment2:power1:level -10
```

Query Syntax SENSE<cnum>:SEGMENT<snum>:POWer[<port>][:LEVel]?

Return Type Char

Overlapping? No

Default 0

SENSe<cnum>:SEGMENT:POWer[:LEVel]:CONTRol <ON | OFF>

(Read-Write) Whether it can independently set the power level of each segment.

Parameter

<cnum>	Any existing channel number; if unspecified, set to 1.
<ON OFF>	ON (or 1) - Allow. Each segment can independently set the power level. OFF (or 0) - Forbid. Use the power level of channel.

Example

```
SENS:SEGM:POW:CONT ON
sense2:segment:power:level:control off
```

Query Syntax SENSE<cnum>:SEGMENT:POWer[:LEVel]:CONTRol?

Return Type Bool (1 = ON, 0 = OFF)

Overlapping? No

Default OFF

SENSe<cnum>:SEGMENT<snum>[:STATe] <ON | OFF>

(Read-Write) Turn on or off the sweep segment.

Parameter

<cnum>	Any existing channel number; if unspecified, set to 1.
<snum>	Segment number.
<ON OFF>	ON (or 1) - Turn on segment. OFF (or 0) - Turn off segment.

Example

```
SENS:SEGM ON
sense2:segment2:state off
```

Query Syntax SENSE<cnum>:SEGMENT[:STATe]? <snum>

Return Type Bool (1 = ON, 0 = OFF)

Overlapping? No

Default OFF

SENSe<cnum>:SEGMENT<snum>:SWEep:POINTs <num>

(Read-Write) Set sweep point for the specified sweep segment.

Parameter

<cnum>	Any existing channel number; if unspecified, set to 1.
<snum>	Any existing segment number. If unspecified, set to 1.
<num>	Segment sweep point number. The sum of point number of all segments should not exceed 16001. Each segment has 1 point at minimum. Note: This command will accept MIN or MAX instead of a numeric parameter. See SCPI Syntax for detail.

Example

```
SENS:SEGM:SWE:POIN 51
sense2:segment2:sweep:points maximum
```

Query Syntax SENSE<cnum>:SEGMENT<snum>:SWEep:POINTs?

Return Type Char

Overlapping? No

Default 201

SENSe<cnm>:SEGMENT<snum>:SWEep:TIME <num>

(Read-Write) Set the sweep time of the specified sweep segment of analyzer.

Parameter

<cnm>	Any existing channel number; if unspecified, set to 1.
<snum>	Any existing segment number.
<num>	Sweep time, in the unit of s. Value range: 0 - 100 Note: This command will accept MIN or MAX instead of a numeric parameter. See SCPI Syntax for detail.

Example

```
SENS:SEGM:SWE:TIME 1ms
sense2:segment2:sweep:time .001
```

Query Syntax SENSE<cnm>:SEGMENT<snum>:SWEep:TIME?

Return Type Char

Overlapping? No

Default NONE

SENSe<cnm>:SEGMENT:SWEep:TIME:CONTROL <ON | OFF>

(Read-Write) Specify whether it can independently set the sweep time of each segment.

Parameter

<cnm>	Any existing channel number; if unspecified, set to 1.
<ON OFF>	ON (or 1) - Allow. It can independently make setting. OFF (or 0) - Forbid. Use channel sweep time.

Example

```
SENS:SEGM:SWE:TIM:CONT ON
sense2:segment:sweep:time:control off
```

Query Syntax SENSE<cnm>:SEGMENT:SWEep:TIME:CONTROL?

Return Type Bool (1 = ON, 0 = OFF)

Overlapping? No

Default OFF

SENSe<cnm>:SEGMENT:DATA <block>

(Read-Write) Set or get the segment sweep point of the specified channel.

Note: This command is compatible with the programming commands of Agilent ENA series vector network analyzer. Only available for 1.2.0 and above.

Parameter

<cnm> Any existing channel number, If unspecified, default to 1.

Block data. Data structure is as follows:

N is the segment number (specified by <segm>), which is an integer between 1 and N.

Data = {<buf>, <stim>, <ifbw>, <pow>, , <swp>, <time>, <segm>, <star 1>, <stop 1>, <nop 1>, <ifbw 1>, <pow 1>, <del 1>, <swp 1>, <time 1>, ..., <star n>, <stop n>, <nop n>, <ifbw n>, <pow n>, <del n>, <swp n>, <time n>, ..., <star N>, <stop N>, <nop N>, <ifbw N>, <pow N>, <del N>, <swp N>, <time N>}

In the formula:

<buf>*: always specify to 5 or 6. If set the sweep mode for each segment, it must specify 6. (Not supporting independently setting sweep mode temporarily)

<stim>: stimulus setting mode.

0: specify via start/stop value

1: specify via center/width value

<ifbw>: turn on/off IFBW setting of each segment. 0: turn off, 1: turn on.

<pow>: turn on/off power setting of each segment. 0: turn off, 1: turn on.

*: turn on/off sweep delay time setting of each segment. 0: turn off, 1: turn on. (Not supporting this parameter temporarily; if set to 1, ignored)

<swp>: turn on/off sweep mode setting of each segment. 0: turn off, 1: turn on.

When <buf> is 5, unnecessary.

<time>: turn on/off sweep time setting of each segment. 0: turn off, 1: turn on.

<segm>: segment number

<block> Specify an integer between 0 to 100 (set to 0 or 100 if exceeding this range).

<star n>: start/center value of the nth segment.

<stop n>: stop/width value of the nth segment.

<nop n>: measurement point number of the nth segment.

<ifbw n>: when the IFBW setting of each segment is off (<ifbw>: 0), not needing the IFBW of the nth segment.

<pow n>: when the power setting of each segment is off (<pow>: 0), not needing the power of the nth segment.

<del n>*: when the sweep delay time setting of each segment is off (: 0), not needing the sweep delay time of the nth segment.

<swp n>*: the sweep mode of the nth segment is stepped mode, swept mode, stepping mode and swept mode.

0: Stepped mode

1: Swept mode

2: Stepped mode

3: Swept mode

When <buf> is 5 or the sweep mode setting of each segment is off (<swp>: 0), unnecessary.

<time n>: when the sweep time setting of each segment is off (<time>: 0), not needing the sweep time of the nth segment.

Example

```
SENS1:SEGM:DATA 5,0,1,0,0,0,3, // Instruction: create a segment sweep table having 3 segments, with each segment independently setting the center frequency.
```

```
1e5,1e9,11,7e3, //Instruction: the 1nd segment, having frequency range of
100kHz~1GHz, sweep point number of 11 and IFBW of 70kHz.
1e9,2e9,51,7e3, //Instruction: the 2nd segment, having frequency range of 1GHz~2GHz,
sweep point number of 51 and IFBW of 7kHz.
2e9,3e9,11,7e3, //Instruction: the 3rd segment, having frequency range of 2GHz~3GHz,
sweep point number of 11 and IFBW of 70kHz.
```

Query Syntax SENSE<num>:SEGMENT:DATA?

Return Type Block

Overlapping? No

Default NONE

Sense:Sweep Commands

Set the sweep function of analyzer.

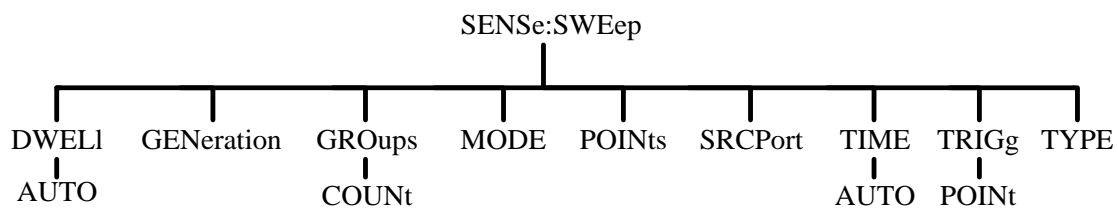

SENSE<num>:SWEep:DWELI <num>

(Read-Write) Set the dwell time between two sweep points.

Only when SENSE:SWEep:GENeration is set to STEPped, dwell time is valid; set to ANALOG, invalid.

Set dwell = 0, equivalent to automatically perform SENSE:SWE:DWEL:AUTO ON. If dwell time >0, equivalent to automatically perform SENSE:SWE:DWEL:AUTO OFF.

Parameter

<num> Any existing channel number; if unspecified, set to 1.

Dwell time, in the unit of s.

<num> Note: This command will accept MIN or MAX instead of a numeric parameter. See SCPI Syntax for detail.

Example

```
SENS:SWE:DWEL .1
sense2:sweep:dwell min
```

Query Syntax SENSE<num>:SWEep:DWELI?

Return Type Char

Overlapping? No

Default 0 - (Note: It is equivalent to dwell:auto ON when dwell time is set to 0)

SENSe<cnm>:SWEep:DWEL:AUtO <ON | OFF>

(Read-Write) Specify whether automatically calculate and set the possible minimum dwell time. It is equivalent to dwell time=0 when set to ON.

Parameter

<cnm> Any existing channel number; if unspecified, set to 1.

<ON | OFF> ON (or 1) - On.
OFF (or 0) - Off.

Example

```
SENS:SWE:DWEL:AUTO ON
sense2:sweep:dwell:auto off
```

Query Syntax SENSe<cnm>:SWEep:DWEL:AUtO?

Return Type Bool (1 = ON, 0 = OFF)

Overlapping? No

Default ON

SENSe<cnm>:SWEep:GENeration <char>

(Read-Write) Set sweep mode to stepped or analog mode.

Parameter

<cnm> Any existing channel number; if unspecified, set to 1.

<char> Options:
STEPped (Stepped sweep mode) - Source power remains unchanged when measuring each point, achieving accurate measurement. It can set the dwell time under this mode.
ANALog (Analog sweep mode) - Source power varies with slope when measuring each point, achieving fast measurement speed. It can set sweep time under this mode (non-dwell time).

Example

```
SENS:SWE:GEN STEP
sense2:sweep:generation analog
```

Query Syntax SENSe<cnm>:SWEep:GENeration?

Return Type Char

Overlapping? No

Default Analog

SENSe<cnm>:SWEep:GROups:COUNT <num>

(Read-Write) Set the group trigger times for the specified channel.

Parameter

<cnm> Any existing channel number; if unspecified, set to 1.

<num> Group trigger times. Range:
1 - 2e6
(Equivalent to single trigger when set to 1)

Example

```
SENS:SWE:GRO:COUN 10
sense2:sweep:groups:count 50
```

Query Syntax SENSe<cnm>:SWEep:GROups:COUNT?

Return Type Char

Overlapping? No

Default 1

SENSe<cnm>:SWEep:MODE <char>

(Read-Write) Set trigger mode for the specified channel.

Parameter

<cnm> Any existing channel number; if unspecified, set to 1.

<char> Trigger mode. Options:
HOLD - Hold
CONTInuous - Continuous trigger
GROups - Channel receives the specified trigger times, which are specified by the last sent SENS:SWE:GRO:COUN <num> command.

Example

```
SENS:SWE:MODE CONT
sense2:sweep:mode hold
```

Query Syntax SENSe<cnm>:SWEep:MODE?

Return Type Char

Overlapping?	Yes - SENS:SWE:MODE GROUPS (when INIT:CONT is ON) No - HOLD and CONTInuous
Default	CONTInuous

SENSe<cnum>:SWEep:POINts <num>

(Read-Write) Set number of measurement points.

Parameter

<cnum>	Any existing channel number; if unspecified, set to 1. Value range: 1 - 16001
<num>	Note: This command will accept MIN or MAX instead of a numeric parameter. See SCPI Syntax for detail.

Example

```
SENS:SWE:POIN 51
sense2:sweep:points max
```

Query Syntax SENSE<cnum>:SWEep:POINts?

Return Type Char

Overlapping? No

Default 201

SENSe<cnum>:SWEep:SRCPort <1 | 2>

(Read-Write) Set the source port during non S-Parameter measurement, without affecting measurement of S-Parameter.

Parameter

<cnum>	Any existing channel number; if unspecified, set to 1.
<1 2>	1 - Source port 1 2 - Source port 2

Example

```
SENS:SWE:SRCP 1
sense2:sweep:srcport 2
```

Query Syntax SENSE<cnum>:SWEep:SRCPort?

Return Type Char

Overlapping? No

Default 1

SENSe<cnum>:SWEep:TIME <num>

(Read-Write) Set the sweep time required for primary sweep by analyzer.

Parameter

<cnum> Any existing channel number; if unspecified, set to 1.

<num> Sweep time, in the unit of s. Value range is from 0 - 86,400 (24h)
 Note: This command will accept MIN or MAX instead of a numeric parameter. See SCPI Syntax for detail.

Example

```
SENS:SWE:TIME 1ms
sense2:sweep:time .001
```

Query Syntax SENSE<cnum>:SWEep:TIME?

Return Type Char

Overlapping? No

Default NONE

SENSe<cnum>:SWEep:TIME:AUTO <ON | OFF>

(Read-Write) Turn on or off automatic sweep time calculation function.

Parameter

<cnum> Any existing channel number; if unspecified, set to 1.

<ON | OFF> ON (or 1) - Turn on automatic sweep time.
 OFF (or 0) - Turn off automatic sweep time.

Example

```
SENS:SWE:TIME:AUTO
sense2:sweep:time:auto off
```

Query Syntax SENSE<cnum>:SWEep:TIME:AUTO?

Return Type Bool (1 = ON, 0 = OFF)

Overlapping? No

Default ON

SENSe<num>:SWEep:TRIGger:POINT <ON | OFF>

(Read-Write) Set trigger mode for the specified channel. (Read-Write) Set to measure a point or all points on channel upon each trigger. When any channel is set to POINT mode, it will automatically set TRIGger:SCOPE = CURRENT.

Parameter

<num> Any existing channel number; if unspecified, set to 1.
 <ON | OFF> ON (or 1) - Measure a sweep point upon each trigger.
 OFF (or 0) - Measure all points on channel upon each trigger.

Example

```
SENS:SWE:TRIG:POIN ON
sense2:sweep:trigger:point off
```

Query Syntax SENSE<num>:SWEep:TRIGger:POINT?

Return Type Bool (1 = Point, 0 = Measurement)

Overlapping? No

Default 0 - Measurement

SENSe<num>:SWEep:TYPE <char>

(Read-Write) Set the sweep type of analyzer.

Parameter

<num> Any existing channel number; if unspecified, set to 1.
 Options:
 <char> LINear | LOGarithmic | POWer | CW | SEGMENT
 Note: When the analyzer starts operation, it will turn on a segment automatically.

Example

```
SENS:SWE:TYPE LIN
sense2:sweep:type segment
```

Query Syntax SENSE<num>:SWEep:TYPE?

Return Type Char

Overlapping? No

Default LINear

Service Commands

Get the instrument software version, trace number, window number and channel number control

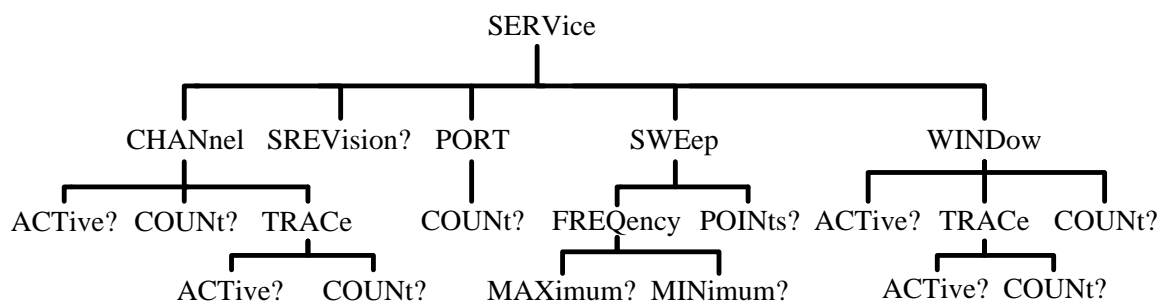

SERVice:CHANnel<cnun>:TRACe:ACTive?

(Read only) Read the index of active trace of selected channel <cnun>.

Note: In AV3656A, owing to the same channel can be displayed simultaneously in several windows, it can have several active traces.

Parameter

<cnun> Channel number. Integer, with the range of 1 to 64.

Example `SERV:CHAN1:TRAC:ACT?`

Query Syntax `SERVice:CHANne<cnun>:TRACe:ACTive?`

Return Type `Char[,Char,Char,... ...]`

Overlapping? No

Default NONE

SERVice:WINDow<wnun>:TRACe:ACTive?

(Read only) Read the number of active traces in the specified window <wnun>.

Parameter

<wnun> Window number. Integer, with the range of 1 to 32.

Example `SERV:WIND2:TRAC:ACT?`

Query Syntax `SERVice:WINDow<wnun>:TRACe:ACTive?`

Return Type `Char`

Overlapping? No

Default NONE

SERvice:CHANnel:ACTive?

(Read only) Read the active channel number.

Example `SERV:CHAN:ACT?`

Query Syntax `SERvice:CHANnel:ACTive?`

Return Type Char

Overlapping? No

Default NONE

SERvice:WINDow:ACTive?

(Read only) Read the active window number.

Example `SERV:WIND:ACT?`

Query Syntax `SERvice:WINDow:ACTive?`

Return Type Char

Overlapping? No

Default NONE

SERvice:CHANnel:COUNt?

(Read only) Read the upper limit of AV3656A channel number.

Example `SERV:CHAN:COUN?`

Query Syntax `SERvice:CHANnel:COUNt?`

Return Type Char

Overlapping? No

Default NONE

SERvice:WINDow:COUNt?

(Read only) Read the upper limit of AV3656A window number.

Example `SERV:WIND:COUN?`

Query Syntax `SERVice:WINDow:COUNT?`

Return Type Char

Overlapping? No

Default NONE

SERVice:CHANnel:TRACe:COUNT?

(Read only) Read the upper limit of each channel trace number.

Note: In AV3656A, a channel may have (maximum window number X maximum trace number in each window) traces at maximum.

Example `SERV:CHAN:TRAC:COUN?`

Query Syntax `SERVice:CHANnel:TRACe:COUNT?`

Return Type Char

Overlapping? No

Default NONE

SERVice:WINDow:TRACe:COUNT?

(Read only) Read the upper limit of each window trace number.

Example `SERV:WIND:TRAC:COUN?`

Query Syntax `SERVice:WINDow:TRACe:COUNT?`

Return Type Char

Overlapping? No

Default NONE

SERVice:PORT:COUNT?

(Read only) Read the AV3656A port number.

Example `SERVice:PORT:COUNT?`

Query Syntax `SERVice:PORT:COUNt?`

Return Type Char

Overlapping? No

Default NONE

SERVice:SREVision?

(Read only) Read the AV3656A system technical specification version.

Example `SERV:SREV?`

Query Syntax `SERVice:SREVisionz`

Return Type Char
For example: "No.: 10206, Show Ver.: 100"

Overlapping? No

Default NONE

SERVice:SWEep:FREQency:MAXimum?

(Read only) Read the upper limit of AV3656A measurement frequency.

Example `SERV:SWE:FREQ:MAX?`

Query Syntax `SERVice:SWEep:FREQency:MAXimum?`

Return Type Char

Overlapping? No

Default NONE

SERVice:SWEep:FREQency:MINimum?

(Read only) Read the lower limit of AV3656A measurement frequency.

Example `SERV:SWE:FREQ:MIN?`

Query Syntax `SERVice:SWEep:FREQency:MINimum?`

Return Type Char

Overlapping? No
 Default NONE

SERvice:SWEep:POINts?

(Read only) Read the upper limit of measurement point of the current configuration.

Example `SERV:SWE:POIN?`

Query Syntax `SERvice:SWEep:POINts?`

Return Type Char

Overlapping? No

Default NONE

Source Commands

Control the power to DUT.

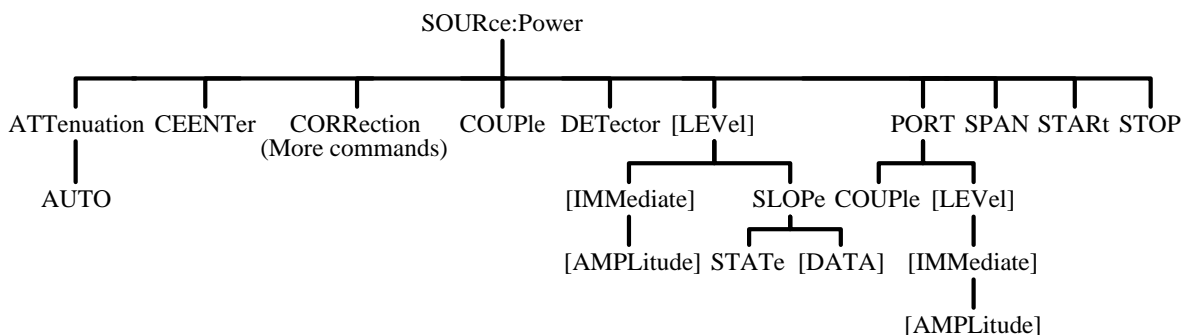

SOURce<num>:POWer<port>:ATTenuation <num>

(Read-Write) Set the attenuation values for the selected channel. If the port is coupled, then the attenuation value of a port varies with the changes of that of other ports. It can turn off the port coupling by using `SOURce:POWer:COUple OFF` command.

Parameter

<num> Any existing channel number; if unspecified, set to 1.

<port> Port number to be set with attenuation. Choose 1 or 2; if unspecified, default to 1.

Value range: 0 - 70 dB, with 10dB step.

<num> If the value entered is not a multiple of 10, then it takes the closest value. For example: if value <num> 19 is entered, then the analyzer value is 20dB.

Note: This command receives MIN and MAX parameters. See SCPI Syntax for detail.

Example SOUR:POW:ATT 10
 source2:power:attenuation maximum

Query Syntax SOURce<cnum>:POWer<port>:ATTenuation?

Return Type Char

Overlapping? No

Default 0

SOURce<cnum>:POWer<port>:ATTenuation:AUTO <ON | OFF>

(Read-Write) Turn on or off automatic attenuation.

Parameter

<cnum> Any existing channel number; if unspecified, set to 1.

<port> Port number to be set with attenuation. Choose 1 or 2; if unspecified, default to 1.

<ON | OFF> ON (or 1) - Automatic attenuation. Analyzer automatically selects the attenuation values for the specified power level.
 OFF (or 0) - Manual attenuation. It must use SOURce:POWer:ATTenuation <num> command to set attenuation value.

Example SOUR:POW2:ATT:Auto On
 source2:power:attenuation:auto off

Query Syntax SOURce<cnum>:POWer:ATTenuation:Auto?

Return Type Bool (1 = ON, 0 = OFF)

Overlapping? No

Default ON

SOURce<cnum>:POWer:CENTer <num>

(Read-Write) Set the center power of power sweep. At the same time, it should use SENS:SWE:TYPE POWER command to set the power sweep type, and SOURce:POWer:SPAN <num> command to set the power sweep bandwidth.

Parameter

<cnum> Any existing channel number; if unspecified, set to 1.

<num> Center power. Value range: -85 - 20dBm (depending on the specific instrument model).
 (The actual achievable power depends on the frequency)

Example

```
SOUR:POW:CENT -15
source2:power:center -7
```

Query Syntax SOURce<cnum>:POWer:CENTer?

Return Type Char

Overlapping? No

Default 0dBm

SOURce<cnum>:POWer:COUPlE <ON | OFF>

(Read-Write) Turn on or off port coupling function.

Parameter

<cnum> Any existing channel number; if unspecified, set to 1.

<ON | OFF> ON (or 1) - Turn on coupling. Two source ports use the same power level.
 OFF (or 0) - Turn off coupling. Set power level for each source port number.

Example

```
SOUR:POW:COUP ON
source2:power:couple off
```

Query Syntax SOURce<cnum>:POWer:COUPlE?

Return Type Bool (1 = ON, 0 = OFF)

Overlapping? No

Default ON

SOURce<cnum>:POWer:DETector <INTernal | EXTernal>

(Read-Write) Set the loop circuit of source fixed-amplitude to internal or external detection.

Parameter

<cnum> Any existing channel number; if unspecified, set to 1.

<INTernal | EXTernal> INTernal - Loop circuit of source fixed-amplitude uses internal detection.
 EXTernal - External detection, input via the rear panel interface.

Example

```
SOUR:POW:DET INT
source2:power:detector external
```

Query Syntax `SOURce<cnum>:POWer:DETEctor?`

Return Type Char

Overlapping? No

Default INTernal

`SOURce<cnum>:POWer<port>[:LEVel][:IMMediate][:AMPLitude] <num>`

(Read-Write) Set the radio frequency output level.

Parameter

<cnum> Any existing channel number; if unspecified, set to 1.

<port> Port number to be set with attenuation. Choose 1 or 2; if unspecified, default to 1.

<num> Source power, in the unit of dBm. Value range: -85 - +20dBm (depending on the specific instrument model).

(The actual achievable power depends on the frequency)

Note: This command receives MIN and MAX parameters. See SCPI Syntax for detail.

Example

```
SOUR:POW1 5dBm
source2:power:level:immediate:amplitude maximum
```

Query Syntax `SOURce<cnum>:POWer[:LEVel][:IMMediate][:AMPLitude]?`

Return Type Char

Overlapping? No

Default 0dBm

`SOURce<cnum>:POWer[:LEVel]:SLOPe <int>`

(Read-Write) Set the radio frequency slope value.

Parameter

<cnum> Any existing channel number; if unspecified, set to 1.

<int> Slope, in the unit of dB/GHz. Value range: -2.0 - 2.0, step distance: 0.5dB/GHz. (0 represents no slope).

Example

```
SOUR:POW:SLOP 2
source2:power:slope -2
```

Query Syntax `SOURce<cnum>:POWer[:LEVel]:SLOPe?`

Return Type Char

Overlapping? No

Default 0

SOURce<cnum>:POWer[:LEVel]:SLOPe:STATe <ON|OFF>

(Read-Write) Turn on or off power slope.

Parameter

<cnum> Any existing channel number; if unspecified, set to 1.

<ON|OFF> ON (or 1) - Turn on power slope.
OFF (or 0) - Turn off power slope.

Example

```
SOUR:POW:SLOP:STAT ON
source2:power:slope:state off
```

Query Syntax `SOURce<cnum>:POWer[:LEVel]:SLOPe:STATe?`

Return Type Bool (1 = ON, 0 = OFF)

Overlapping? No

Default OFF

SOURce<cnum>:POWer:SPAN <num>

(Read-Write) Set the frequency bandwidth during power sweep. At the same time, it should use `SENS:SWE:TYPE POWER` command to set the power sweep type, and `SOURce:POWer:CENTer <num>` command to set the power sweep bandwidth.

Parameter

<cnum> Any existing channel number; if unspecified, set to 1.

<num> Power bandwidth. Value range: -85 - 20dBm (depending on the specific instrument model)
(The actual achievable power depends on the frequency)

Example

```
SOUR:POW:SPAN -15
source2:power:span -7
```

Query Syntax `SOURce<cnum>:POWer:SPAN?`

Return Type Char

Overlapping? No

Default 0dBm

SOURce<cnum>:POWer:STARt <num>

(Read-Write) Set the start power during power sweep. At the same time, it should use SENS:SWE:TYPE POWER command to set the power sweep type, and SOURce:POWer:STOP <num> command to set the stop power.

Parameter

<cnum> Any existing channel number; if unspecified, set to 1.

<num> Start power. Value range: -85 - +20dBm
(The actual achievable power depends on the frequency)

Example

```
SOUR:POW:STAR -15
source2:power:start -7
```

Query Syntax SOURce<cnum>:POWer:STARt?

Return Type Char

Overlapping? No

Default 0dBm

SOURce<cnum>:POWer:STOP <num>

(Read-Write) Set the stop power during power sweep. At the same time, it should use SENS:SWE:TYPE POWER command to set the power sweep type, and SOURce:POWer:START <num> command to set the start power.

Parameter

<cnum> Any existing channel number; if unspecified, set to 1.

<num> Stop power. Value range: -85 - +20dBm (depending on the specific instrument model).
(The actual achievable power depends on the frequency)

Example

```
SOUR:POW:STOP -15
source2:power:stop -7
```

Query Syntax SOURce<cnum>:POWer:STOP?

Return Type Char

Overlapping? No

Default 0dBm

The above commands are available in 1.2.0 or above programs.

SOURce<num>:POWer[:LEVel]:SLOPe[:DATA] <int>

(Read-Write) Set radio frequency port output power.

Parameter

<num> Any existing channel number; if unspecified, default to 1.

<int> Slope, in the unit of dB/GHz. Value range: -2.0 - 2.0, step distance: 0.5dB/GHz.
(0 represents no slope).

Example

```
SOUR:POW:SLOP 2
source2:power:slope -2
```

Query Syntax SOURce<num>:POWer[:LEVel]:SLOPe?

Return Type Char

Overlapping? No

Default value 0

SOURce<num>:POWer:PORT:COUPle <ON|OFF>

(Read-Write) Turn on or off port coupling function.

Parameter

<num> Any existing channel number; if unspecified, default to 1.

<ON | OFF> ON (or 1) - Turn on coupling. Two source ports use the same power level.
OFF (or 0) - Turn off coupling. Set power level for each source port number.

Example

```
SOUR:POW:COUP ON
source2:power:couple off
```

Query Syntax SOURce<num>:POWer:COUPle?

Return Type Bool (1 = ON, 0 = OFF)

Overlapping? No
 Default ON

SOURce<cnUm>:POWer:PORT<port>[:LEVel][:IMMediate][:AMPLitude] <num>

(Read-Write) Get/set the power level of the specified port.

Parameter

<cnUm> Any existing channel number; if unspecified, default to 1.
 <port> Port number to be set with attenuation. Choose 1 or 2; if unspecified, default to 1.
 <num> Source power, in the unit of dBm. Value range: -85 - +20dBm (depending on the specific instrument model).
 (The actual achievable power depends on the frequency)
 Note: This command receives MIN and MAX parameters. See SCPI Syntax.

Example `SOUR:POW1 5dBm`
`source2:power:level:immediate:amplitude maximum`

Query Syntax `SOURce<cnUm>:POWer[:LEVel][:IMMediate][:AMPLitude]?`

Return Type Char

Overlapping? No
 Default 0dBm

Source:Power:Correction Commands

Provide the source power calibration function of VNA.

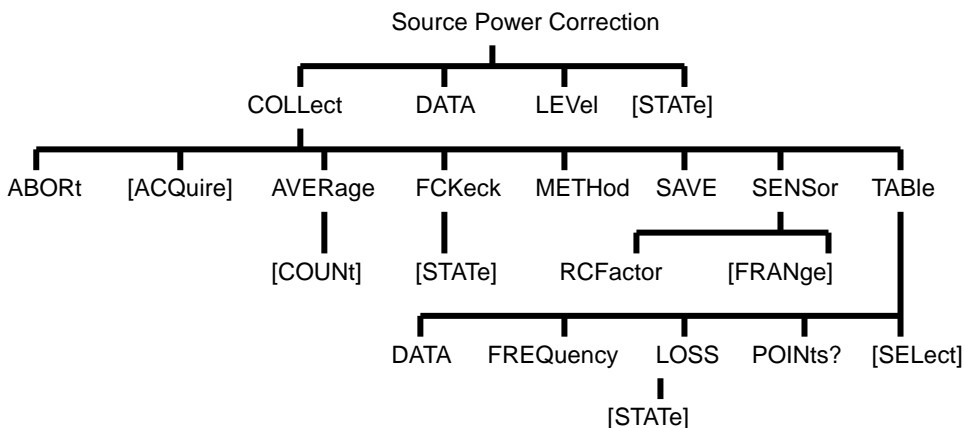

Note: The below commands available in 1.2.0 or above.

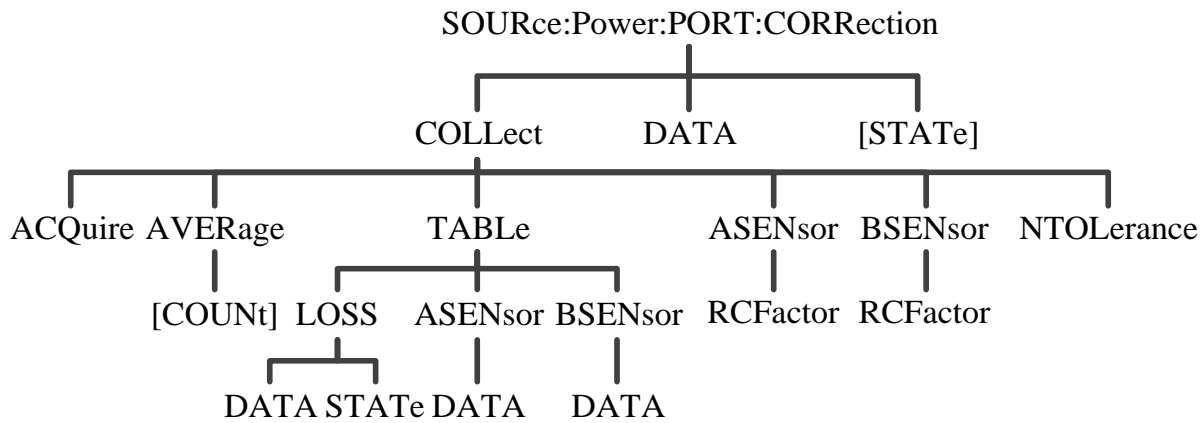

(Note: Commands of this command block are not provided temporarily)

Note: SOURce:POWER:CORRection:COLLECT:ACQuire command (which is used to make the network analyzer in a step sweep mode and read the data from the power meter. If the power meter does not use an additional GPIB interface, it can not send this command via GPIB). See the details of the command.

SOURce<cnUm>:POWER<port>:CORRection:COLLECT:ABORt

(Write only) Abort the source power calibration sweep in operation.

Parameter

<cnUm> Any existing channel number; if unspecified, set to 1.

<port> Port number to perform source power calibration. If unspecified, set to 1.

Example

```
SOUR:POW:CORR:COLL:ABOR
source1:power2:correction:collect:abort
```

Query Syntax NONE

Overlapping? No

Default NONE

SOURce<cnUm>:POWER<port>:CORRection:COLLECT[:ACQuire] <char>

(Write only) Initialize the source power calibration sweep by using the power meter sensor connected to the specified power meter channel (A or B).

Note: It cannot use GPIB to send this SCPI commands to analyzer (unless the power meter uses the additional GPIB interface). The command requires the analyzer to obtain GPIB control, but the analyzer currently does not support the controller transfer technology between two controllers.

It can use one of the following methods to perform this command or its equivalent:

Perform the SCPI programming of network analyzer via LAN client.

Send SCPI commands via COM interfaces.

Directly control the power meter and network analyzer, then get and store the power meter readings using step frequency. (See Example)

Parameter

<cnm>	Any existing channel number; if unspecified, set to 1.
<port>	Port number to perform source power calibration. If unspecified, set to 1.
<char>	Select: ASENsor - Power sensor on power meter channel A. BSENsor - Power sensor on power meter channel B.

Example

```
SOUR:POW:CORR:COLLASEN
source1:power2:correction:collect:acquire bsensor
```

Query Syntax NONE

Overlapping? No

Default NONE

SOURce<cnm>:POWER<port>:CORRection:COLLect:AVERage[:COUNT] <num>

(Read-Write) Set the number of power reads (i.e. average factor) of each frequency point during source power calibration sweep.

Parameter

<cnm>	Any existing channel number; if unspecified, set to 1.
<port>	Port number to perform source power calibration. If unspecified, set to 1.
<num>	Number of each point read, in the range: 1 to 100.

Example

```
SOUR:POW:CORR:COLL:AVER 2
source1:power2:correction:collect:average:count 3
```

Query Syntax SOURce:POWER:CORRection:COLLect:AVERage[:COUNT]?

Return Type Char

Overlapping? No

Default 1

SOURce<cnm>:POWER:CORRection:COLLect:FCHeck[:STATe] <ON | OFF>

(Read-Write) Set to turn on or off the frequency check during source power calibration sweep.

Parameter

<cnum>	Any existing channel number; if unspecified, set to 1.
<ON OFF>	<p>ON (1) - Turn on the frequency check. Only when the frequency point frequency to be swept is within the rated frequency range of power sensor, the data collected is effective. If the frequency point frequency to be swept exceeds the rated frequency range of power sensor, it will suspend the data collection. At this point, the sensor connected to the other input channel of power meter replaces the original ones to complete the subsequent measurement.</p> <p>Of course, the rated frequency of the second sensor must be sufficient to complete the sweep. Use <code>SOURce<cnum>:POWer:CORRection:COLLect:ASENSor[:FRANge]</code> and <code>SOURce<cnum>:POWer:CORRection:COLLect:BSENSor[:FRANge]</code> commands to determine the frequency limit value.</p> <p>OFF (0) - Turn off frequency check. The entire sweep process uses only one power sensor, not performing frequency check.</p>

Example

```
SOUR:POW:CORR:COLL:FCH ON
source1:power2:correction:collect:fcheck:state off
```

Query Syntax `SOURce:POWer:CORRection:COLLect:FCHeck[:STATe]?`

Return Type Boolean (1 = ON, 0 = OFF)

Overlapping? No

Default OFF (0)

SOURce<cnum>:POWer<port>:CORRection:COLLect:METhod <char>

(Read-Write) Select the source power calibration method. It currently only supports 'power meter'. Typically, the test software cannot ignore this order for future support other power calibration methods.

Parameter

<cnum> Any existing channel number; if unspecified, set to 1.

<port> Port number to perform source power calibration. If unspecified, set to 1.

<char> Select:
 NONE - No calibration method.
 PMETer - Power meter

Example

```
SOUR:POW:CORR:COLL:METH PMET
source1:power2:correction:collect:method pmeter
```

Query Syntax `SOURce:POWer:CORRection:COLLect:METhod?`

Return Type Char

Overlapping? No

Default NONE

SOURce<cnum>:POWER<port>:CORRection:COLLect:SAVE

(Write only) Apply the correction data after completing source power calibration sweep. Source power correction only valid for the specified source port of <cnum> channel. This command does not store the correction data.

Parameter

<cnum> Any existing channel number; if unspecified, set to 1.

<port> Port number to perform source power calibration. If unspecified, set to 1.

Example

```
SOUR:POW:CORR:COLL:SAVE
source1:power2:correction:collect:save
```

Query Syntax NONE

Overlapping? No

Default NONE

SOURce<cnum>:POWER:CORRection:COLLect:<pmChan>SENSor[:FRANge] <num1>,<num2>

(Read-Write) Specify the frequency range, where the power sensor connected to the specified channel (A and B) of power meter can be used (min and max frequency). If the power meter has only one channel, default to Channel A.

Parameter

<cnum> Any existing channel number; if unspecified, set to 1.

<pmChan> Power meter channel. Select:
A - Channel A
B - Channel B

<num1> The minimum frequency of the power sensor. If not specify the frequency unit, default to Hz. This value has no scope limitation.

<num2> The maximum frequency of the power sensor. If not specify the frequency unit, default to Hz. This value has no scope limitation.

Example

```
SOUR:POW:CORR:COLL:ASEN 100E3, 3E9
source1:power2:correction:collect:bsensor:frange 10 MHz, 18 GHz
```

Query Syntax SOURce:POWER:CORRection:COLLect:ASENSor[:FRANge]?
SOURce:POWER:CORRection:COLLect:BSENSor[:FRANge]?

Return Type Char

Overlapping? No
 Default 0,0

SOURce<num>:POWER:CORRection:COLLect:<pmChan>SENSor:RCFactor <num>

(Read-Write) Set the reference calibration factor for the power sensors connected to power meter Channel A or B. If the power meter has only one channel, default to Channel A.

Note: If the EPROM of power meter sensor connected to the specified power meter channel has calibration factor, then the other calibration factors specific to this sensor will not be used.

Parameter

<num> Any existing channel number; if unspecified, set to 1.

<pmChan> Power meter channel. Select:
 A - Channel A
 B - Channel B

<num> Reference calibration factor, expressed as a percentage. Value range: 1 to 150.

Example

```
SOUR:POW:CORR:COLL:ASEN:RCF 98.7
source1:power2:correction:collect:bsensor:rcfactor 105
```

Query Syntax SOURce:POWER:CORRection:COLLect:ASENSor:RCFactor?
 SOURce:POWER:CORRection:COLLect:BSENSor:RCFactor?

Return Type Char

Overlapping? No
 Default 100

SOURce<num>:POWER:CORRection:COLLect:TABLE:DATA <data>

(Read-Write) Read and write the selected table data. If power sensor table is selected, the data is the calibration factor expressed as a percentage; if loss difference compensation table is selected, the data is the difference in dB.

Parameter

<num> Any existing channel number; if unspecified, set to 1.

<data> Data to be written in the table.

Example

```
SOURce:POWER:CORRection:COLLect:TABLE:DATA 0.12, 0.34, 0.56
```

Query Syntax SOURce<num>:POWER:CORRection:COLLect:TABLE:DATA?

If the currently selected table is an empty table, no data is returned.

Return Type Char- a data for each table segment.

Overlapping? No

Default NONE

SOURce<cnum>:POWER:CORRection:COLLect:TABLE:FREQuency <data>

(Read-Write) Read and write frequency data from the selected table (power sensor table or loss difference compensation table).

Parameter

<cnum> Any existing channel number; if unspecified, set to 1.

<data> Frequency data to be written in the table.

Example `SOURce:POWER:CORRection:COLLect:TABLE:FREQuency 10E6, 1.5E9, 9E9`

Query Syntax `SOURce<cnum>:POWER:CORRection:COLLect:TABLE:FREQuency?`
If the currently selected table is an empty table, no data is returned.

Return Type Char - A data for each table segment.

Overlapping? No

Default NONE

SOURce<cnum>:POWER:CORRection:COLLect:TABLE:LOSS[:STATe] <ON | OFF>

(Read-Write) Set whether use the data from loss difference compensation table to correct the power meter reading during source power sweep calibration.

Parameter

<cnum> Any existing channel number; if unspecified, set to 1.

<ON|OFF> ON (or 1) - Use data from loss difference compensation table.
OFF (or 0) - Disuse data from loss difference compensation table.

Example `SOUR:POW:CORR:COLL:TABL:LOSS ON`
`source1:power2:correction:collect:table:loss:state off`

Query Syntax `SOURce:POWER:CORRection:COLLect:TABLE:LOSS[:STATe]?`

Return Type Boolean (1 = ON, 0 = OFF)

Overlapping? No
 Default OFF (0)

SOURce<cnum>:POWER:CORRection:COLLect:TABLE:POINts?

(Read only) Return the segment number of the currently selected table.

Parameter

<cnum> Any existing channel number. If unspecified, set to 1.

Example

```
SOUR:POW:CORR:COLL:TABL:POIN?
source1:power2:correction:collect:table:points?
```

Return Type Char

Overlapping? No

Default 0

SOURce<cnum>:POWER:CORRection:COLLect:TABLE[:SElect] <char>

(Read-Write) Select the data to read and write data (calibration factor table of power sensor, or loss difference compensation table). Read and write respectively using SOURce:POWER:CORRection:COLLect:TABLE:FREQUency and SOURce:POWER:CORRection:COLLect:TABLE:DATA commands.

Parameter

<cnum> Any existing channel number; if unspecified, set to 1.

Select:

NONE - None.

<char>

ASENsensor - Calibration factor table of power sensor A.

BSENsensor - Calibration factor table of power sensor B.

LOSS - Loss difference compensation table.

Example

```
SOUR:POW:CORR:COLL:TABLASEN
source1:power2:correction:collect:table:select bsensor
```

Query Syntax SOURce:POWER:CORRection:COLLect:TABLE[:SElect]?

Return Type Char

Overlapping? No

Default NONE

SOURce<num>:POWER<port>:CORRection:DATA <data>

(Read-Write) Read and write source power calibration data.

When inquire source power calibration data, if the specified channel and source port have no source power calibration data, no data is returned.

If the measurement status changes lead to source power calibration interpolation, then the returned data is also consistent with the new measurement status (including interpolation data).

Parameter

<num>	Any existing channel number; if unspecified, set to 1.
<port>	Port number of source power calibration. If unspecified, set to 1.
<data>	Correction data

Example

```
SOURce1:POWER2:CORRection:DATA 0.12, -0.34, 0.56
```

Query Syntax `SOURce<num>:POWER<port>:CORRection:DATA?`

Return Type Char - A data for each trace point.

Overlapping? No

Default NONE

SOURce<num>:POWER<port>:CORRection:LEVEl <num>

(Read-Write) Specify the power level output to the reference surface (DUT input or output).

Parameter

<num>	Any existing channel number; if unspecified, set to 1.
<port>	Port number to perform source power calibration. If unspecified, set to 1.
<num>	Calibration power level. in the unit of dBm, which may be an output of DUT, having no restriction on this value. But in fact the limitation is from the device (power sensors) used for measuring power; and the power input to the analyzer receiver, not exceeding the receiving range of analyzer receiver.

Example

```
SOUR:POW:CORR:LEV 10
source1:power2:correction:level 0dbm
```

Query Syntax `SOURce:POWER:CORRection:LEVEl?`

Return Type Char

Overlapping? No

Default 0dBm

SOURce<cnum>:POWER<port>:CORRection[:STATe] <ON|OFF>

(Read-Write) Turn on or off the source power correction function of the specified port on the specified channel.

Parameter

<cnum> Any existing channel number; if unspecified, set to 1.

<port> Port number to perform source power correction. If unspecified, set to 1.

<ON|OFF> ON (or 1) - Turn on source power correction function.
 OFF (or 0) - Turn off source power correction function.

Example

```
SOUR:POW:CORR ON
source1:power2:correction:state off
```

Query Syntax SOURce:POWER:CORRection[:STATe]?

Return Type Bool (1 = ON, 0 = OFF)

Overlapping? No

Default OFF (0)

Note: The below commands available in 1.2.0 or above.

SOURce<cnum>:POWER:PORT<port>:CORRection:COLLect[:ACQuire] <char>

(Write only) Initialize the source power calibration sweep by using the power meter sensor connected to the specified power meter channel (A or B).

Parameter

<cnum> Any existing channel number; if unspecified, set to 1.

<port> Port number to perform source power correction. If unspecified, set to 1.

<char> Select:
 ASENSor - Power sensor on power meter channel A.
 BSENSor - Power sensor on power meter channel B.

Example

```
SOUR:POW:CORR:COLL ASEN
source1:power2:correction:collect:acquire bsensor
```

Query Syntax NONE

Overlapping?	No
Default	NONE

SOURce<cnum>:POWER:PORT<port>:CORRection:COLLect:AVERage[:COUNT] <int>

(Read-Write) Turn on or off the source power correction function of the specified port on the specified channel.

Parameter

<cnum>	Any existing channel number; if unspecified, set to 1.
<port>	Port number to perform source power correction. If unspecified, set to 1.
<int>	Number of each point read, in the range: 1 to 100.

Example

```
SOUR:POW:CORR:COLL:AVER 2
source1:power2:correction:collect:average:count 3
```

Query Syntax	SOURce:POWER:CORRection:COLLect:AVERage[:COUNT]?
Return Type	Char

Overlapping?	No
Default	1

SOURce<cnum>:POWER:PORT<port>:CORRection:COLLect:TABLE:LOSS:DATA <data>

(Read-Write) Set/get the loss compensation table.

Parameter

<cnum>	Any existing channel number; if unspecified, default to 1.
<port>	Port number to perform source power correction. If unspecified, set to 1.
<data>	Data format: N,freq1,loss1,freq2,loss2... .. freqN,lossN N: number of data items set freq: frequency value (Hz) loss: loss value (dB)

Note: If the array data item is less than n when setting loss compensation table, it may lead to errors; if larger than n, it intercepts the first n items of data.

Example

```
SOUR:POW:CORR:COLL:TABL:LOSS:DATA 3,1e9,0.5,2e9,1.2,3e9,0.8
```

Query Syntax	SOURce:POWER:CORRection:COLLect:TABLE:LOSS:DATA?
--------------	--

Return Type REAL or ASCII (see Getting Data from the Analyzer)

Overlapping? No

Default NONE

SOURce<cnum>:POWER:PORT<port>:CORRection:COLLect:TABLE:LOSS[:STATE] <ON|OFF>

(Read-Write) Set whether use loss compensation table to correct the power meter reads during source power sweep calibration.

Parameter

<cnum> Any existing channel number; if unspecified, set to 1.

<port> Port number to perform source power correction. If unspecified, set to 1.

<ON|OFF> ON (or 1) - Use data from loss difference compensation table.
 OFF (or 0) - Disuse data from loss difference compensation table.

Example

```
SOUR:POW:CORR:COLL:TABL:LOSS ON
source1:power2:correction:collect:table:loss:state off
```

Query Syntax SOURce:POWER:CORRection:COLLect:TABLE:LOSS[:STATE]?

Return Type Boolean (1 = ON, 0 = OFF)

Overlapping? No

Default OFF (0)

SOURce<cnum>:POWER:PORT<port>:CORRection:DATA <data>

(Read-Write) Read and write source power calibration data.

When inquire source power calibration data, if the specified channel and source port have no source power calibration data, no data is returned.

If the measurement status changes lead to source power calibration interpolation, then the returned data is also consistent with the new measurement status (including interpolation data).

Parameter

<cnum> Any existing channel number; if unspecified, default to 1.

<port> Port number of source power calibration. If unspecified, set to 1.

<data> Correction data

Example

```
SOURce1:POWer2:CORRection:DATA 0.12, -0.34, 0.56
```

Query Syntax `SOURce<cnum>:POWer<port>:CORRection:DATA?`

Return Type Char - A data for each trace point.

Overlapping? No

Default NONE

SOURce<cnum>:POWer:PORT<port>:CORRection[:STATe] <ON|OFF>

(Read-Write) Turn on or off the source power correction function of the specified port on the specified channel.

Parameter

<cnum> Any existing channel number; if unspecified, default to 1.

<port> Port number to perform source power correction. If unspecified, set to 1.

<ON|OFF> ON (or 1) - Turn on source power correction function.
OFF (or 0) - Turn off source power correction function.

Example

```
SOUR:POW:CORR ON
source1:power2:correction:state off
```

Query Syntax `SOURce:POWer:CORRection[:STATe]?`

Return Type Bool (1 = ON, 0 = OFF)

Overlapping? No

Default OFF (0)

SOURce:POWer:PORT:CORRection:COLLect:ASENSor:RCFactor <num>

(Read-Write) Set/get the reference calibration factor (50 MHz calibration factor) of power meter A. same with `SOURce<cnum>:POWer:CORRection:COLLect:<pmChan>SENSor:RCFactor <num>`.

NOTE: If the EPROM of power meter sensor connected to the specified power meter channel has calibration factor, then the other calibration factors specific to this sensor will not be used.

Parameter

<num> Reference calibration factor, expressed as a percentage. Value range: 1 to 150.

Example

```
SOUR:POW:CORR:COLL:ASEN:RCF 98.7
source1:power2:correction:collect:asensor:rcfactor 105
```

Query Syntax SOURce:POWer:CORRection:COLLect:ASENsor:RCFactor?

Return Type Char

Overlapping? No

Default 100

Note: Only available for the current channel.

SOURce:POWer:PORT:CORRection:COLLect:BSEnSor:RCFactor <num>

(Read-Write) Set/get the reference calibration factor (50 MHz calibration factor) of power meter B. same with SOURce<cnum>:POWer:CORRection:COLLect:<pmChan>SENsor:RCFactor <num>.

NOTE: If the EPROM of power meter sensor connected to the specified power meter channel has calibration factor, then the other calibration factors specific to this sensor will not be used.

Parameter

<num> Reference calibration factor, expressed as a percentage. Value range: 1 to 150.

Example

```
SOUR:POW:CORR:COLL:BSEN:RCF 98.7
source1:power2:correction:collect:bsensor:rcfactor 105
```

Query Syntax SOURce:POWer:CORRection:COLLect:BSEnSor:RCFactor?

Return Type Char

Overlapping? No

Default 100

Note: Only available for the current channel.

SOURce<cnum>:POWer:PORT<port>:CORRection:COLLect:NTOLerance <num> (Not Achievable Temporarily)

(Read-Write) Set/get the power calibration data tolerance value of each measurement point on the specified channel and port.

Parameter

<cnum> Any existing channel number; if unspecified, default to 1.

<port> Port number to perform source power correction. If unspecified, set to 1.

<num> Power calibration tolerance value: 0 to 100 (dB)

Example

```
SOUR:POW:PORT:CORR:COLL:NTOL 20
source1:power:port2:correction:collect:ntolerance 3
```

Query Syntax	SOURce:POWer:PORT2:CORRection:COLLect:NTOLerance?
Return Type	Double (Double-precision floating-point)

Overlapping?	No
Default	5dB

SOURce:POWer:PORT:CORRection:COLLect:TABLE:ASENsor:DATA <data>

(Read-Write) Set/get the calibration factor table of power sensor A.

Parameter

Data format N ,freq1,data1,freq2,data2.....freqN,dataN

N: number of data item

<data> freq: frequency value (1kHz~500GHz)
data: calibration factor (1% to 150%)

Note: If input data item is less than N when setting, it may have errors; if greater than N, it will intercept the first N items.

Example

```
SOUR:POW:PORT:CORR:COLL:TABL:ASEN:DATA 3,1e6,98.5,1e7,99,1e8,99.5
source1:power:port2:correction:collect:table:asensor:data 2,1e9,99,2e9,98
```

Query Syntax	SOURce:POWer:PORT2:CORRection:COLLect:TABLE:ASENsor:DATA?
Return Type	REAL or ASCii (see Getting Data from the Analyzer)

Overlapping?	No
Default	NONE

SOURce:POWer:PORT:CORRection:COLLect:TABLE:BSENsor:DATA <data>

(Read-Write) Set/get the calibration factor table of power sensor B.

Parameter

Data format N ,freq1,data1,freq2,data2.....freqN,dataN

N: number of data item

<data> freq: frequency value (1kHz~500GHz)
data: calibration factor (1% to 150%)

Note: If input data item is less than N when setting, it may have errors; if greater than N, it will intercept the first N items.

Example

```
SOUR:POW:PORT:CORR:COLL:TABL:BSEN:DATA 3,1e6,98.5,1e7,99,1e8,99.5
source1:power:port2:correction:collect:table:bsensor:data 1,10200000,98
```

Query Syntax SOURce:POWER:PORT2:CORRection:COLLect:TABLE:BSensor:DATA?
 Return Type REAL or ASCii (see Getting Data from the Analyzer)

Overlapping? No
 Default NONE

Status Register Commands

It can inquire the status of event selected by analyzer by using status register.

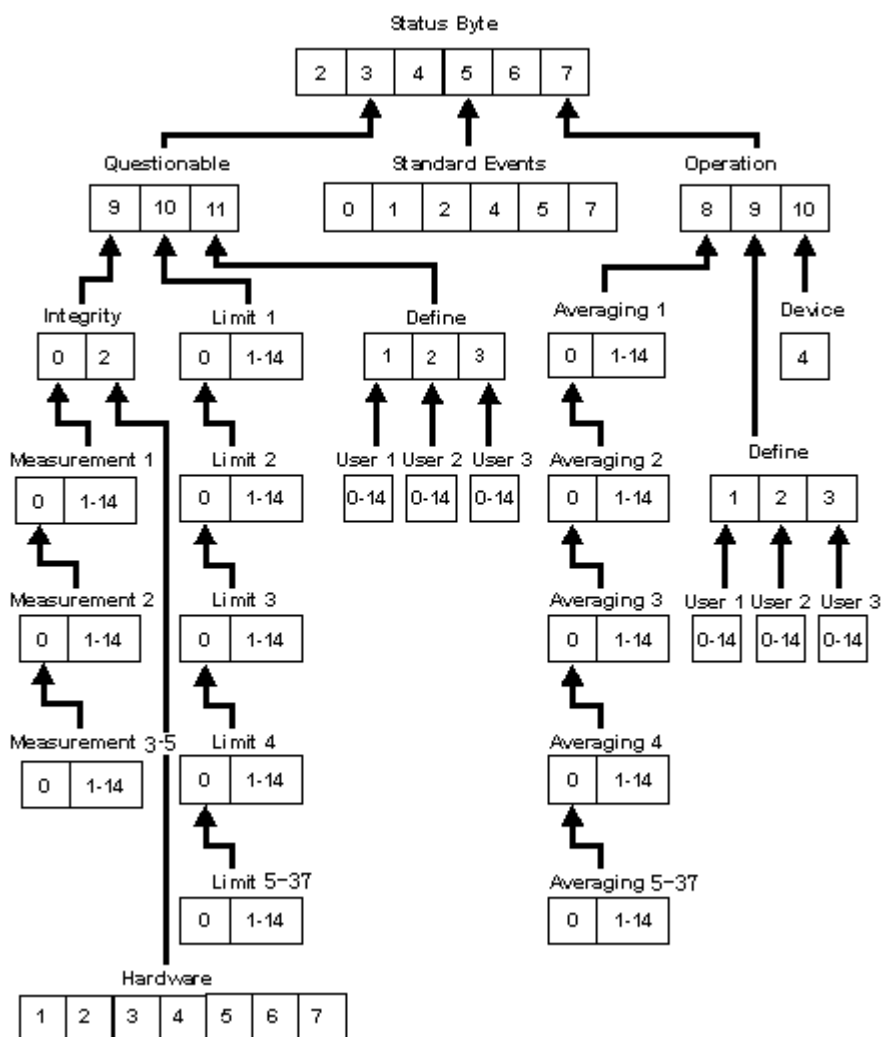

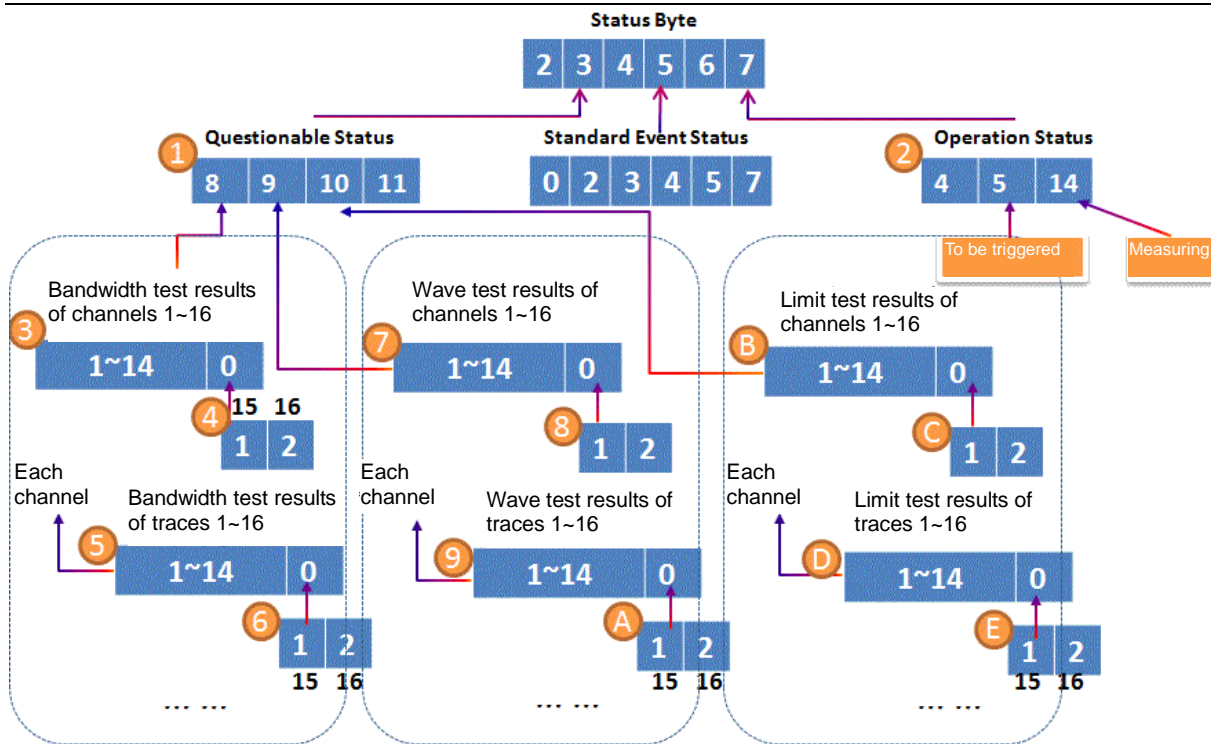

Note: This file requires the user to be familiar with the “Standard Status Data Structure - Memory Model” section in IEEE Std 488.2-1992.

Note: The bits not identified in the register are the reserved ones not used for yet.

Status Command Keyword

The following keyword can be added to the back of the register node to be controlled.

- :CONDition?
- :ENABle
- :ENABle?
- :EVENT?
- :MAP
- :NTRansition
- :PTRansition

:CONDition?

Real-time monitoring mode. But it also means a certain status has been produced, but might be cleared away before reading. Read this register, it returns a weighted value in 16 decimal.

:ENABle <bit>

Use a service request (SRQ) method to monitor Enable register bits. (it will not enable this bit when using directing reading method).

STATus:QUESTionable:ENABle and STATus:OPERation:ENABle is default to 0: no enable bit.

All other register_is: ENABle <bits> is 32767: all enabled.

So it wants to ban certain status bits, just send ENABLE keyword. For example: only enable the Trace 1 bit (2nd bit) of LIMIT1 register, the other bit is disabled, then send the command: STATUS:QUESTIONable:LIMit1:ENABle 2

:ENABle?

Read the Enable register to determine the enabled bits. Return a 16-bit enabled weighted sum.

[:EVENT]?

Only for query - Default keyword of most registers. It can be used to view whether a status has occurred or not. These bits keep the set value before reading or clearing.

:MAP <bit>,<error>

Association a bit of User register to an error bit. Such as:

STATUS:QUESTIONable:DEFine:USER2:MAP 0,1400

0 is bit to be set.

1400 is error bit.

When error 1400 "syntax error" occurs, 0-bit of USER2 is set to 1.

:NTRansition <bits>

Write-read backward transition register, used to set the transition from True to False. Use this register if only interested in the transition from True to False.

:NTRansition?

Inquire the register, to view whether backward transition occurs.

:PTRansition <bits>

Write-read forward transition register, used to set the transition from False to True. Use this register if only interested in the transition from False to True.

:PTRansition?

Inquire the register, to view whether forward transition occurs.

Status Byte Register

Summarize the status of other registers and monitor the output queue of the analyzer, and at the same time generate a service request. Enable register is also known as Service Request Enable register.

Command	Description
*CLS	Clear all 'Event register and SCPI error/event queue. But the corresponding Enable register will not be affected.
*STB?	Read the value of analyzer status byte. The byte value remains unchanged after reading.
*SRE?	Read the current status of Service Request Enable Register.
*SRE <num>	Set the bit value of Service Request Enable Register. The current setting of SRE register is stored to the non-volatile memory. Use *SRE 0 command to clear enable. <num> is the weighted sum of the bit set.

Bit	Weight	Description	Set the corresponding bits to 1 under the following conditions:
2	4	Error/event queue summary (EAV)	Set bit when error/event queue is not empty. Use SYST:ERR? command to read error message.
3	8	Questionable register summary	Set bit when any enable bit of questionable event register is 1.
4	16	Message occurrence	Set bit when output queue is not empty.
5	32	Standard Event register summary	Set bit when any enable bit of standard event register is 1.
6	64	Request service	Set bit to 1 when any other bit of status register is 1 (used to warn the controller of service request). It cannot ban this bit.
7	128	Operation register summary	Set bit to 1 when any enable bit of operation event register is 1.

STATus:QUEStionable:<keyword>

Summarize the measurement data status.

<keyword>	Example
:CONDition?	STAT:QUES:COND?
:ENABle <bits>	STAT:QUES:ENAB 1024
[:EVENT]?	STAT:QUES?
:NTRansition <bits>	STAT:QUES:NTR 1024
:PTRansition <bits>	STAT:QUES:PTR 0

Bit	Weight	Description	Set the corresponding bits to 1 under the following conditions:
9	512	Integrity register summary	Set bit to 1 when any enable bit of Integrity event register is 1.
10	1024	Limit register summary	Set bit to 1 when any enable bit of Limit event register is 1.
11	2048	Define register summary	Set bit to 1 when any enable bit of Define event register is 1.

STATus:QUEStionable:INTegrity <keyword>

Summarize the status of Integrity register.

<keyword>	Example
:CONDition?	STAT:QUES:INT:COND?
:ENABle <bits>	STAT:QUES:INT:ENAB 1024
[:EVENT]?	STAT:QUES:INT?
:NTRansition <bits>	STAT:QUES:INT:NTR 1024
:PTRansition <bits>	STAT:QUES:INT:PTR 0

Bit	Weight	Description	Set the corresponding bits to 1 under the following conditions:
0	1	Measurement summary	Set bit to 1 when any enable bit of Integrity event register is 1.
2	2	Hardware status summary	Set bit to 1 when any enable bit of Hardware event register is 1.

STATus:QUEStionable:INTEgrity:HARDware<keyword>

Monitor the hardware failure.

<keyword>	Example
:CONDition?	STAT:QUES:INT:HARD:COND?
:ENABle <bits>	STAT:QUES:INT:HARD:ENAB 1024
[[:EVENT]?	STAT:QUES:INT:HARD?
:NTRansition <bits>	STAT:QUES:INT:HARD:NTR 1024
:PTRansition <bits>	STAT:QUES:INT:HARD:PTR 0

Bit	Weight	Description	Set the corresponding bits to 1 under the following conditions:
1	2	Phase unlock	Source losing lock. It may be caused by reference channel is on or hardware failure.
2	4	Unleveled	Source power is unleveled. It may be caused by power set is too excessive to exceed the adjustable range of hardware, or hardware failure.
3	8	Overload	The input power is too excessive. It may be caused by amplifier or hardware failure.
4	16	EEPROM write failure.	Fail to write to EEPROM. It may be caused by hardware failure.
5	32	YIG calibration failure	YIG cannot perform calibration. It may be caused by losing lock or hardware failure.
6	64	Slope calibration failure	The analog slope calibration failure may be caused by hardware failure.
7	128	Excessive temperature	It may be caused by bad ventilation or fan failure.

STATus:QUEStionable:INTEgrity:MEASurement<n> <keyword>

Monitor the time difference between changing channel setting and preparing data for inquire the output. When the channel status (start/stop frequency, bandwidth, etc.) changes, questionable bits associated with that channel will be set bit. The channel trace data inquired at this time is the data before changing channel status, that is the data does not match the current setting status of channel. The the next sweep is completed (without stop), the data matches the channel status, then the corresponding bit of questionable will be cleared.

<n> Number of measurement registers, with value range of 1 to 5.

<keyword>	Example
:CONDition?	STAT:QUES:INT:MEAS1:COND?
:ENABle <bits>	STAT:QUES:INT:MEAS2:ENAB 1024
[:EVENT]?	STAT:QUES:INT:MEAS3?
:NTRansition <bits>	STAT:QUES:INT:MEAS2:NTR 1024
:PTRansition <bits>	STAT:QUES:INT:MEAS1:PTR 0

		Measurement Register <n>					
Bit	Weight	1	2	3	4	5	Set the corresponding bits to 1 under the following conditions:
0	1	2, 3, 4, 5	3, 4, 5	4, 5	5		Summary - Settings of any channel corresponded with register have been changed, but the data has not been refreshed.
		Channel Number					
1	2	1	15	29	43	57	Channel setting has been changed, but the data has not been refreshed.
2	4	2	16	30	44	58	Channel setting has been changed, but the data has not been refreshed.
3	8	3	17	31	45	59	Channel setting has been changed, but the data has not been refreshed.
4	16	4	18	32	46	60	Channel setting has been changed, but the data has not been refreshed.
5	32	6	19	32	47	61	Channel setting has been changed, but the data has not been refreshed.
6	64	6	20	34	48	62	Channel setting has been changed, but the data has not been refreshed.
7	128	7	21	35	49	63	Channel setting has been changed, but the data has not been refreshed.
8	256	8	22	36	50	64	Channel setting has been changed, but the data has not been refreshed.
9	512	9	23	37	51		Channel setting has been changed, but the data has not been refreshed.
10	1024	10	24	38	52		Channel setting has been changed, but the data has not been refreshed.
11	2048	11	25	39	53		Channel setting has been changed, but the data has not been refreshed.
12	4096	12	26	40	54		Channel setting has been changed, but the data has not been refreshed.
13	8192	13	27	41	55		Channel setting has been changed, but the data has not been refreshed.

14	16384	14	28	42	56	Channel setting has been changed, but the data has not been refreshed.
----	-------	----	----	----	----	--

STATus:QUEStionable:LIMit<n> <keyword>

Monitor and summarize the limit line failure status. When the limit test of a trace fails, the corresponding bit is set to 1. 0-bit of each register is used to summarize the status of other registers after this one. For example: 0-bit of Limit3 register summarizes the failure status from register 4, 537.

All enable bit is set to 1 when default.

<n>	Limit Register number. Value range: 1 – 37.
<keyword>	Example
:CONDition?	STAT:QUES:LIM4:COND?
:ENABle <bits>	STAT:QUES:LIM1:ENAB 1024
[:EVENT]?	STAT:QUES:LIM3?
:NTRansition <bits>	STAT:QUES:LIM2:NTR 1024
:NTRansition?	STAT:QUES:LIM1:NTR?
:PTRansition <bits>	STAT:QUES:LIM5:PTR 0
:PTRansition?	STAT:QUES:LIM1:PTR?

		Limit Register <n>						
Bit	Weight	1	2	3	... 37		Set the corresponding bits to 1 under the following conditions:	
0	1	2, 3, ...,37	3, 4, ...,37	4, 5 ...,37	... 37		Summarize - Any failure point performed on these registers.	
		Trace Number						
1	2	1	15	29	... 505		Any failure point of limit test.	
2	4	2	16	30	... 506		Any failure point of limit test.	
3	8	3	17	31	... 507		Any failure point of limit test.	
4	16	4	18	32	... 508		Any failure point of limit test.	
5	32	5	19	33	... 509		Any failure point of limit test.	
6	64	6	20	34	... 510		Any failure point of limit test.	
7	128	7	21	35	... 511		Any failure point of limit test.	
8	256	8	22	36	... 512		Any failure point of limit test.	
9	512	9	23	37	...		Any failure point of limit test.	
10	1024	10	24	38	...		Any failure point of limit test.	
11	2048	11	25	39	...		Any failure point of limit test.	

12	4096	12	26	40	...	Any failure point of limit test.
13	8192	13	27	41	...	Any failure point of limit test.
14	16384	14	28	42	...	Any failure point of limit test.

Note: The registers used above are not fully lists due to excessive quantity. The unlisted part shares the same function with the listed part.

STATus:QUEStionable:DEFine<keyword>

Summarize the status of Questionable:Define:User<1|2|3> event register.

<keyword>	Example
:CONDition?	STAT:QUES:DEF:COND?
:ENABle <bits>	STAT:QUES:DEF:ENAB 1024
[:EVENT]?	STAT:QUES:DEF?
:NTRansition <bits>	STAT:QUES:DEF:NTR 1024
:PTRansition <bits>	STAT:QUES:DEF:PTR 0

Bit	Weight	Description	Set the corresponding bits to 1 under the following conditions:
1	2	USER1	When any bit of USER1 event register is 1.
2	4	USER2	When any bit of USER2 event register is 1.
3	8	USER3	When any bit of USER3 event register is 1.

STATus:QUEStionable:DEFine:USER<1|2|3><keyword>

Monitor the user definition and the event status mapping in one of QUES:DEF:USER registers.

<keyword>	Example
:ENABle <bits>	STAT:QUES:DEF:USER1:ENABle 1024
[:EVENT]?	STAT:QUES:DEF:USER1?
:MAP <bit>,<error>	STAT:QUES:DEF:USER1:MAP 0,1400 'when 1400 error occurs, 0-bit of USER1 is set to 1.

Bit	Weight	Description	Set the corresponding bits to 1 under the following conditions:
0	1	Reserved for user	User definition
1	2	Reserved for user	User definition
2	4	Reserved for user	User definition
3	8	Reserved for user	User definition

4	16	Reserved for user	User definition
5	32	Reserved for user	User definition
6	64	Reserved for user	User definition
7	128	Reserved for user	User definition
8	256	Reserved for user	User definition
9	512	Reserved for user	User definition
10	1024	Reserved for user	User definition
11	2048	Reserved for user	User definition
12	4096	Reserved for user	User definition
13	8192	Reserved for user	User definition
14	16384	Reserved for user	User definition

Standard Event Status Register

Monitor "standard" event generated by analyzer. This register can only be cleared by the following method:

Clear commands (*CLS).

Read Standard enable status register (*ESE?).

Startup. Analyzer records all transition status after clearing registers, including setting the 7th bit (startup bit).

Command Description

*ESE? Read the setting value of "standard" event ENABLE register.

*ESE
<bits> Set the value of "standard" event ENABLE register. The current settings are stored in non-volatile memory.
<bits> is the weighted sum of registers. Use *ESE 0 command to clear the enable register.

*ESR? Read and clear the EVENT setting of "standard" event status register.

*OPC Bit-0 is set to 1 when completing overlapping commands.

*OPC? Inquire operation completion status – read the operation complete bit (bit 0).

Bit	Weight	Description	Set the corresponding bits to 1 under the following conditions:
0	1	Operation completed	Occur the following two events in sequence: Send *OPC command to analyzer. Analyzer completes performing all overlapping commands.
1	NA	Reserve	Reserve
2	4	Inquire error	That query Error is detected means: - Read data when the output queue has no data. Or

			- Data in output queue is lost, such as overflow.
4	16	Perform error	That perform error is detected means: - Data breaks bound or data does not match the current analyzer operation. Or - It cannot perform the valid commands owing to some analyzer status.
5	32	Command error	Command error means analyzer has received the following commands: Having syntax error. Having spelling error. Which is an inexecutable option command.
7	128	Startup	The analyzer has performed startup or shutdown for one time after the last time reads this register.

STATus:OPERation<keyword>

Summarize the status of Averaging and Operation:Define:User<1|2|3> event registers.

<keyword>	Example
:CONDition?	STAT:OPER:COND?
:ENABle <bits>	STAT:OPER:ENAB 1024
[:EVENT]?	STAT:OPER?
:NTRansition <bits>	STAT:OPER:NTR 1024
:PTRansition <bits>	STAT:OPER:PTR 0

Bit	Weight	Description	Set the corresponding bits to 1 under the following conditions:
8	256	Averaging summary	When any bit of Averaging register is set to 1, this bit is set to 1.
9	512	User self-definition summary	
10	1024	Device summary	When any bit of Device register is set to 1, this bit is set to 1.

STATus:OPERation:AVERaging<n> <keyword>

Monitor and summarize the averaging operation status of Trace 1 to 512. When the averaging of a trace is completed, the corresponding bit is set to 1. 0-bit of each register is used to summarize the status of other registers after this one. For example: 0-bit of Average 3 register summarizes the status of register 4, 5.....37. All enable bit is default to 1. Use Calc:Par:Mnum to inquire the measurement number.

<n>	Averaging Register number Value range: 1 - 37
<keyword>	Example
:CONDition?	STAT:OPER:AVER1:COND?
:ENABle <bits>	STAT:OPER:AVER1:ENAB 1024
[:EVENT]?	STAT:OPER:AVER1?

:NTRansition <bits> STAT:OPER:AVER1:NTR 1024
 :PTRansition <bits> STAT:OPER:AVER1:PTR 0

		Averaging Register <n>					
Bit	Weight	1	2	3	...	37	Set the corresponding bits to 1 under the following conditions:
0	1	2, 3, ...,37	3, 4, ...,37	4, 5, ...,37	...		When any bit of these registers is set to 1, this bit is set to 1 (summary bit).
		Trace Number					
1	2	1	15	29	...	505	Set bit after completing averaging operation
2	4	2	16	30	...	506	Set bit after completing averaging operation
3	8	3	17	31	...	507	Set bit after completing averaging operation
4	16	4	18	32	...	508	Set bit after completing averaging operation
5	32	5	19	33	...	509	Set bit after completing averaging operation
6	64	6	20	34	...	510	Set bit after completing averaging operation
7	128	7	21	35	...	511	Set bit after completing averaging operation
8	256	8	22	36	...	512	Set bit after completing averaging operation
9	512	9	23	37	...		Set bit after completing averaging operation
10	1024	10	24	38	...		Set bit after completing averaging operation
11	2048	11	25	39	...		Set bit after completing averaging operation
12	4096	12	26	40	...		Set bit after completing averaging operation
13	8192	13	27	41	...		Set bit after completing averaging operation
14	16384	14	28	42	...		Set bit after completing averaging operation

Note: The registers used above are not fully lists due to excessive quantity. The unlisted part shares the same function with the listed part.

STATus:OPERation:DEFine<keyword>

Summarize the status of OPERation:Define:User<1|2|3> event register.

<keyword>	Example
:CONDition?	STAT:OPER:DEF:COND?
:ENABle <bits>	STAT:OPER:DEF:ENAB 12
[:EVENTt]?	STAT:OPER:DEF?
:NTRansition <bits>	STAT:OPER:DEF:NTR 12
:PTRansition <bits>	STAT:OPER:DEF:PTR 0

Bit	Weight	Description	Set the corresponding bits to 1 under the following conditions:
1	2	USER1	USER1 If any bit in the register is set to 1, then this bit is set to 1.
2	4	USER2	USER2 If any bit in the register is set to 1, then this bit is set to 1.
3	8	USER3	USER3 If any bit in the register is set to 1, then this bit is set to 1.

STATus:OPERation:DEFine:USER<1|2|3><keyword>

Monitor the user definition and the event status mapping in one of OPER:DEF:USER registers.

<keyword> Example

:ENABLE <bits> STAT:OPER:DEF:USER1:ENAB 1024

[:EVENT]? STAT:OPER:DEF:USER1?

:MAP <bit>,<error> STAT:OPER:DEF:USER1:MAP 0,1400 'when 1400 error occurs, 0-bit of USER1 is set to 1.

Bit	Weight	Description	Set the corresponding bits to 1 under the following conditions:
0	1	Reserved for user	Set bit upon user definition
1	2	Reserved for user	Set bit upon user definition
2	4	Reserved for user	Set bit upon user definition
3	8	Reserved for user	Set bit upon user definition
4	16	Reserved for user	Set bit upon user definition
5	32	Reserved for user	Set bit upon user definition
6	64	Reserved for user	Set bit upon user definition
7	128	Reserved for user	Set bit upon user definition
8	256	Reserved for user	Set bit upon user definition
9	512	Reserved for user	Set bit upon user definition
10	1024	Reserved for user	Set bit upon user definition
11	2048	Reserved for user	Set bit upon user definition
12	4096	Reserved for user	Set bit upon user definition
13	8192	Reserved for user	Set bit upon user definition
14	16384	Reserved for user	Set bit upon user definition

STATus:OPERation:DEvice<keyword>

Summarize the status of OPERation:DEvice event register.

<keyword>	Example
:CONDition?	STAT:OPER:DEV:COND?
:ENABle <bits>	STAT:OPER:DEV:ENAB 16
[:EVENT]?	STAT:OPER:DEV?
:NTRansition <bits>	STAT:OPER:DEV:NTR 16
:PTRansition <bits>	STAT:OPER:DEV:PTR 0

Bit	Weight	Description	Set the corresponding bits to 1 under the following conditions:
0	1	Unused	
1	2	Unused	
2	4	Unused	
3	8	Unused	
4	16	Sweep completed	Set bit after completing sweep
5	32	Unused	
6	64	Unused	
7	128	Unused	
8	256	Unused	
9	512	Unused	
10	1024	Unused	
11	2048	Unused	
12	4096	Unused	
13	8192	Unused	
14	16384	Unused	

STATus:OPERation:CONDition

(Read-Write) Read the value of the operation status condition register.

Parameter

<value> Long - Value of the operation status condition register.

Example STATus:OPERation:CONDition?

Query Syntax STATus:OPERation:CONDition?

Overlapping? No

Default NONE

STATus:OPERation:ENABLE

(Read only) Set/get the value of the operation status startup register.

Parameter

<value> Long - Value of the operation status startup register. 0 to 65535, bit 0 to bit 3. Bit 6 to bit 13 and bit 15 cannot be set to 1.

Example `STATus:OPERation:ENABLE 16`

Query Syntax `STATus:OPERation:ENABLE?`

Overlapping? No

Default 0

STATus:OPERation:EVENT

(Read only) Read the value of the operation status event register.

Parameter

<value> Long - Value of the operation status event register.

Example `STATus:OPERation:EVENT?`

Query Syntax `STATus:OPERation:EVENT?`

Overlapping? No

Default NONE

STATus:OPERation:NTRansition

(Read only) Set/get the value of the negative transition filter of the operation status register.

Parameter

<value> Long - Value of the negative transition filter. 0 to 65535, bit 0 to bit 3. Bit 6 to bit 13 and bit 15 cannot be set to 1.

Example **STATus:OPERation:NTRansition 16**

Query Syntax **STATus:OPERation:NTRansition?**

Overlapping? No

Default 0

STATus:OPERation:PTRansition

(Read-Write) Set/get the value of the positive transition filter of the operation status register.

Parameter

<value> Long- Value of the positive transition filter. 0 to 65535, bit 0 to bit 3. Bit 6 to bit 13 and bit 15 cannot be set to 1.

Example **STATus:OPERation:PTRansition?**

Query Syntax **STATus:OPERation:PTRansition?**

Overlapping? No

Default 16432

STATus:PRESet

(Write only) Initialization

Parameter NONE

Query Syntax **SCPI:STATus:PRESet**

Overlapping? No

Default NONE

STATus:QUESTionable:BLIMit:CHANnel<cnum>:CONDition

(Read only) Read the value of the questionable bandwidth limit channel status condition register of specified channel.

Parameter

<cnum> Long - Number of channels.

<value> Long - Value of the questionable bandwidth limit channel status condition register.

Example `STATus:QUEStionable:BLIMit:CHANnel:CONDition?`

Query Syntax `STATUS:QUEStionable:BLIMit:CHANnel<cnum>:CONDition?`

Overlapping? No

Default 1

STATus:QUEStionable:BLIMit:CHANnel<cnum>:ECHannel:CONDition

(Read-Write) Read the value of the limited channel status condition register with questionable bandwidth of specified channel.

Parameter

<cnum> Long - Number of channels.

<value> Long - Value of the questionable bandwidth limit channel additional event register.

Example `STATus:QUEStionable:BLIMit:CHANnel:ECHannel:CONDition?`

Query Syntax `STATUS:QUEStionable:BLIMit:CHANnel<cnum>:ECHannel:CONDition?`

Overlapping? No

Default 1

STATus:QUEStionable:BLIMit:CHANnel<cnum>:ECHannel:ENABLE

(Read only) Set/get the value of the questionable bandwidth limit channel additional status enabling register of specified channel.

Parameter

<cnum> Long - Number of channels.

<value> Long - Value of the enabling register. 0 to 65535, bit 0, bit 3 to bit 15 cannot be set to 1.

Example `STATus:QUEStionable:BLIMit:CHANnel:ECHannel:ENABLE 6`

Query Syntax `STATUS:QUEStionable:BLIMit:CHANnel<cnum>:ECHannel:ENABLE?`

Overlapping? No

Default 1

STATus:QUEStionable:BLIMit:CHANnel<cnum>:ECHannel:EVENT

(Read only) Read the value of the “questionable bandwidth limit channel additional status event register” of specified channel.

Parameter

<cnum> Long - Number of channels.

<value> Long - Value of the questionable bandwidth limit channel additional event register.

Example `STATus:QUEStionable:BLIMit:CHANnel:ECHannel:EVENT 6`

Query Syntax `STATUS:QUEStionable:BLIMit:CHANnel<cnum>:ECHannel:EVENT?`

Overlapping? No

Default 1

STATus:QUEStionable:BLIMit:CHANnel<cnum>:ECHannel:NTRansition

(Read-Write) Set/get the value of the negative transition filter of the “questionable bandwidth limit channel additional status register” of specified channel.

Parameter

<cnum> Long - Number of channels.

<value> Long - Value of the negative transition filter of the “questionable bandwidth limit channel additional status register” of specified channel. 0 to 65535, bit 0, bit 3 to bit 15 cannot be set to 1, default to 0.

Example `STATus:QUEStionable:BLIMit:CHANnel:ECHannel:NTRansition 6`

Query Syntax `STATUS:QUEStionable:BLIMit:CHANnel<cnum>:ECHannel:NTRansition?`

Overlapping? No

Default 1

STATus:QUEStionable:BLIMit:CHANnel<cnum>:ECHannel:PTRansition

(Read-Write) Set/get the value of the positive transition filter of the “questionable bandwidth limit channel additional status register” of specified channel.

Parameter

<cnum>	Long - Number of channels.
<value>	Long - Value of the positive transition filter of the “questionable bandwidth limit channel additional status register” of specified channel. 0 to 65535, bit 0, bit 3 to bit 15 cannot be set to 1.

Example `STATUS:QUESTIONable:BLIMit:CHANnel:EChannel:PTRansition 16`

Query Syntax `STATUS:QUESTIONable:BLIMit:CHANnel<cnum>:EChannel:PTRansition?`

Overlapping? No

Default 1

STATUS:QUESTIONable:BLIMit:CHANnel<cnum>:ENABLE

(Read-Write) Set/get the value of the “questionable bandwidth limit channel status enabling register” of specified channel.

Parameter

<cnum>	Long - Number of channels.
<value>	Long - Value of the questionable bandwidth limit channel status enabling register. 0 to 65535, bit 15 cannot be set to 1.

Example `STATUS:QUESTIONable:BLIMit:CHANnel:ENABLE 16`

Query Syntax `STATUS:QUESTIONable:BLIMit:CHANnel<cnum>:ENABLE?`

Overlapping? No

Default 1

STATUS:QUESTIONable:BLIMit:CHANnel<cnum>:EVENT

(Read only) Read the value of the “questionable bandwidth limit channel status event register” of specified channel.

Parameter

<cnum>	Long - Number of channels.
<value>	Long - Value of the questionable bandwidth limit channel status event register.

Example `STATUS:QUESTIONable:BLIMit:CHANnel:EVENT?`

Query Syntax **STATUS:QUEStionable:BLIMit:CHANnel<cnum>:EVENT?**

Overlapping? No

Default 1

STATus:QUEStionable:BLIMit:CHANnel<cnum>:NTRansition

(Read-Write) Set/get the value of the positive transition filter of the “questionable bandwidth limit channel status register” of specified channel.

Parameter

<cnum> Long - Number of channels.

<value> Long - Value of the negative transition filter of the “questionable bandwidth limit channel status register” of specified channel. 0 to 65535, default to 0.

Example **STATus:QUEStionable:BLIMit:CHANnel2:NTRansition 16**

Query Syntax **STATUS:QUEStionable:BLIMit:CHANnel<cnum>:NTRansition?**

Overlapping? No

Default 1

STATus:QUEStionable:BLIMit:CHANnel<cnum>:PTRansition

(Read-Write) Set/get the value of the positive transition filter of the “limited channel status register with questionable bandwidth” of specified channel.

Parameter

<cnum> Long - Number of channels.

<value> Long - Value of the positive transition filter of the questionable bandwidth limit channel status register. 0 to 65535, bit 15 cannot be set to 1.

Example **STATus:QUEStionable:BLIMit:CHANnel2:PTRansition 16**

Query Syntax **STATUS:QUEStionable:BLIMit:CHANnel<cnum>:PTRansition?**

Overlapping? No

Default 1

STATus:QUEStionable:BLIMit:CONDition

(Read only) Read the value of the questionable bandwidth additional status condition register.

Parameter

<value> Long - Value of the questionable bandwidth additional status condition register.

Example `STATus:QUEStionable:BLIMit:CONDition ?`

Query Syntax `STATUS:QUEStionable:BLIMit:CONDition?`

Overlapping? No

Default NONE

STATus:QUEStionable:BLIMit:ELIMit:CONDition

(Read-Write) Read the value of the questionable bandwidth limit additional status condition register.

Parameter

<value> Long - Value of the questionable bandwidth additional status condition register.

Example `STATus:QUEStionable:BLIMit:ELIMit:CONDition 16`

Query Syntax `STATUS:QUEStionable:BLIMit:ELIMit:CONDition?`

Overlapping? No

Default NONE

STATus:QUEStionable:BLIMit:ELIMit:ENABLE

(Read-Write) Set/get the value of the questionable bandwidth limit additional status enabling register.

Parameter

<value> Long - Value of the questionable bandwidth limit additional status enabling register. 0 to 65535, bit 0, bit 3 to bit 15 cannot be set to 1.

Example `STATus:QUEStionable:BLIMit:ELIMit:ENABLE 6`

Query Syntax `STATUS:QUEStionable:BLIMit:ELIMit:ENABLE?`

Overlapping? No

Default NONE

STATus:QUEStionable:BLIMit:ELIMit:EVENT

(Read only) Read the value of the questionable bandwidth additional status event register.

Parameter

<value> Long - Value of the questionable bandwidth limit additional event register.

Example `STATus:QUEStionable:BLIMit:ELIMit:EVENT?`

Query Syntax `STATUS:QUEStionable:BLIMit:ELIMit:EVENT?`

Overlapping? No

Default NONE

STATus:QUEStionable:BLIMit:ELIMit:NTRansition

(Read-Write) Set/get the value of the negative transition filter of the questionable bandwidth limit additional status register.

Parameter

<value> Long - Value of the negative transition filter of the questionable bandwidth limit additional status register. 0 to 65535, bit 0, bit 3 to bit 15 cannot be set to 1.

Example `STATus:QUEStionable:BLIMit:ELIMit:NTRansition 6`

Query Syntax `STATUS:QUEStionable:BLIMit:ELIMit:NTRansition?`

Overlapping? No

Default 0

STATus:QUEStionable:BLIMit:ELIMit:PTRansition

(Read-Write) Set/get the value of the positive transition filter of the questionable bandwidth limit additional status register.

Parameter

<value> Long - Value of the positive transmission filter of the questionable bandwidth limit additional status register. 0 to 65535, bit 0, bit 3 to bit 15 cannot be set to 1.

Example `STATus:QUEStionable:BLIMit:ELIMit:PTRansition 6`

Query Syntax `STATUS:QUEStionable:BLIMit:ELIMit:PTRansition?`

Overlapping? No

Default NONE

STATus:QUEStionable:BLIMit:ENABLE

(Read-Write) Set/get the value of the questionable bandwidth limit status enabling register.

Parameter

<value> Long - Value of the questionable bandwidth limit status enabling register. 0 to 65535, bit 15 cannot be set to 1.

Example `STATus:QUEStionable:BLIMit:ENABLE 6`

Query Syntax `sSTATUS:QUEStionable:BLIMit:ENABLE?`

Overlapping? No

Default NONE

STATus:QUEStionable:BLIMit:EVENT

(Read only) Read the value of the questionable bandwidth limit status event register.

Parameter

<value> Long - Value of the questionable bandwidth limit status event register.

Example `STATus:QUEStionable:BLIMit:EVENT?`

Query Syntax `STATUS:QUEStionable:BLIMit:EVENT?`

Overlapping? No

Default NONE

STATus:QUEStionable:BLIMit:NTRansition

(Read-Write) Set/get the value of the negative transition filter of the questionable bandwidth limit status register.

Parameter

<value> Long - Value of the negative transition filter of the questionable bandwidth limit status register. 0 to 65535, bit 0, bit 3 to bit 15 cannot be set to 1.

Example `STATus:QUEStionable:BLIMit:NTRansition 16`

Query Syntax `STATUS:QUEStionable:BLIMit:NTRansition?`

Overlapping? No

Default 0

STATus:QUEStionable:BLIMit:PTRansition

(Read-Write) Set/get the value of the positive transition filter of the questionable bandwidth limit status register.

Parameter

<value> Long - Value of the positive transition filter of the questionable bandwidth limit status register. 0 to 65535, bit 15 cannot be set to 1.

Example `STATus:QUEStionable:BLIMit:PTRansition 16`

Query Syntax `STATUS:QUEStionable:BLIMit:PTRansition?`

Overlapping? No

Default NONE

STATus:QUEStionable:CONDition

(Read only) Read the value of the questionable status condition register.

Parameter

<value> Long - Value of the questionable status event register.

Example `STATus:QUEStionable:CONDition?`

Query Syntax `STATUS:QUEStionable:CONDition?`

Overlapping? No

Default NONE

STATus:QUEStionable:ENABle

(Read-Write) Set/get the value of the questionable status enabling register.

Parameter

<value> Long - Value of the questionable status enabling register. 0 to 65535, bit 0 to bit 9. Bit 11 to bit 13 and bit 11 to bit 15 cannot be set to 1.

Example `STATus:QUEStionable:ENABle 16`

Query Syntax `STATUS:QUEStionable:ENABle?`

Overlapping? No

Default 0

STATus:QUEStionable:EVENT

(Read only) Read the value of the questionable status event register.

Parameter

<value> Long - Value of the questionable status event register.

Example `STATus:QUEStionable:EVENT?`

Query Syntax `STATUS:QUEStionable:EVENT?`

Overlapping? No

Default NONE

STATus:QUEStionable:LIMit:CHANnel<cnum>:CONDition

(Read only) Read the value of the questionable limit channel status condition register of specified channel.

Parameter

<cnum> Long - Number of channels.

<value> Long - Value of the questionable limit channel status condition register.

Example **STATus:QUEStionable:LIMit:CHANnel:CONDition?**

Query Syntax **STATUS:QUEStionable:LIMit:CHANnel<cnum>:CONDition?**

Overlapping? No

Default 1

STATus:QUEStionable:LIMit:CHANnel<cnum>:ECHANnel:CONDition

(Read-Write) Read the value of the questionable limit channel status condition register of specified channel.

Parameter

<cnum> Long - Number of channels.

<value> Long - Value of the questionable limit channel additional status event register.

Example **STATus:QUEStionable:LIMit:CHANnel:ECHANnel:NDition?**

Query Syntax **STATUS:QUEStionable:LIMit:CHANnel<cnum>:ECHANnel:CONDition?**

Overlapping? No

Default 1

STATus:QUEStionable:LIMit:CHANnel<cnum>:ECHANnel:ENABLE

(Read only) Set/get the value of the questionable limit channel additional status enabling register of specified channel.

Parameter

<cnum> Long - Number of channels.

<value> Long - Value of the enabling register. 0 to 65535, bit 0, bit 3 to bit 15 cannot be set to 1.

Example **STATus:QUEStionable:LIMit:CHANnel2:ECHANnel:ENABLE 6**

Query Syntax **STATUS:QUEStionable:LIMit:CHANnel<cnum>:ECHANnel:ENABLE?**

Overlapping? No

Default 1

STATus:QUEStionable:LIMit:CHANnel<num>:EChannel:EVENT

(Read only) Read the value of the “questionable limit channel additional status event register” of specified channel.

Parameter

<num> Long - Number of channels.
 <value> Long - Value of the questionable limit channel additional status event register.

Example `STATus:QUEStionable:LIMit:CHANnel2:EChannel:EVENT?`

Query Syntax `STATUS:QUEStionable:LIMit:CHANnel<num>:EChannel:EVENT?`

Overlapping? No

Default 1

STATus:QUEStionable:LIMit:CHANnel<num>:EChannel:NTRansition

(Read-Write) Set/get the value of the negative transition filter of the “questionable limit channel additional status register” of specified channel.

Parameter

<num> Long - Number of channels.
 <value> Long - Value of the negative transition filter. 0 to 65535, bit 0, bit 3 to bit 15 cannot be set to 1, default to 0.

Example `STATus:QUEStionable:LIMit:CHANnel1:EChannel:NTRansition 16`

Query Syntax `STATUS:QUEStionable:LIMit:CHANnel<num>:EChannel:NTRansition?`

Overlapping? No

Default 1

STATus:QUEStionable:LIMit:CHANnel<num>:EChannel:PTRansition

(Read-Write) Set/get the value of the positive transition filter of the “questionable bandwidth limit channel additional status register” of specified channel.

Parameter

<num> Long - Number of channels.
 <value> Long - Value of the positive transition filter. 0 to 65535, bit 0, bit 3 to bit 15 cannot be set to 1.

Example `STATus:QUEStionable:LIMit:CHANnel2:ECHannel:PTRansition 16`

Query Syntax `STATUS:QUEStionable:LIMit:CHANnel<cnum>:ECHannel:PTRansition?`

Overlapping? No

Default 1

STATus:QUEStionable:LIMit:CHANnel<cnum>:ENABLE

(Read-Write) Set/get the value of the “questionable limit channel status enabling register” of specified channel.

Parameter

<cnum> Long - Number of channels.

<value> Long - Value of the questionable limit channel status enabling register. 0 to 65535, bit 15 cannot be set to 1.

Example `STATus:QUEStionable:LIMit:CHANnel:ENABLE 16`

Query Syntax `STATUS:QUEStionable:LIMit:CHANnel<cnum>:ENABLE?`

Overlapping? No

Default 1

STATus:QUEStionable:LIMit:CHANnel<cnum>:EVENT

(Read only) Read the value of the “questionable limit channel status event register” of specified channel.

Parameter

<cnum> Long - Number of channels.

<value> Long - Value of the questionable limit channel status event register.

Example `STATus:QUEStionable:LIMit:CHANnel :EVENT?`

Query Syntax `STATUS:QUEStionable:LIMit:CHANnel<cnum>:EVENT?`

Overlapping? No

Default 1

STATus:QUEStionable:LIMit:CHANnel<cnum>:NTRansition

(Read-Write) Set/get the value of the positive transition filter of the “questionable limit channel status register” of specified channel.

Parameter

<cnum> Long - Number of channels.

<value> Long - Value of the negative transition filter. 0 to 65535, default to 0.

Example

```
STATus:QUEStionable:LIMit:CHANnel2:NTRansition 16
```

Query Syntax

```
STATUS:QUEStionable:LIMit:CHANnel<cnum>:NTRansition?
```

Overlapping? No

Default 1

STATus:QUEStionable:LIMit:CHANnel<cnum>:PTRansition

(Read-Write) Set/get the value of the positive transition filter of the “questionable limit channel status register” of specified channel.

Parameter

<cnum> Long - Number of channels.

<value> Long - Value of the positive transition filter. 0 to 65535, bit 15 cannot be set to 1.

Example

```
STATus:QUEStionable:LIMit:CHANnel2:PTRansition 16
```

Query Syntax

```
STATUS:QUEStionable:LIMit:CHANnel<cnum>:PTRansition?
```

Overlapping? No

Default 1

STATus:QUEStionable:LIMit:CONDition

(Read only) Read the value of the questionable limit additional status condition register.

Parameter

<value> Long - Value of the questionable limit additional status condition register.

Example

```
STATus:QUEStionable:LIMit:CONDition?
```

Query Syntax `STATUS:QUESTIONable:LIMit:CONDition?`

Overlapping? No

Default NONE

STATUS:QUESTIONable:LIMit:ELIMit:CONDition

(Read-Write) Read the value of the questionable limit additional status condition register.

Parameter

<value> Long - Value of the questionable limit additional status condition register.

Example `STATUS:QUESTIONable:LIMit:ELIMit:CONDition 16`

Query Syntax `STATUS:QUESTIONable:LIMit:ELIMit:CONDition?`

Overlapping? No

Default NONE

STATUS:QUESTIONable:LIMit:ELIMit:ENABLE

(Read-Write) Set/get the value of the questionable limit additional status enabling register.

Parameter

<value> Long - Value of the questionable limit additional status enabling register. 0 to 65535, bit 0, bit 3 to bit 15 cannot be set to 1.

Example `STATUS:QUESTIONable:LIMit:ELIMit:ENABLE 6`

Query Syntax `STATUS:QUESTIONable:LIMit:ELIMit:ENABLE?`

Overlapping? No

Default NONE

STATUS:QUESTIONable:LIMit:ELIMit:EVENT

(Read only) Read the value of the questionable limit additional status event register.

Parameter

<value> Long - Value of the questionable limit additional status event register.

Example `STATus:QUEStionable:LIMit:ELIMit:EVENT?`

Query Syntax `STATUS:QUEStionable:LIMit:ELIMit:EVENT?`

Overlapping? No

Default NONE

STATus:QUEStionable:LIMit:ELIMit:NTRansition

(Read-Write) Set/get the value of the negative transition filter of the questionable limit additional status register.

Parameter

<value> Long - Value of the negative transition filter. 0 to 65535, bit 0, bit 3 to bit 15 cannot be set to 1.

Example `STATus:QUEStionable:LIMit:ELIMit:NTRansition 16`

Query Syntax `STATUS:QUEStionable:BLIMit:ELIMit:NTRansition?`

Overlapping? No

Default 0

STATus:QUEStionable:LIMit:ELIMit:PTRansition

(Read-Write) Set/get the value of the positive transition filter of the questionable bandwidth limit additional status register.

Parameter

<value> Long - Value of the positive transition filter. 0 to 65535, bit 0, bit 3 to bit 15 cannot be set to 1.

Example `STATus:QUEStionable:LIMit:ELIMit:PTRansition ?`

Query Syntax `STATUS:QUEStionable:LIMit:ELIMit:PTRansition?`

Overlapping? No

Default NONE

STATus:QUEStionable:LIMit:ENABle

(Read-Write) Set/get the value of the questionable limit status enabling register.

Parameter

<value> Long - Value of the questionable limit status enabling register. 0 to 65535, bit 15 cannot be set to 1.

Example `STATus:QUEStionable:LIMit:ENABle 6`

Query Syntax `STATUS:QUEStionable:LIMit:ENABle?`

Overlapping? No

Default NONE

STATus:QUEStionable:LIMit:EVENT

(Read only) Read the value of the questionable limit status event register.

Parameter

<value> Long - Value of the questionable limit status event register.

Example `STATus:QUEStionable:LIMit:EVENT?`

Query Syntax `STATUS:QUEStionable:LIMit:EVENT?`

Overlapping? No

Default NONE

STATus:QUEStionable:LIMit:NTRansition

(Read-Write) Set/get the value of the negative transition filter of the questionable limit status register.

Parameter

<value> Long - Value of the negative transition filter of the questionable limit status register. 0 to 65535, bit 0, bit 3 to bit 15 cannot be set to 1.

Example `STATus:QUEStionable:LIMit:NTRansition 6`

Query Syntax `STATUS:QUEStionable:LIMit:NTRansition?`

Overlapping? No

Default 0

STATus:QUEStionable:LIMit:PTRansition

(Read-Write) Set/get the value of the positive transition filter of the questionable limit status register.

Parameter

<value> Long - Value of the positive transition filter of the questionable bandwidth limit status register. 0 to 65535, bit 15 cannot be set to 1.

Example `STATus:QUEStionable:LIMit:PTRansition 6`

Query Syntax `STATUS:QUEStionable:LIMit:PTRansition?`

Overlapping? No

Default NONE

STATus:QUEStionable:NTRansition

(Read-Write) Set/get the value of the negative transition filter of the questionable status register.

Parameter

<value> Long - Value of the negative transition filter. 0 to 65535, bits (0 to 9) and bits (11 to 15) cannot be set to 1.

Example `STATus:QUEStionable:NTRansition 6`

Query Syntax `STATUS:QUEStionable:NTRansition?`

Overlapping? No

Default 0

STATus:QUEStionable:PTRansition

(Read-Write) Set/get the value of the positive transition filter of the questionable status register.

Parameter

<value> Long - Value of the positive transition filter. 0 to 65535, bit 0 to bit 9. Bit 11 to bit 13 and bit 11 to bit 15 cannot be set to 1.

Example `STATus:QUEStionable:PTRansition 6`

Query Syntax `STATUS:QUEStionable:PTRansition?`

Overlapping? No

Default 0

STATus:QUEStionable:RLIMit:CHANnel<cnum>:CONDition

(Read only) Read the value of the questionable wave limit channel status condition register of specified channel.

Parameter

<cnum> Long - Number of channels.

<value> Long - Value of the questionable wave limit channel status condition register.

Example `STATus:QUEStionable:RLIMit:CHANnel:CONDition?`

Query Syntax `STATUS:QUEStionable:RLIMit:CHANnel<cnum>:CONDition?`

Overlapping? No

Default 1

STATus:QUEStionable:RLIMit:CHANnel<cnum>:ECHANnel:CONDition

(Read-Write) Read the value of the questionable wave limit channel status condition register of specified channel.

Parameter

<cnum> Long - Number of channels.

<value> Long - Value of the questionable wave limit channel additional event register.

Example `STATus:QUEStionable:RLIMit:CHANnel:ECHANnel:NDition?`

Query Syntax `STATUS:QUEStionable:RLIMit:CHANnel<cnum>:ECHANnel:CONDition?`

Overlapping? No

Default 1

STATus:QUEStionable:RLIMit:CHANnel<cnum>:ECHannel:ENABLE

(Read-Write) Set/get the value of the questionable wave limit channel additional status enabling register of specified channel.

Parameter

<cnum> Long - Number of channels.

<value> Long - Value of the enabling register. 0 to 65535, bit 0, bit 3 to bit 15 cannot be set to 1.

Example

```
STATus:QUEStionable:RLIMit:CHANnel:ECHannel:ENABLE 16
```

Query Syntax STATUS:QUEStionable:RLIMit:CHANnel<cnum>:ECHannel:ENABLE?

Overlapping? No

Default 1

STATus:QUEStionable:RLIMit:CHANnel<cnum>:ECHannel:EVENT

(Read only) Read the value of the “questionable wave limit channel additional status event register” of specified channel.

Parameter

<cnum> Long - Number of channels.

<value> Long - Value of the questionable wave limit channel additional event register.

Example

```
STATus:QUEStionable:RLIMit:CHANnel:ECHannel:EVENT?
```

Query Syntax STATUS:QUEStionable:RLIMit:CHANnel<cnum>:ECHannel:EVENT?

Overlapping? No

Default 1

STATus:QUEStionable:RLIMit:CHANnel<cnum>:ECHannel:NTRansition

(Read-Write) Set/get the value of the negative transition filter of the “questionable wave channel additional status register” of specified channel.

Parameter

<cnum> Long - Number of channels.

<value> Long - Value of the negative transition filter. 0 to 65535, bit 0, bit 3 to bit 15 cannot be

set to 1, default to 0.

Example `STATUS:QUESTIONable:RLIMit:CHANnel:ECHannel:NTRansition 16`

Query Syntax `STATUS:QUESTIONable:RLIMit:CHANnel<cnum>:ECHannel:NTRansition?`

Overlapping? No

Default 1

STATUS:QUESTIONable:RLIMit:CHANnel<cnum>:ECHannel:PTRansition

(Read-Write) Set/get the value of the positive transition filter of the “questionable wave limit channel additional status register” of specified channel.

Parameter

<cnum> Long - Number of channels.

<value> Long - Value of the positive transition filter. 0 to 65535, bit 0, bit 3 to bit 15 cannot be set to 1.

Example `STATUS:QUESTIONable:RLIMit:CHANnel:ECHannel:PTRansition 16`

Query Syntax `STATUS:QUESTIONable:RLIMit:CHANnel<cnum>:ECHannel:PTRansition?`

Overlapping? No

Default 1

STATUS:QUESTIONable:RLIMit:CHANnel<cnum>:ENABLE

(Read-Write) Set/get the value of the “questionable wave limit channel status enabling register” of specified channel.

Parameter

<cnum> Long - Number of channels.

<value> Long - Value of the questionable wave limit channel status enabling register. 0 to 65535, bit 15 cannot be set to 1.

Example `STATUS:QUESTIONable:RLIMit:CHANnel:ENABLE 6`

Query Syntax `STATUS:QUESTIONable:RLIMit:CHANnel<cnum>:ENABLE?`

Overlapping? No
 Default 1

STATUS:QUESTIONable:RLIMit:CHANnel<cnum>:EVENT

(Read only) Read the value of the “questionable wave limit channel status event register” of specified channel.

Parameter

<cnum> Long - Number of channels.
 <value> Long - Value of the questionable wave limit channel status event register.

Example `STATUS:QUESTIONable:BLIMit:CHANnel:EVENT?`

Query Syntax `STATUS:QUESTIONable:BLIMit:CHANnel<cnum>:EVENT?`

Overlapping? No
 Default 1

STATUS:QUESTIONable:BLIMit:CHANnel<cnum>:NTRansition

(Read-Write) Set/get the value of the positive transition filter of the “questionable wave limit channel status register” of specified channel.

Parameter

<cnum> Long - Number of channels.
 <value> Long - Value of the negative transition filter. 0 to 65535, default to 0.

Example `STATUS:QUESTIONable:RLIMit:CHANnel:NTRansition 6`

Query Syntax `STATUS:QUESTIONable:RLIMit:CHANnel<cnum>:NTRansition?`

Overlapping? No
 Default 1

STATUS:QUESTIONable:RLIMit:CHANnel<cnum>:PTRansition

(Read-Write) Set/get the value of the positive transition filter of the “questionable wave limit channel status register” of specified channel.

Parameter

<cnum>	Long - Number of channels.
<value>	Long - Value of the positive transition filter. 0 to 65535, bit 15 cannot be set to 1.

Example	<code>STATus:QUEStionable:RLIMit:CHANnel:PTRansition 6</code>
---------	---

Query Syntax	<code>STATUS:QUEStionable:RLIMit:CHANnel<cnum>:PTRansition?</code>
--------------	--

Overlapping?	No
--------------	----

Default	1
---------	---

STATus:QUEStionable:RLIMit:CONDition

(Read only) Read the value of the questionable wave additional status condition register.

Parameter

<value>	Long - Value of the questionable wave limit additional status condition register.
---------	---

Example	<code>STATus:QUEStionable:RLIMit:CONDition?</code>
---------	--

Query Syntax	<code>STATUS:QUEStionable:RLIMit:CONDition?</code>
--------------	--

Overlapping?	No
--------------	----

Default	NONE
---------	------

STATus:QUEStionable:RLIMit:ELIMit:CONDition

(Read only) Read the value of the questionable wave additional status condition register.

Parameter

<value>	Long - Value of the questionable wave limit additional status condition register.
---------	---

Example	<code>STATus:QUEStionable:BLIMit:ELIMit:CONDition 6</code>
---------	--

Query Syntax	<code>STATUS:QUEStionable:BLIMit:ELIMit:CONDition?</code>
--------------	---

Overlapping?	No
--------------	----

Default	NONE
---------	------

STATus:QUEStionable:BLIMit:ELIMit:ENABLE

(Read-Write) Set/get the value of the questionable wave limit additional status enabling register.

Parameter

<value> Long - Value of the questionable wave limit additional status enabling register. 0 to 65535, bit 0, bit 3 to bit 15 cannot be set to 1.

Example `STATus:QUEStionable:RLIMit:ELIMit:ENABLE 16`

Query Syntax `STATUS:QUEStionable:RLIMit:ELIMit:ENABLE?`

Overlapping? No

Default NONE

STATus:QUEStionable:RLIMit:ELIMit:EVENT

(Read only) Read the value of the questionable wave limit additional status event register.

Parameter

<value> Long - Value of the questionable wave limit additional event register.

Example `STATus:QUEStionable:RLIMit:ELIMit:EVENT?`

Query Syntax `STATUS:QUEStionable:RLIMit:ELIMit:EVENT?`

Overlapping? No

Default NONE

STATus:QUEStionable:RLIMit:ELIMit:NTRansition

(Read-Write) Set/get the value of the negative transition filter of the questionable wave limit additional status register.

Parameter

<value> Long - Value of the negative transition filter. 0 to 65535, bit 0, bit 3 to bit 15 cannot be set to 1.

Example `STATus:QUEStionable:RLIMit:ELIMit:NTRansition 16`

Query Syntax `STATUS:QUEStionable:RLIMit:ELIMit:NTRansition?`

Overlapping?	No
Default	0

STATUS:QUESTIONABLE:RLIMIT:ELIMIT:PTRANSITION

(Read-Write) Set/get the value of the positive transition filter of the questionable wave limit additional status register.

Parameter

<value> Long - Value of the positive transition filter. 0 to 65535, bit 0, bit 3 to bit 15 cannot be set to 1.

Example `STATUS:QUESTIONABLE:RLIMIT:ELIMIT:PTRANSITION 16`

Query Syntax `STATUS:QUESTIONABLE:RLIMIT:ELIMIT:PTRANSITION?`

Overlapping?	No
Default	NONE

STATUS:QUESTIONABLE:RLIMIT:ENABLE

(Read-Write) Set/get the value of the questionable wave limit status enabling register.

Parameter

<value> Long - Value of the questionable wave limit status enabling register. 0 to 65535, bit 15 cannot be set to 1.

Example `STATUS:QUESTIONABLE:RLIMIT:ENABLE 6`

Query Syntax `STATUS:QUESTIONABLE:RLIMIT:ENABLE?`

Overlapping?	No
Default	NONE

STATUS:QUESTIONABLE:RLIMIT:EVENT

(Read only) Read the value of the questionable bandwidth limit status event register.

Parameter

<value> Long - Value of the questionable wave limit status event register.

Example	<code>STATus:QUEStionable:RLIMit:EVENT?</code>
---------	--

Query Syntax	<code>STATUS:QUEStionable:RLIMit:EVENT?</code>
--------------	--

Overlapping?	No
--------------	----

Default	NONE
---------	------

STATus:QUEStionable:RLIMit:NTRansition

(Read-Write) Set/get the value of the negative transition filter of the questionable wave limit status register.

Parameter

<value> Long - Value of the negative transition filter of the questionable wave limit status register. 0 to 65535, bit 0, bit 3 to bit 15 cannot be set to 1.

Example	<code>STATus:QUEStionable:RLIMit:NTRansition 6</code>
---------	---

Query Syntax	<code>STATUS:QUEStionable:RLIMit:NTRansition?</code>
--------------	--

Overlapping?	No
--------------	----

Default	0
---------	---

STATus:QUEStionable:RLIMit:PTRansition

(Read-Write) Set/get the value of the positive transition filter of the questionable wave limit status register.

Parameter

<value> Long - Value of the positive transition filter of the questionable wave limit status register. 0 to 65535, bit 15 cannot be set to 1.

Example	<code>STATus:QUEStionable:RLIMit:PTRansition 6</code>
---------	---

Query Syntax	<code>STATUS:QUEStionable:RLIMit:PTRansition?</code>
--------------	--

Overlapping?	No
--------------	----

Default	NONE
---------	------

System Commands

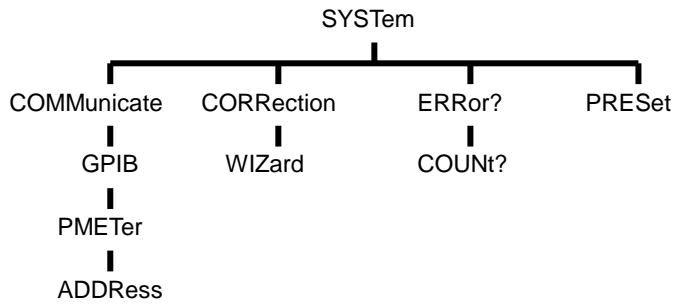

The below commands are only available in 1.2.0 or above.

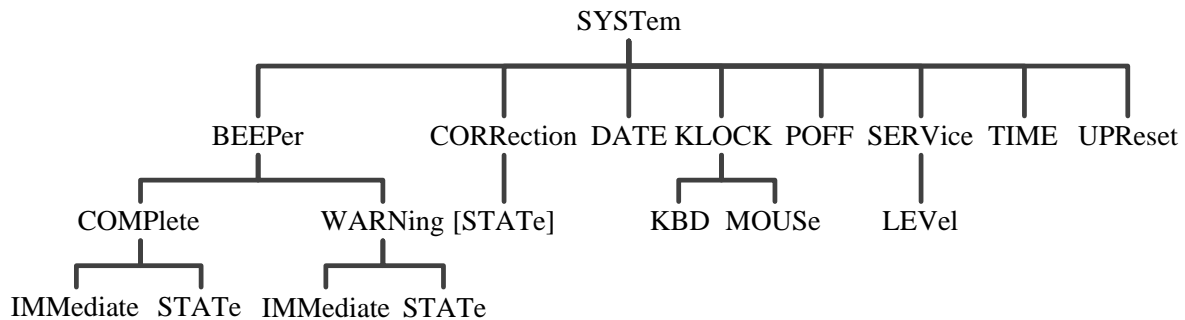

SYSTEM:COMMunicate:GPIB:PMETer:ADDRess <num> (Not supported)

(Read-Write) Specify the power meter GPIB address during source power calibration.

Parameter

<num> Power meter GPIB address, with value range of 0 to 30.

Example

```

SYSTEM:COMM:GPIB:PMET:ADDR 13
system:communicate:gpiib:pmet:address 14
  
```

Query Syntax SYSTEM:COMMunicate:GPIB:PMETer:ADDRess?

Return Type Char

Overlapping? No

Default 13

SYSTEM:CORRection:WIZard <char>

(Write only) Run calibration guidance or dialogue box of installing calibration kit.

Parameter

<char> Select:

MAIN - Calibration guidance.
 CKIT - Dialogue box of installing calibration kit.
 Both display the operation interface on the screen.

Example `SYST:CORR:WIZ MAIN system:correction:wizard ckit`

Query Syntax NONE

Overlapping? No

Default NONE

SYSTem:ERRor?

(Read only) Return the next error on the error queue. The analyzer will write the error messages to the error list when occurred, and then remove a error message to the output queue after receiving SYSTEM:ERROR? command, where the error messages are put into the output queue in the receiving order. In case of the following conditions, it will clear the error list:

Startup.

Perform *CLS commands.

Read all error messages.

Example `SYST:ERR? system:error?`

Overlapping? No

Default NONE

SYSTem:ERRor:COUNt?

(Read only) Return the error number in the error list. Use SYST:ERR? command to read error message.

Example `SYST:ERR:COUN? system:error:count?`

Overlapping? No

Default NONE

SYSTem:PRESet

(Write only) Reset the system.

1. Delete all traces, measurements and windows.
2. Reset to the default status.
3. Create a S11 measurement named "CH1_WIN1_LINE1_PARAM1".

Example `SYST:PRES system:preset`

Overlapping?	No
Default	NONE

These commands are compatible with Agilent ENA series programming commands.

SYSTem:BEEPer:COMPLete:IMMediate

(Write only) Beep to notify the operation is completed.

Example `SYST:BEEP:COMP:IMM system:beeper:complete:immediate`

Query Syntax NONE

Overlapping?	No
Default	NONE

SYSTem:BEEPer:COMPLete:STATe <ON|OFF>

(Read-Write) Turn on/off or return the buzzer status notifying the operation is completed.

Parameter

<ON|OFF> Turn on/off the buzzer notifying the operation is completed.
 ON: Turn on the buzzer notifying the operation is completed.
 OFF: Turn off the buzzer notifying the operation is completed.

Example `SYST:BEEP:COMP:STAT ON`
`system:beeper:complete:state off`

Query Syntax `SYSTem:BEEPer:COMPLete:STATe?`

Return Type Boolean

Overlapping?	No
Default	ON

SYSTem:BEEPer:WARNing:IMMediate

(Write only) Beep to notify warning/limit test result.

Example `SYST:BEEP:WARN:IMM system:beeper:warning:immediate`

Query Syntax NONE

Overlapping?	No
--------------	----

Default NONE

SYSTem:BEEPer:WARNing:STATe <ON|OFF>

(Read-Write) Turn on/off or return the buzzer status notifying warning/limit test result.

Parameter

<ON|OFF> Turn on/off the buzzer notifying warning/limit test result
 ON: Turn on the buzzer notifying warning/limit test result.
 OFF: Turn off the buzzer notifying warning/limit test result.

Example

```
SYST:BEEP:WARN:STAT ON
system:beeper:warning:state off
```

Query Syntax SYSTem:BEEPer:WARNing:STATe?

Return Type Boolean

Overlapping? No

Default ON

SYSTem:CORRection[:STATe] <ON|OFF>

(Read-Write) Turn on/off or return system correction status.

Parameter

<ON|OFF> ON: Turn on system correction.
 OFF: Turn off system correction.

Example

```
SYST:CORR ON
system:correction:state off
```

Query Syntax SYSTem:CORRection:STATe?

Return Type Boolean

Overlapping? No

Default ON

SYSTem:DATE <data>

(Read-Write) Set/get the data of built-in clock of AV3656A.

Parameter

Specify 3-element array data (date of built-in clock)
 <data> Data (0): set Year From 1980 to 2099
 Data (1): set Month. From 1 to 12
 Data (2): set Data,. From 1 to 31

Example

```
SYST:DATE 2012,1,1
system:date 2012,12,25
```

Query Syntax SYSTem:DATE?

Return Type <num1>,<num2>,<num3> (Y, M, D)

Overlapping? No

Default NONE

SYSTem:ERRor <Not Supported Temporarily>

(Read only) Read the earliest stored error in the error list of error queue of AV3656A.

Example

```
SYSTem:ERRor?
```

Query Syntax SYSTem:ERRor?

Return Type <num1>,<num2>
 <num1>: Error quantity
 <num2>: Error message

Overlapping? No

Default NONE

SYSTem:KLOCK:kBD <ON|OFF>

(Read-Write) Set/get whether to lock the operation on front panel (key and knob) and keyboard.

Parameter

<ON|OFF> ON: specify locking.
 OFF: specify unlocking.

Example

```
SYST:KLOC:kBD OFF
system:klock:kbd on
```

Query Syntax	SYSTem:KLOCK:KBD?
Return Type	Boolean

Overlapping?	No
Default	OFF

SYSTem:KLOCK:MOUSE <ON|OFF>

(Read-Write) Set/get whether to lock the operation on mouse and touch screen.

Parameter

<ON OFF>	ON: specify locking. OFF: specify unlocking.
----------	---

Example

```
SYST:KLOC:MOUS OFF
system:klock:mouse on
```

Query Syntax	SYSTem:KLOCK:MOUSE?
Return Type	Boolean

Overlapping?	No
Default	OFF

SYSTem:POFF

(Write only) Turn off AV3656A.

Example

```
SYSTem:POFF
```

Overlapping?	No
Default	NONE

SYSTem:SECurity:LEVEL <char>

(Read-Write) Set/get the security level of AV3656A.

Parameter

<char>	Security level "NONE": specify to turn off security level. "LOW": specify low security level. "HIGH": specify high security level.
--------	---

Example	<code>SYSTem:SECurity:LEVel LOW</code> <code>system:security:level high</code>
---------	---

Query Syntax	<code>SYSTem:SECurity:LEVel?</code>
--------------	-------------------------------------

Return Type	Char
-------------	------

Overlapping?	No
--------------	----

Default	"NONE"
---------	--------

SYSTem:SERvice

(Read only) Read whether AV3656A is in service mode.

Example	<code>SYST:SERV?</code>
---------	-------------------------

Query Syntax	<code>SYSTem:SERvice?</code>
--------------	------------------------------

Return Type	Boolean ON: in service mode OFF: not in service mode.
-------------	---

Overlapping?	No
--------------	----

Default	OFF
---------	-----

SYSTem:TIME <data>

(Read-Write) Set/get the time of built-in clock of AV3656A.

Parameter

<data>	Specify 3-element array data (date of built-in clock) Data (0): set Hour (on the basis of 24h). From 0 to 23 Data (1): set Minute. From 0 to 59 Data (2): set Second. From 0 to 59
--------	---

Example	<code>SYST:TIME 13,10,0</code> <code>system:time 17,56,20</code>
---------	---

Query Syntax	<code>SYSTem: TIME?</code>
--------------	----------------------------

Return Type	<num1>,<num2>,<num3> (h, m, s)
-------------	--------------------------------

Overlapping? No
 Default NONE

SYSTem:UPReset

(Write only) Preset AV3656A via user setting.

Example `SYSTem:UPReset`

Overlapping? No
 Default NONE

Trigger Commands

Starting or ending measurement sequence. Such commands are an important part of synchronous measurement.

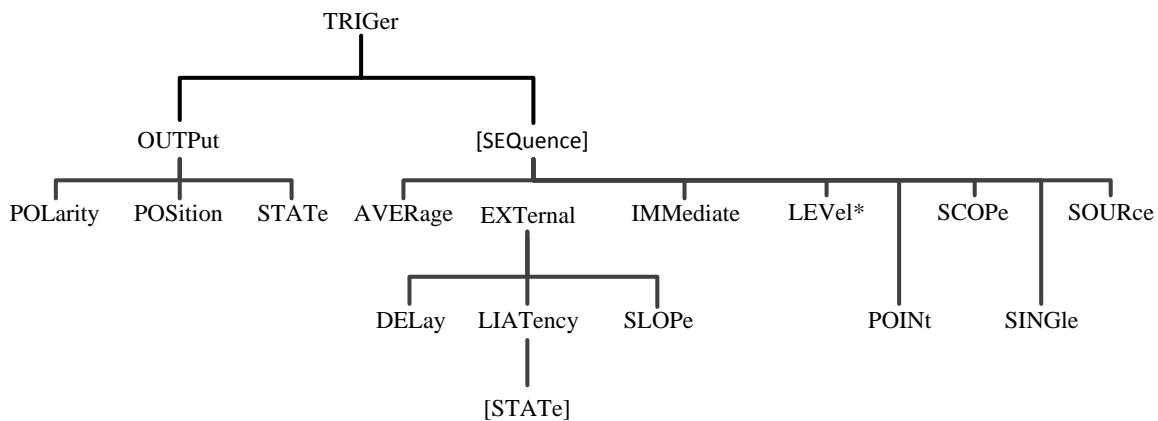

TRIGger[:SEQuence]:LEVel <char>

(Read-Write) Set to trigger signal at high level or low level (edge triggering mode not supported at present). This command is valid only by executing the TRIG:SOURce EXTernal command to set the trigger source to external source.

Parameter

<char> Select:
 HIGH - TTL triggering at high level.
 LOW - TTL triggering at low level.

Example `TRIG:LEV HIGH`
`trigger:sequence:level low`

Query Syntax `TRIGger[:SEQuence]:LEVel?`

Return Type	Char
-------------	------

Overlapping?	No
--------------	----

Default	LOW
---------	-----

TRIGger[:SEQuence]:SCOPE <char>

(Read-Write) Set triggering range. Trigger all channels or the current channel.

Parameter

Options:

<char>

ALL - All channels. It is also required to execute the SENS:SWEep:TRIG:POINT OFF command for all channels.

CURRent - Triggering one channel at a time. Turn to the next triggerable channel after completion of each triggering. The CURRent parameter can only be used after executing the TRIG:SOURCE = MANual command.

Example

```
TRIG:SCOP ALL
trigger:sequence:scope current
```

Query Syntax	TRIGger[:SEQuence]:SCOPE?
--------------	---------------------------

Return Type	Char
-------------	------

Overlapping?	No
--------------	----

Default	ALL
---------	-----

TRIGger[:SEQuence]:SOURce <char>

(Read-Write) Set to trigger the signal source with sweep. This command is a superset of the INITiate:CONTinuous command, and the INITiate command cannot set the source to external mode.

Parameter

Select:

<char>

EXTernal - External source (rear panel).

IMMEDIATE - Internal source generating continuous triggering signals.

MANual - Send a triggering signal with the "trigger" button on the front panel or by sending the INIT:IMM command.

Example

```
TRIG:SOUR EXT
trigger:sequence:source immediate
```

Query Syntax	TRIGger[:SEQuence]:SOURce?
--------------	----------------------------

Return Type	Char
-------------	------

Overlapping?	No
--------------	----

Default	IMMEDIATE
---------	-----------

Note: The below commands are only available in 1.2.0 or above.

TRIGger:OUTPut:POLarity <char>

(Read-Write) Set/get the polarity of the pulse generated by external trigger output port.

Parameter

	Set/get the polarity of pulse generated by output trigger.
<char>	“POSitive”: Generate positive pulse. “NEGative”: generating negative pulse.

Example

```
TRIG:OUTP:POL POS
trigger:output:polarity negative
```

Query Syntax	TRIGger:OUTPut:POLarity?
--------------	--------------------------

Return Type	Char
-------------	------

Overlapping?	No
--------------	----

Default	“POSitive”
---------	------------

TRIGger:OUTPut:POSition <char>

(Read-Write) Set/get the position of external trigger output port.

Parameter

	Set/get the position of the output trigger (after or before the measurement point).
<char>	“AFTer”: Pulse after generating the measurement point (trigger). “BEFore”: Pulse before generating the measurement point (trigger).

Example

```
TRIG:OUTP:POS BEF
trigger:output:position after
```

Query Syntax	TRIGger:OUTPut:POSition?
--------------	--------------------------

Return Type	Char
-------------	------

Overlapping?	No
--------------	----

Default “AFTer”

TRIGger:OUTPut:STATe <ON|OFF>

(Read-Write) Set/get the status of external trigger output port.

Parameter

<ON|OFF> Set/get external trigger output status.
 ON (true or on): Turn on the external trigger output.
 OFF (false or off): Turn off the external trigger output.

Example

```
TRIG:OUTP:STAT OFF
trigger:output:state on
```

Query Syntax TRIGger:OUTPut:STATe?

Return Type Boolean

Overlapping? No

Default OFF

TRIGger[:SEQuence]:AVERage <ON|OFF>

(Read-Write) The sweep function must be set to ON when the averaging trigger function is ON.

Parameter

<ON|OFF> Turn ON/OFF the averaging trigger status.
 ON (true or on): Turn on the Averaging trigger.
 OFF (false or off): Turn off the Averaging trigger.

Example

```
TRIG:AVER ON
trigger:sequence:average off
```

Query Syntax TRIGger:SEQuence:AVERage?

Return Type Boolean

Overlapping? No

Default OFF

TRIGger[:SEQuence]:EXTernal:DELay <value>

(Read-Write) Set/get the time required from receiving trigger to measurement starting when the trigger

source is external.

Parameter

<value> External trigger time delay, 0 to 1.

Example `TRIGger:SEQuence:EXTernal:DELay 0.05`

Query Syntax `TRIGger:SEQuence:EXTernal:DELay?`

Return Type Char

Overlapping? No

Default 0

TRIGger[:SEQuence]:EXTernal:LLATency[:STATe] <ON|OFF> <Not Achievable Temporarily>

(Read-Write) Turn on/off or return low time delay external trigger status. (When the low-time-delay external trigger function is turned on, the point trigger function must be set to on and the trigger source set to external trigger.)

Parameter

<ON|OFF> Turn on/off low-time-delay external trigger.
 ON: Turn on low-time-delay external trigger.
 OFF: Turn off low-time-delay external trigger.

Example `TRIG:EXT:LLAT ON`
`trigger:sequence:external:llatency:state off`

Query Syntax `TRIGger:SEQuence:EXTernal:LLATency:STATe?`

Return Type Boolean

Overlapping? No

Default OFF

TRIGger[:SEQuence]:EXTernal:SLOPe <char>

(Read-Write) Set/get the polarity of the input port of external trigger.

Parameter

<char> Set/get the polarity of the external input trigger.
 "POSitive": Set/get positive pole.
 "NEGative": Set/get negative pole.

Example	TRIG:EXT:SLOP POS trigger:sequence:external:slope negative
---------	---

Query Syntax	TRIGger:SEQuence:EXTernal:SLOPe?
--------------	----------------------------------

Return Type	Char
-------------	------

Overlapping?	No
--------------	----

Default	“NEGative”
---------	------------

TRIGger[:SEQuence]:IMMediate

(Write only) This command can immediately generate a trigger and execute a measurement regardless of the trigger mode setting.

Example	TRIGger:SEQuence:IMMediate
---------	----------------------------

Query Syntax	TRIGger:SEQuence:IMMediate
--------------	----------------------------

Overlapping?	No
--------------	----

Default	NONE
---------	------

TRIGger[:SEQuence]:POINt <ON|OFF>

(Read-Write) Turns ON/OFF or returns to the state of the single-point trigger status.

Parameter

<ON OFF>	Turn ON/OFF point trigger. ON: Turn on point trigger. OFF: Turn off point trigger.
----------	--

Example	TRIG:POIN ON trigger:sequence:point off
---------	--

Query Syntax	TRIGger:SEQuence:POINt?
--------------	-------------------------

Return Type	Boolean
-------------	---------

Overlapping?	No
--------------	----

Default	OFF
---------	-----

TRIGger[:SEQuence]:SINGle

(Write only) This command can immediately generate a trigger and execute a measurement regardless of the trigger mode setting.

Example `TRIGger:SEQuence:SINGle`

Query Syntax `TRIGger:SEQuence:SINGle`

Overlapping? No

Default NONE

TRIGger[:SEQuence]:SOURce <char>

(Read-Write) Set/get trigger source.

This commands is compatible with Agilent E5071 command.

Parameter

<char> Trigger source
 "INTernal": internal trigger is specified.
 "EXTernal": external trigger is specified.
 "MANual": manual trigger is specified.
 "BUS": bus trigger is specified.

Example `TRIG:SOUR MAN`
`trigger:sequence:source internal`

Query Syntax `TRIGger:SEQuence:SOURce?`

Return Type char

Overlapping? No

Default "INTernal"

Chapter 4 Error Description

This chapter mainly introduces the display and handling mechanisms of error messages of 3656 series vector network analyzers, the classification methods and principle of errors as well as details about the errors that can be handled by this series of vector network analyzers.

- ◆ Overview of error messages
- ◆ Formats of error messages
- ◆ Types of error messages
- ◆ Details of error messages

Section 1 Overview of Error Messages

When an error occurs in a vector network analyzer, both the SCPI (remote interface) error queue and the front panel display error queue will report an error. The two queues are independent of each other in terms of display and handling. For details on the front panel error queue, please refer to the user manual.

When using the SCPI (remote interface) error queue to access the error message, the error code and <error description> responded by the error queue are displayed on the host terminal.

Table 4-1 Summary of error handling of the front panel and the remote control interface

Item	Error message queue of the front panel	Error message queue of the SCPI remote control interface
Queue length (maximum number of saved error messages)	50	50
Handling upon overflow	Circular handling (overwriting old errors with new ones)	Circular handling (overwriting old errors with new ones)
View all errors	With the Help menu: [Error Message] - [View Error Log]	With SCPI query command: SYSTem:ERRor[:NEXT]?
Clear queue	Can't be cleared	The errors in the error queue of the remote control interface can be cleared in the following three ways: The instrument is powered on again *CLS command is sent The last error is queried
Handling of instrument fault information	Re-reporting after error message queue is cleared	Re-reporting after error message queue is cleared

Section 2 Formats of Error Messages

When the front panel displays an error message, it will display an error code and the error type and possibly a description of the error message (depending on the specific error).

The format of an error message is shown in the figure below.

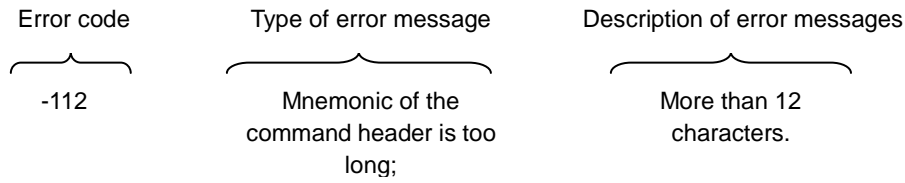

In addition, Section 4 this chapter offers details about the error code of each error, type of the error information, and related information about the error are given in detail.

Section 3 Type of Error Messages

The error handling mechanism in this series of vector network analyzers is the multiple error recording mode, that is, an event may cause multiple errors. If the instrument receives the command "*IDN ?", the instrument will generate two errors, "query only" and "command cannot be executed".

4.3.1 Query errors

When the device output queue controller detects an information exchange problem as described in IEEE 488.2. This type of errors set the query error bit (bit 2) of the event status register (IEEE 488.2, Section 11.5.1). This type of errors correspond to message exchange protocol error described in IEEE 488.2, 6.5. Query errors occur in the following cases:

- 1) Trying to read from output queue without data.
- 2) Data in output queue is lost

4.3.2 Devices-related errors

They indicate that the operation of the device has not been complete successfully, possibly due to a hardware failure or a firmware error. These codes are also used for self-test response errors. This type of errors set the device-related error bit (bit 3) of the event status register (IEEE 488.2). This type of errors are not defined in detail in SCPI and are defined by the instrument manufacturers based on the operation of the hardware, firmware, and software of the instrument.

4.3.3 Execution errors

They indicate that the execution control module of the device has detected errors. This type of errors set the execution error bit (bit 4) of the event status register (IEEE 488.2, Section 11.5.1).

4.3.4 Command errors

They indicate that the interpreter has detected syntax error of IEEE 488.2. This type of errors set the command error bit (bit 5) of the event status register (IEEE 488.2, Section 11.5.1).

Section 4 Details of error messages

The following are samples and descriptions of the error messages:

512

"The secondary parameters of the calibration status (power, IF bandwidth, scan time, step mode) have changed."

Prompt

Additional information: Changing such secondary parameters after the calibration may make the measurement inaccurate.

Suggestion: If you want to achieve an accurate measurement with new settings, recalibration is required.

8020200 (hex)

513

"The calibration cannot be completed as the measurement of all standards has not be completed."

Prompt

Additional information: This message may appear because an attempt was made to enable the error correction function before completing measurement of all calibration standards.

Suggestion: Complete measurement of all calibration standards.

8020201 (hex)

515

"Correction cannot be turned on (channel <x>, measurement of <x> does not have corresponding error correction data), please perform calibration first."

Prompt

Additional information: No corresponding error correction data for specified channel and measurement."

Suggestion: re-calibrate or recall a corresponding calibration set.

8020203 (hex)

516

"The key parameters of the current instrument state do not match the calibration set, and the correction is turned off. Key parameters include: scan type, start frequency, frequency span, and number of points."

Prompt

Additional information: None

Suggestion: Recalibrate the system or change back to the original instrument state that matches the state of the calibration set.

8020204 (hex)

517

"Because the interpolation function is disabled and the stimulus setting has changed, the correction is turned off."

Prompt

Additional information: The most accurate calibration is to use the original stimulus settings.

Suggestion: If the measurement accuracy is allowed to be reduced, the interpolation function can be enabled to allow the stimulus setting to change.

8020205 (hex)

518

"The interpolation function is turned off and the correction function is selected to restore the previous stimulus settings."

Prompt

Additional information: None

Suggestion: None

8020206 (hex)

519

"The stimulus range is beyond the original calibration setting and the correction is turned off."

Prompt

Additional information: Correction data that exceeds the stimulus settings does not exist.

Suggestion: Perform a wideband calibration by increasing the number of points and enabling the interpolation function, using the widest stimulus frequency for setting as far as possible.

8020207 (hex)

520

"Channel <x> Measurement <x> has a calibration type of 'None'; please select the calibration type via the calibration menu or by pressing the button."

Prompt

Additional information: The calibration cannot be performed because the calibration type is not selected or the calibration does not exist. This error is generated because the calibration was not found or the calibration was performed without selecting the calibration type.

Suggestion:

8020208 (hex)

521

"The calibration type does not match the selected measurement, the correction is turned off or no correction is allowed."

Prompt

Additional information: Some calibrations apply only to certain S-parameters. For example, 1-port calibration for S11 cannot be applied to 1-port calibration of S22.

Suggestion: Select a calibration type that can be used for all measurements, such as full dual port calibration.

8020209 (hex)

522

"Need to measure more standard parts."

Prompt

Additional information:

Suggestion:

802020A (hex)

524

"Hint: non-full dual two-port calibration."

Prompt

Additional information:

Suggestion:

802020C (hex)

525

"Hint: Two sets of calibration parts are used."

Prompt

Additional information:

Suggestion:

802020D (hex)

526

"No user calibration data suitable for this channel was found."

Prompt

Additional information: Calibration does not exist and cannot be corrected.

Suggestion: Select a calibration that contains the current measurement.

802020E (hex)

527

"This calibration type does not require this standard"

Prompt

Additional information: This error is generated when requesting an unspecified calibration standard during a calibration procedure.

Suggestion: Request to check the specified calibration type or cancel the measurement standard

802020F (hex)

528

"The electrical calibration system cannot be configured. Please check if the module is properly connected."

Prompt

Additional information: During the electrical calibration operation, the network analyzer must first establish normal communication with the electrical calibration module and perform module verification, otherwise the electrical calibration cannot be performed.

Suggestion: Make sure the USB cable is connected properly. Disconnect and reconnect the cable to ensure that the instrument recognizes the module.

8020210 (hex)

529

"Data out of bound: Exceeding the designed value range."

Prompt

Additional information:

Suggestion:

8020211 (hex)

530

"Execution error: Number of array dimensions not match."

Prompt

Additional information:

Suggestion:

8020212 (hex)

531

"Execution error: Array being divided by zero."

312

Prompt

Additional information:

Suggestion:

8020213 (hex)

532

"Execution error: Invalid array function."

Prompt

Additional information:

Suggestion:

8020214 (hex)

533

"Execution error: Array subscribe error."

Prompt

Additional information:

Suggestion:

8020215 (hex)

534

"Execution error: Array subscribe out of bound."

Prompt

Additional information:

Suggestion:

8020216 (hex)

535

"Execution error: Wrong matrix rank."

Prompt

Additional information:

Suggestion:

8020217 (hex)

536

"Execution error: CPU"

Prompt

Additional information:

Suggestion:

8020218 (hex)

537

"Execution error: Module cannot be deleted."

Prompt

Additional information:

Suggestion:

8020219 (hex)

538

"Execution error: Module cannot be written."

Prompt

Additional information:

Suggestion:

802021A (hex)

539

"Execution error: No input."

Prompt

Additional information:

Suggestion:

802021B (hex)

540

"Execution error: System is busy, invalid command."

Prompt

Additional information:

Suggestion:

802021C (hex)

541

"Electric calibration: The module is not in the RF path, please connect it to the designated port."

Prompt

Additional information: The RF is not connected to the electrical calibration module and no signal was found during the corresponding calibration measurement.

Suggestion: Connect the electrical calibration module to the designated port. The electrical calibration module requires a typical signal of at least -18dBm for the measurement.

802021D (hex)

542

"Execution error: No space for storing new calibrations, please delete one."

Prompt

Additional information:

Suggestion:

802021E (hex)

543

"Execution error: Insufficient space."

Prompt

Additional information:

Suggestion:

802021F (hex)

544

"Execution error: Other matrix errors."

Prompt

314

Additional information:

Suggestion:

8020220 (hex)

545

"Execution error: Unequal rank."

Prompt

Additional information:

Suggestion:

8020221 (hex)

546

"Execution error: Too few constant ranks."

Prompt

Additional information:

Suggestion:

8020222 (hex)

547

"Execution error: Too few constant ranks."

Prompt

Additional information:

Suggestion:

8020223 (hex)

548

"Perform a pre-calibration."

Prompt

Additional information:

Suggestion:

8020224 (hex)

549

"Execution error: Electrical calibration drive dynamic library error or invalid module number."

Prompt

Additional information:

Suggestion:

8020225 (hex)

550

"Execution error: Unexpected error from the electrical calibration drive."

Prompt

Additional information:

Suggestion:

8020226 (hex)

551

"Execution error: Internal drive error."

Prompt

Additional information:

Suggestion:

8020227 (hex)

552

"Hardware error: Cannot access the electrical calibration module."

Prompt

Additional information:

Suggestion:

8020228 (hex)

553

"Hardware error: Cannot release LPT port, restart."

Prompt

Additional information:

Suggestion:

8020229 (hex)

554

"Hardware error: Vector network analyzer error

Prompt

Additional information:

Suggestion:

802022A (hex)

555

"Hardware error: Failed to read enough data from the electrical calibration module."

Prompt

Additional information:

Suggestion:

802022B (hex)

556

"Operation aborted by host computer."

Prompt

Additional information:

Suggestion:

802022C (hex)

557

"Operation aborted by user."

Prompt

Additional information:

Suggestion:

802022D (hex)

558

"Memory out of bounds."

Prompt

Additional information:

Suggestion:

802022E (hex)

559

"The terminated query: message abandoned."

Prompt

Additional information:

Suggestion:

802022F (hex)

560

"Unfinished query: Incomplete program message."

Prompt

Additional information:

Suggestion:

8020230 (hex)

561

"Unfinished query: No content."

Prompt

Additional information:

Suggestion:

8020231 (hex)

562

"Queue overflow"

Prompt

Additional information:

Suggestion:

8020232 (hex)

563

"Setting conflict: Additional standards required."

Prompt

Additional information:

Suggestion:

8020233 (hex)

564

Setting conflict: Adapter calibration not possible.

Prompt

Additional information:

Suggestion:

8020234 (hex)

565

"Setting conflict: Command queue overflow."

Prompt

Additional information:

Suggestion:

8020235 (hex)

566

"Setting conflict: Calibration stopped - Analyzer settings changed."

Prompt

Additional information:

Suggestion:

8020236 (hex)

567

"Setting conflict: Calibration not done."

Prompt

Additional information:

Suggestion:

8020237 (hex)

568

"Setting conflict: Unable to find the specified GPIB board."

Prompt

Additional information:

Suggestion:

8020238 (hex)

569

"Setting conflict: unable to find/load gpib32.dll."

Prompt

Additional information:

Suggestion:

8020239 (hex)

570

"Setting conflict: unable to find/load sicl32.dll."

Prompt

Additional information:

Suggestion:

802023A (hex)

571

"Setting conflict: Unable to initialize network analyzer (wrong address?)."

Prompt

Additional information:

Suggestion:

802023B (hex)

572

"Setting conflict: Unable to load print port driver or USB driver dynamic library."

Prompt

Additional information:

Suggestion:

802023C (hex)

573

"Setting conflict: Invalid calibration sweep mode."

Prompt

Additional information:

Suggestion:

802023D (hex)

574

"Setting conflict: Invalid calibration type."

Prompt

Additional information:

Suggestion:

802023E (hex)

575

"Setting conflict: Invalid calibration."

Prompt

Additional information:

Suggestion:

802023F (hex)

576

"Setting conflict: invalid GPIB board number specified."

Prompt

Additional information:

Suggestion:

8020240 (hex)

577

"Setting conflict: invalid GPIB board type specified."

Prompt

Additional information:

Suggestion:

8020241 (hex)

578

"Setting conflict: invalid module status."

Prompt

Additional information:

Suggestion:

8020242 (hex)

579

"Setting conflict: invalid status."

Prompt

Additional information:

Suggestion:

8020243 (hex)

580

"Setting conflict: LPT port must be 1~4."

Prompt

Additional information:

Suggestion:

8020244 (hex)

581

"Unable to configure the electrical calibration system, check that the module is properly connected."

Prompt

Additional information:

Suggestion:

8020245 (hex)

582

"Setting conflict: specified LPT port does not exist."

Prompt

Additional information:

Suggestion:

8020246 (hex)

583

"Setting conflicts: please use the frequency domain for calibration."

Prompt

Additional information:

Suggestion:

8020247 (hex)

584

"Setting conflicts: Please use the frequency domain for calibration."

Prompt

320

Additional information:

Suggestion:

8020248 (hex)

585

"Setting conflict: analyzer address must be 0~30."

Prompt

Additional information:

Suggestion:

8020249 (hex)

586

"Setting conflicts: wrong print port driver or USB driver dynamic library."

Prompt

Additional information:

Suggestion:

802024A (hex)

587

"Syntax error: ECAL:DELAY command must have two numbers."

Prompt

Additional information:

Suggestion:

802024B (hex)

588

"Syntax error: incorrect syntax."

Prompt

Additional information:

Suggestion:

802024C (hex)

589

"Syntax error: unknown command."

Prompt

Additional information:

Suggestion:

802024D (hex)

590

"The module port on the RF path is incorrect."

Prompt

Additional information: None

Suggestion: None

802024E (hex)

591

"Not the module described by the user."

Prompt

Additional information: None

Suggestion: None

802024F (hex)

592

"The source power calibration data corresponding to current measurement channel and source port is not found."

Prompt

Additional information: An attempt was made to turn on source power calibration but no calibration data.

Suggestion: Perform a source power calibration.

8020250 (hex)

593

"The source power calibration scan cannot be performed. The channel and source port corresponding to the current measurement cannot be corrected."

Prompt

Additional information: An attempt was made to turn on source power calibration but no complete calibration data.

Suggestion: perform a complete source power calibration.

8020251 (hex)

594

"Failed to open GPIB, please check if the GPIB card and driver are installed correctly."

Prompt

Additional information:

Suggestion:

8020252 (hex)

595

"The effective power meter has not been found. Please restart the power meter with GPIB."

Prompt

Additional information:

Suggestion:

8020253 (hex)

596

"With calibration turned on, the calibration power of the source power calibration in channel %2 of port %1 has changed. The calibration will not be turned off, but the power value may no longer characterize the calibration."

Prompt

Additional information: Source power calibration accuracy may be in fault.

Suggestion: If you need high precision measurements, re-execute the source power calibration.

8020254 (hex)

597

"This software version does not support the electrical calibration function at present."

Prompt

Additional information:

Suggestion:

8020255 (hex)

598

"When measuring the sliding load standard, improper sliding will not correctly fit a circle. The standard raw impedance is used to determine the directionality of one or more points."

Prompt

Additional information: To accurately describe the standard, the sliding load must be properly slid to ensure adequate sampling along the complex circle or Smith chart. Undersampling may cause inaccurate results.

Suggestion: When using a sliding load, for better results, be sure to use a multiple of the sliding position that covers the entire sliding range.

8020256 (hex)

599

"This feature requires an unused channel but cannot be found. Please release a channel and try again."

Prompt

Additional information:

Suggestion: You must delete at least one channel that is currently in use.

8020257 (hex)

600

"The original calibration cannot be interpolated in the segment scan mode. Calibration is off."

Prompt

Additional information: None

Suggestion: None

8020258 (hex)

601

"Unable to complete calibration (standard measurement not completed)"

Error

Additional information:

Suggestion:

8020259 (hex)

602

Correction not turned on."

Error

Additional information:

Suggestion:

802025A (hex)

603

"Power correction cannot be turned on. Please perform power meter calibration first."

Error

Additional information:

Suggestion:

802025B (hex)

604

"The scan status changes, the power correction data is invalid, and the power correction is turned off."

Error

Additional information:

Suggestion:

802025C (hex)

605

"The power correction is turned on and the sweep restores the original state."

Error

Additional information:

Suggestion:

802025D (hex)

606

"Calibration in progress, no operation allowed."

Prompt

Additional information:

Suggestion:

802025E (hex)

607

"Port error!"

Prompt

Additional information:

Suggestion:

802025F (hex)

608

"Calibration type not set."

Error

Additional information: The calibration can only be performed if the calibration is present or the correct calibration type is selected.

Suggestion: This error may occur when no calibration was found. In this case, you can select a calibration that meets the current measurement. This error can also occur if the calibration type is not selected and calibration is started.

8020260 (hex)

609

"Calibration feature cannot be achieved."

Error

Additional information: The specified calibration may be one of several options, for example: Response calibration requires a single standard, 1-port calibration requires 3 standards, and full 2-port calibration requires 12 standards.

Suggestion: Be sure to measure only the standards required in the specified calibration type.

8020261 (hex)

610

"The calibration class is not valid for the current calibration type. Please choose a different calibration class or a different calibration type."

Error

Additional information: None

Suggestion: None

8020262 (hex)

611

"No calibration standard data corresponding to the selected calibration type was found."

Error

Additional information: Raw measurement data for the specified standard was not found in the current measurement buffer.

Suggestion: Make sure that the selected standard is required for the current calibration type, and that some calibration types do not require all standards.

8020263 (hex)

612

"No error item data corresponding to the selected calibration type was found."

Error

Additional information: No specified error term in the error correction buffer (this buffer contains all the error coefficients of the current calibration).

Suggestion: Make sure that the selected standard is required for the current calibration type, and that some calibration types do not contain all error items.

8020264 (hex)

613

"Reserved"

Error

Additional information: Access to the calibration set was unsuccessful and the calibration set may have been deleted or corrupted.

Suggestion: Retry or select another calibration set. If the unsuccessful calibration set is still in the calibration set list, it should be removed.

8020265 (hex)

614

"The specified measurement is not compatible with the current calibration. Please select a different measurement, or load another different calibration type, or recalibrate."

Error

Additional information: Block measurement selection so that measurement calibration is not turned off. Not all measurements are supported for each calibration type, for example: S11 1-PORT calibration cannot be used to calibrate S12 measurements. When a measurement that is not supported by the current calibration is selected, a message is displayed and the calibration is turned off.

Suggestion: Full 2-port calibration is compatible with all S-parameters.

8020266 (hex)

615

"New calibration set created."

Error

Additional information: The newly created calibration set will be automatically named and time stamped. The calibration set will only be saved if the calibration process is completed; if the calibration is aborted or not completed, the calibration set will be deleted.

Suggestion: Prompt

8020267 (hex)

616

"Port extension is not available in waveguide mode!"

Prompt

Additional information:

Suggestion: None

8020268 (hex)

617

"Pre-tuning calibration failed"

Error

Additional information:

Suggestion: None

8020269 (hex)

618

"The current frequency setting is not within the effective frequency (<x>) range of the electrical calibration component. Please reset the frequency and try again."

Prompt

Additional information:

Suggestion: None

802026A (hex)

619

"Electric calibration interrupted by user."

Prompt

Additional information:

Suggestion: None

802026B (hex)

620

"Measuring status changes, turn off the antenna, RCS calibration."

Error

Additional information:

Suggestion: None

802026C (hex)

621

"Measuring status changes, unable to turn on the antenna, RCS calibration."

Error

Additional information:

Suggestion: None

802026D (hex)

622

"Invalid calibration data, unable to turn on the antenna, RCS calibration."

Error

Additional information:

Suggestion: None

802026E (hex)

623

"The number of measurement steps should be 1 - 40!"

Warning

Additional information:

Suggestion: None

802026F (hex)

624

"The number of measurement steps is out of range!"

Warning

Additional information:

Suggestion: None

8020270 (hex)

625

"The port number is out of range!"

Warning

Additional information:

Suggestion: None

8020271 (hex)

626

"No connector has been specified for the port!"

Warning

Additional information:

Suggestion: None

8020272 (hex)

627

"No such calibration kit!"

Warning

Additional information:

Suggestion: None

8020273 (hex)

628

"The connector does not have this calibration piece. Please re-select the correct calibration kit under the connector"

Warning

Additional information:

Suggestion: None

8020274 (hex)

629

"No connector of this type!"

Warning

Additional information:

Suggestion: None

8020275 (hex)

630

"Calibration settings not completed!"

Warning

Additional information:

Suggestion: None

8020276 (hex)

631

"Calibration information incorrect!"

Warning

Additional information:

Suggestion: None

8020277 (hex)

632

"Saving calibration information incorrectly!"

Warning

Additional information:

Suggestion: None

8020278 (hex)

633

"Through pass setting information incorrect!"

Warning

Additional information:

Suggestion: None

8020279 (hex)

634

"Calibration set file: <x> loading failed."

Error

Additional information: The calibration kit file is a collection of calibration kits stored on the hard disk.

Suggestion: Restart the network analyzer. If the error persists, you should delete the calibration set file and restart the network analyzer program (the calibration set file is stored in the network analyzer program installation directory).

802027A (hex)

635

"Calibration set file: <x> not saved."

Error

Additional information: File operation incorrect, saving operation aborted.

Suggestion: Retry.

802027B (hex)

636

"A calibration kit deleted."

Prompt

Additional information: A calibration set was successfully deleted, which may be the result of a user application or intentional operation.

Suggestion: None

802027C (hex)

637

"Calibration kit file version: <x> is not compatible with the current measurement."

Error

Additional information: Version mismatch makes the calibration kit unavailable, which may be due to instrument software upgrades.

Suggestion: If the version does not match due to a software upgrade, you can only reinstall the old version of the software or recreate the calibration kit under the current version.

802027D (hex)

638

"Incompatible calibration set found: <x> of <y> stored calibration set was loaded."

Error

Additional information: Some calibration sets in the calibration set file have errors.

Suggestion: Check the calibration set file with the calibration set and delete conflicting files.

802027E (hex)

639

"Calibration set file: <x> not found, a new file will be created."

Prompt

Additional information: The calibration set file is stored on the hard disk. When the network analyzer program is started, it will search for the existence of the file. If it exists, it will be loaded. Otherwise, a new file will be created and the information will be prompted.

Suggestion: None

802027F (hex)

640

"Specified calibration set is in use."

Error

Additional information: It indicates that multiple calibration set users are attempting to perform calibration and cause conflicts.

Suggestion: Save the instrument state, reset the network analyzer and call back the instrument status. This can terminate any processing in progress.

8020280 (hex)

641

"Unable to open specified calibration set."

Error

Additional information: Multiple users may be attempting to access this calibration set.

Suggestion: Disable other users and make sure that only one user is accessing it.

8020281 (hex)

642

"Achieving the maximum register number of the calibration set. Delete old or useless calibration sets before attempting to create a new calibration set."

Error

Additional information: The network analyzer can set up to 100 calibration sets.

Suggestion: Delete the calibration set or calibration set file.

8020282 (hex)

643

"Incorrect calibration procedure!"

Warning

Additional information:

Suggestion: None

8020283 (hex)

644

"A valid calibration must be performed before the error correction is turned on."

Error

Additional information: This usually indicates that the calibration process has not been completed or that there is no calibration that matches the selected measurement in the currently selected calibration set.

Suggestion: Find a calibration set that matches the current measurement. This type of error can also occur when you are trying to perform a calibration without selecting a calibration type. Specify the calibration type before starting the calibration process.

8020284 (hex)

645

"Not completed all measurements!"

Warning

Additional information:

Suggestion: None

8020285 (hex)

646

"Calibration set not loaded, version too new."

Error

Additional information: An older version of the software attempts to use the new calibration file, the version is not compatible.

Suggestion: This calibration set can be deleted. The calibration set is stored in SNACalSets.dat in the network analyzer installation directory. You can delete the file and restart the network analyzer software.

8020286 (hex)

647

"No port polarity information for this port!"

Warning

Additional information:

Suggestion: None

8020287 (hex)

648

"2-port used. Switch to 4-port!"

Tip

Additional information:

Suggestion: None

8020288 (hex)

649

"Command invalid for 4-port!"

Prompt

Additional information:

Suggestion: None

8020289 (hex)

650

"This command only supports 2-port!"

Prompt

Additional information:

Suggestion: None

802028A (hex)

651

"Please select a valid calibration kit!"

Prompt

Additional information:

Suggestion: None

802028B (hex)

652

"The selected calibration piece cannot cover the current frequency range!"

Prompt

Additional information:

Suggestion: None

802028C (hex)

653

"The second port cannot use this command!"

Prompt

Additional information:

Suggestion: None

802028D (hex)

654

"The topology type is inconsistent!"

Prompt

Additional information:

Suggestion: None

802028E (hex)

655

"No measurement parameters selected!"

Prompt

Additional information:

Suggestion: None

802028F (hex)

656

"Balance parameter switch not turned on!"

Prompt

Additional information:

Suggestion: None

8020290 (hex)

657

"Wrong topology type!"

Prompt

Additional information:

Suggestion: None

8020291 (hex)

658

"Invalid port input!"

Prompt

Additional information:

Suggestion: None

8020292 (hex)

659

"The current calibration standard does not match the value entered!"

Prompt

Additional information:

Suggestion: None

8020293 (hex)

772

"The DSP board driver can not work properly, please check the hardware. The software will use the simulated data!"

Error

Additional information: The network analyzer is unable to communicate with the DSP board. Possible fault in the hardware or driver.

Suggestion:

8030304 (hex)

773

"The serial bus of the instrument cannot work properly."

Error

Additional information: The serial EEPROM of the instrument may all be '1' or all be '0', which may be caused by a problem of the serial bus hardware.

Suggestion:

8030305 (hex)

774

"IF overload."

Error

Additional information:

Suggestion:

8030306 (hex)

848

"Losing lock<x>."

Error

Additional information: The source cannot properly lock the phase. This may be caused by hardware failure, poor calibration, or damaged data in the serial EEPROM.

Suggestion: Perform source calibration. Click on System / Adjustment / Source Calibration.

8030350 (hex)

849

"Phase locking failed <x>."

Error

Additional information: None

Suggestion: None

8030351 (hex)

850

"Unknown hardware error."

Error

Additional information: A hardware failure prevented communication with the DSP.

Suggestion:

8030352 (hex)

851

"DSP read-write error."

Error

Additional information:

Suggestion:

8030353 (hex)

855

"Source unlevelled."

Error

Additional information: The source cannot be properly leveled to the required power. It indicates that the power is not accurate.

Suggestion: Test a different power level and recalibrate the source if the the problem persists.

8030357 (hex)

856

"Local oscillator unlevelled."

Error

Additional information: None.

Suggestion: None.

8030358 (hex)

859

"YIG calibration failure."

Error

Additional information: Internal self-calibration tuning of the YIG oscillator failed.

Suggestion:

803035B (hex)

861

"Simulated slope calibration failed."

Error

Additional information: Internal simulated slope calibration failed.

Suggestion:

803035D (hex)

865

"EEPROM write failure."

Error

Additional information: An attempt to store calibration data to the EEPROM failed. It could be caused by a hardware failure.

Suggestion:

8030361 (hex)

867

"An attempt was made to write an input or read-only I/O port."

334

Error

Additional information: An attempt was made to write to an input or read-only I/O port.

Suggestion: Set the data port to output/write mode before writing a port.

8030363 (hex)

868

"An attempt was made to read the write-only I/O port."

Error

Additional information: An attempt was made to read an output or write-only I/O port.

Suggestion: Set the data port to input/read mode first before reading a port.

8030364 (hex)

1025

"The instrument does not shut down properly. The program is in an unstable state and needs to be restarted."

Error

Additional information: This message is displayed when the vector network program crashes. If this message persists, please consult the Service Center.

Suggestion:

8040401 (hex)

1026

"Incorrect limit segment type."

Error

Additional information: There are three types of limit segments: OFF, MAX and MIN.

Suggestion:

8040402 (hex)

1027

"Group delay format cannot be used in point frequency or power sweep mode"

Warning

Additional information: In the single frequency point scan mode, the group delay format cannot be used, otherwise invalid data will be generated.

Suggestion: Ignore the data or choose another format or scan method.

8040403 (hex)

1028

"Limit line test failed."

Prompt

Additional information: The limit line test failed.

Suggestion:

8040404 (hex)

1029

"Limit line test successful."

Prompt

Additional information: Limit line test is successful.

Suggestion:

8040405 (hex)

1030

"Exceeding the maximum number of tests allowed."

Warning

Additional information: You can only create up to 512 measurements.

Suggestion: None

8040406 (hex)

1031

"Internal error in the analyzer. An error occurred while adding a new measurement."

Error

Warning

Additional information: If this message persists, please consult the Service Center.

8040407 (hex)

1032

"No measurement was found for the selected operation. The operation could not be performed."

Warning

Additional information: None

Suggestion: create a measurement before performing this operation.

8040408 (hex)

1033

"You cannot create two measurements with the same name"

Warning

Additional information: None

Suggestion:

8040409 (hex)

1034

"The selected trace has not stored a storage trace. Please save a storage trace before tracing."

Warning

Additional information: Before performing the tracing calculation, you must have saved a storage trace.

Suggestion:

804040A (hex)

1035

"Sweep averaging done."

Prompt

Additional information: COM programming information. The sweep averaging is done, achieving the set average factor.

Suggestion:

804040B (hex)

1036

"Reset sweep averaging done."

Error

Additional information: COM programming information. The sweep averaging is not completed, the set average factor is not achieved.

Suggestion:

804040C (hex)

1037

"Time domain conversion and gate operation require at least 3 points, or they will be canceled."

Prompt

Additional information: None

Suggestion: Increase the number of sweep points.

804040D (hex)

1038

"Step type can only be used when the time domain measurement type is low pass; bandpass can only be used when the stimulus type is pulsed."

Prompt

Additional information: None

Suggestion: Step type can only be used when the time domain measurement type is low pass.

804040E (hex)

1039

"Too few points to perform smoothing."

Warning

Additional information:

Suggestion:

804040F (hex)

1040

"Too many time-domain low-pass points, exceeding the frequency range, automatically switched to band-pass mode by the system"

Warning

Additional information:

Suggestion:

8040410 (hex)

1041

"Current configuration cannot set the low pass frequency."

Warning

Additional information:

Suggestion:

8040411 (hex)

1042

"Current sweep settings cannot complete time domain low pass, automatically switched to time domain band pass."

Warning

Additional information:

Suggestion:

8040412 (hex)

1043

"Switched to time domain low pass, corresponding frequency settings changed."

Warning

Additional information:

Suggestion:

8040413 (hex)

1044

"The sweep settings have changed and cannot meet the requirements for time domain low pass, automatically switched to time domain band pass."

Warning

Additional information:

Suggestion:

8040414 (hex)

1045

"Specified measurement not displayed."

Prompt

Additional information:

Suggestion:

8040415 (hex)

1103

"Repeated measurement name."

Prompt

Additional information:

Suggestion:

804044F (hex)

1104

"Exceeding the limit for measurement number."

Error

Additional information: You can only create up to 512 measurements.

Suggestion:

8040450 (hex)

1105

"Invalid parameter."

Error

Additional information: The measurement parameters entered during programming are invalid.

Suggestion:

8040451 (hex)

1106

"No measurement found."

Error

Additional information:

Suggestion:

8040452 (hex)

1107

"No storage trace, unable to operate"

Error

Additional information: The trace needs to be stored before trace operation.

Suggestion: Save a storage trace

8040453 (hex)

1108

"No reference marker."

Error

Additional information: An attempt was made to create a Δ marker function (for COM only) before creating a reference marker

Suggestion:

8040454 (hex)

1109

"Data and storage trace not match, trace operation turned off."

Error

Additional information: Warning - The channel settings were changed while performing the trace operation.

Suggestion: Save a storage trace before opening the storage trace.

8040455 (hex)

1110

"Data and storage trace not match. For trace operations, memory and data traces should have similar measurement conditions."

Error

Additional information: An attempt was made to perform a trace operation on unmatched data and storage traces.

Suggestion: Save a storage trace first

8040456 (hex)

1111

"Marker bandwidth not found."

Error

Additional information: The portion of the trace that meets the specified bandwidth criteria cannot be found.

Suggestion:

8040457 (hex)

1112

"Peak value not found."

Error

Additional information: The portion of the trace that meets the specified peak value standard cannot be found.

Suggestion: See marker peak standard.

8040458 (hex)

1113

"Target search value not found."

Error

Additional information: No interpolated data points matching the search value were found.

Suggestion:

8040459 (hex)

1114

"Reflex measurements (such as S11) must provide an auxiliary port to clearly identify 2-port measurements on a multi-port instrument."

Error

Additional information:

Suggestion:

804045A (hex)

1115

"Receiver power calibration disabled and turned off due to measurement type or source port changes."

Warning

Additional information:

Suggestion:

804045B (hex)

1116

"Receiver power calibration requires activation of non-ratio power measurements."

Warning

Additional information:

Suggestion:

804045C (hex)

1117

"The current active measurement does not have a suitable source power calibration that matches the channel and source port. Before performing receiver power calibration, source power calibration or callback-one source power calibration should be done."

Warning

Additional information:

Suggestion:

804045D (hex)

1118

"Attempted operation only suitable for standard measurement types."

Error

Additional information:

Suggestion:

804045E (hex)

1119

"Custom measurements cannot be loaded because they do not match the network analyzer hardware."

Error

Additional information:

Suggestion:

804045F (hex)

1120

"Custom measurements cannot be loaded because they do not match the network analyzer software."

Error

Additional information:

Suggestion:

8040460 (hex)

1121

"Custom measurement load failed for unknown reasons."

Error

Additional information:

Suggestion:

8040461 (hex)

1122

"Custom measurement data processing generates an exception and will be terminated. The network analyzer software may be in an unstable state. It is recommended to close the program and re-run."

Error

Additional information:

Suggestion:

8040462 (hex)

1123

"Attempted operation only suitable for custom measurement types."

Error

Additional information:

Suggestion:

8040463 (hex)

1124

"Requested custom measurement not available."

Error

Additional information:

Suggestion:

8040464 (hex)

1125

"Requested custom algorithm does not exist."

Error

Additional information:

Suggestion:

8040465 (hex)

1126

"Normalization cannot be performed because the measurement does not have a valid divisor memory area."

Error

Additional information:

Suggestion:

8040466 (hex)

1127

"Unable to provide raw data required for the measurement."

Warning

Additional information:

Suggestion:

8040467 (hex)

1128

"Selected sweep type does not allow time domain conversion or gate addition, time domain conversion or gate addition prohibited."

Prompt

Additional information:

Suggestion:

8040468 (hex)

1284

"Status word of instrument changed."

Prompt

Additional information:

Suggestion:

8050504 (hex)

1285

"Error code caused by received SCPI command is <x>: "<x>"."

Prompt

Additional information:

Suggestion:

8050505 (hex)

1400

342

"<X> command error."

Warning

Additional information:

Suggestion:

8050578 (hex)

1401

"Command parameters must be entered for <x> ."

Warning

Additional information:

Suggestion:

8050579 (hex)

1402

"Incorrect command parameters entered for <x> ."

Warning

Additional information:

Suggestion:

805057A (hex)

1403

"<x> command cannot be queried."

Error

Additional information:

Suggestion:

805057B (hex)

1405

"Too few parameters following <x> command."

Error

Additional information:

Suggestion:

805057D (hex)

1406

"Too many parameters following <x> command."

Error

Additional information:

Suggestion:

805057E (hex)

1407

"Incorrect parameter type entered for <x>."

Error

Additional information:

Suggestion:

805057F (hex)

1408

"Incorrect parameter unit for <x>."

Error

Additional information:

Suggestion:

8050580 (hex)

1409

"Parameter unit for <x> not matching."

Error

Additional information:

Suggestion:

8050581 (hex)

1411

"Incorrect input of <x> string parameter."

Error

Additional information:

Suggestion:

8050583 (hex)

1412

"Incorrect input of <x> integer parameter."

Error

Additional information:

Suggestion:

8050584 (hex)

1413

"Incorrect input of <x> floating-point parameter."

Error

Additional information:

Suggestion:

8050585 (hex)

1414

"Incorrect input of <x> char parameter."

Error

Additional information:

Suggestion:

8050586 (hex)

1415

"<x> parameter cannot be used with units."

Error

Additional information:

Suggestion:

8050587 (hex)

1416

"More than 50 characters used in <x> string."

Error

Additional information:

Suggestion:

8050588 (hex)

1419

"<x> command must be queried."

Error

Additional information:

Suggestion:

805058B (hex)

1420

"Actual number of characters entered for <x> not meeting the requirement."

Error

Additional information:

Suggestion:

805058C (hex)

1421

"Incorrect ASCII code entered."

Error

Additional information:

Suggestion:

805058D (hex)

1422

"Incorrect input of scientific notation for <x>."

Error

Additional information:

Suggestion:

80505E (hex)

1425

"Memory allocation failed."

Error

Additional information:

Suggestion:

8050591 (hex)

1427

"MIN or MAX parameter input error."

Error

Additional information:

Suggestion:

8050593 (hex)

1535

"Command obtained by parsing: <x>."

Prompt

Additional information:

Suggestion:

80505FF (hex)

1536

"Each window supports up to 8 traces, and trace <x> cannot be built in window <x>."

Warning

Additional information: None

Suggestion: Create a trace in another window.

8060600 (hex)

1537

"With more than 32 data windows created, you cannot create any new window."

Warning

Additional information: None

Suggestion: Create a trace in an existing window.

8060601 (hex)

1538

"Data window does not exist, measurement cannot be completed."

Warning

Additional information: Programmable SCPI operation attempts to create new measurements with no window displayed.

Suggestion: Create a new window before creating a measurement. See the example of creating a measurement using SCPI.

8060602 (hex)

1539

"No data trace in the selected window, operation cannot be completed."

Warning

Additional information: None

Suggestion: None

8060603 (hex)

1540

"Exceeding the limit of up to <x> traces per window, impossible to arrange existing measurements in <x> windows."

Warning

Additional information: The upper limit of up to 8 traces per window has been exceeded, you cannot place existing measurements into the specified window. See arranging the measurement help that exists.

Create more windows or delete some traces.

8060604 (hex)

1541

"Unable to establish connection with specified printer."

Warning

Additional information: None

Suggestion: Refer to printer Help.

8060605 (hex)

1542

"Cancel the printout."

Prompt

Additional information: None

Suggestion: None

8060606 (hex)

1615

"No enough storage space to create a new window."

Error

Additional information:

Suggestion:

8060649 (hex)

1616

"No window found."

Error

Additional information: Specified window in the program does not exist.

Suggestion: Query the window name before specifying it.

8060650 (hex)

1617

"Copy the ID of the specified window."

Error

Additional information: None

Suggestion: None

8060651 (hex)

1618

"Exceeding the limit of 32 windows to be displayed, no new windows can be created."

Error

Additional information: Up to 32 windows per screen.

Suggestion: None

8060652 (hex)

1619

"Exceeding the limit of up to 8 traces to be displayed in one window, trace <x> cannot be created."

Error

Additional information: Up to 8 traces per window. Refer to related help documents for traces channels, and windows.

Suggestion: Create a trace in another window.

8060653 (hex)

1620

"No trace found."

Error

Additional information: The program attempts to communicate with a trace that does not exist.

Suggestion: Please query the ID of the trace before writing.

8060654 (hex)

1621

"Operating system cannot recognize the printer."

Error

Warning

Suggestion:

8060655 (hex)

1622

"No active trace."

Error

Warning

Suggestion:

8070656 (hex)

1623

"Trace already exists."

Error

Warning

Suggestion:

8070657 (hex)

1624

"Start or stop value cannot be set in the 'full bandwidth' status."

Error

Warning

Suggestion:

8070658 (hex)

1625

"Specified marker does not exist."

Error

Warning

Suggestion:

8070659 (hex)

1626

"Specified window already exists."

Prompt

Warning

Suggestion:

807065A (hex)

1792

"Sweep completed."

Prompt

Additional information: None

Suggestion: None

8070700 (hex)

1793

"All trigger requests completed."

Prompt

Additional information:

Suggestion:

8070701 (hex)

1794

"Sweep interrupted by the last trigger."

Prompt

Additional information:

Suggestion:

8070702 (hex)

1795

"To use the segment sweep method, you must ensure that there is at least one active segment with more than 0 sweep points in the segment list."

Prompt

Additional information: An attempt was made to change the sweeping mode to segment sweeping mode, but there is no defined segment or there is no sweeping point in the defined segment.

Suggestion: Set at least one active segment and ensure that there is at least one sweep point in the active segment.

8070703 (hex)

1796

"Setting channel spam."

Prompt

Additional information: This message appears because the channel settings have changed, but the data is still obtained according to the previous channel settings. The message Clear Channel Spam will be generated when the data is set according to the new channel settings.

Suggestion: None

8070704 (hex)

1797

"Clear channel spam"

Prompt

Additional information: The previous setting message occurred when the channel settings have changed but the channel still has data obtained with the original channel settings. This clear message will occur when new channel data is obtained.

Suggestion: None

8070705 (hex)

1798

"An error occurred when deleting the segment."

Prompt

Additional information:

Suggestion: None

8070706 (hex)

1799

"Frequency range exceeds limit, frequency offset function automatically turned off."

Prompt

Additional information:

Suggestion:

8070707 (hex)

1800

"Limit for sweep points exceeded, operation failed."

Error

Additional information:

Suggestion:

8070708 (hex)

1801

"Current pulse setting causes a narrowband pulse calculation error."

Error

Additional information:

Suggestion:

8070709 (hex)

1802

"Current pulse settings may not be able to make the correct broadband measurements."

Error

Additional information:

Suggestion:

807070A (hex)

1803

"Pulse width cannot be greater than 90% of PRI!"

Error

Additional information:

Suggestion:

807070B (hex)

1869

"Current frequency setting not suitable for logarithmic sweep, automatically switched to linear sweep."

Error

Additional information:

Suggestion:

807074D (hex)

1870

"No measurement selected."

Error

Additional information: No measurement is selected.

Suggestion:

807074E (hex)

1871

"Channel number out of range!"

Error

Additional information: The specified channel number exceeds the allowable range!

Suggestion:

807074F (hex)

1872

"No channel found."

Error

Additional information: A channel that does not exist is specified under program control.

Suggestion: Query the channel number and refer to the query results.

8070750 (hex)

1873

"Requested sweep segment not found."

Error

Additional information: A sweep segment that does not exist is specified under program control.

Suggestion:

8070751 (hex)

1874

"Sweep segment list is empty."

Error

Additional information: At least one segment should be defined in the segment table sweep mode. This error only occurs during remote control.

Suggestion:

8070752 (hex)

1875

"The number of sweep points for an active sweep segment list is 0."

Error

Additional information: In the segment list sweep mode, you must ensure that there is at least one segment with data points. This error only occurs during remote control.

Suggestion:

8070753 (hex)

1876

"Invalid source attenuation specified."

Error

Additional information: An attempt was made to set the channel attenuation characteristic in a vector network without a source attenuator.

Suggestion:

8070754 (hex)

1877

"Too many sweep points, unable to use logarithmic sweep mode. Please reduce the number of sweep points."

Error

Additional information: For logarithmic sweep, the maximum number of sweep points that can be used is 401.

Suggestion:

8070755 (hex)

1878

"Number of points set greater than the number that can be selected for logarithmic sweep mode."

Error

Additional information: For logarithmic sweep, the maximum number of sweep points that can be used is 401.

Suggestion:

8070756 (hex)

2048

"This feature can be used only after adding options on the basis of a standard analyzer."

Error

Additional information: None

Suggestion: To view the options on the analyzer, click on Help\About Network Analyzer. See the analyzer options for more information.

8080800 (hex)

2049

"Current measuring instrument does not have the features you need."

Error

Additional information: None

Suggestion: None

8080801 (hex)

2050

"The feature you need conflicts with the current state of the instrument."

Error

Additional information: None

Suggestion: None

8080802 (hex)

2051

"File <x> saved."

Prompt

Additional information: None

Suggestion: None

8080803 (hex)

2052

"File <x> not saved."

Error

Additional information: None

Suggestion: If you are using a floppy disk for storage, check that the floppy disk is inserted in the drive and is not full. Check if the file name meets the naming rules.

8080804 (hex)

2053

"An attempt to open the file failed, file <x> not found."

Error

Additional information: None

Suggestion: None

8080805 (hex)

2054

"<X> header error."

Error

Additional information: None

Suggestion: Re-copy or delete this file.

8080806 (hex)

2055

"Invalid status file, cannot be loaded!"

Error

Additional information: None

Suggestion: .

8080807 (hex)

2056

"Request to enter sleep mode."

Error

Additional information: None

Suggestion: None

8080808 (hex)

2057

"Wake up from sleep mode. the program received a PBT_APMRESUMEAUTOMATIC message."

Error

Additional information: None

Suggestion: None

8080809 (hex)

2058

"Wake up from standby mode. the program received a PBT_APMRESUMESUSPEND message."

Error

Additional information: None

Suggestion: None

808080A (hex)

2059

"Wake up from standby mode. the program received a PBT_APMRESUMECRITICAL message."

Warning

Additional information: None

Suggestion: None

808080B (hex)

2060

"Wake up from unknown sleep mode. The program received a NO PBT_Message message upon allocation and attempt to recover."

Warning

Additional information: None

Suggestion: None

808080C (hex)

2061

"File <x> already exists. Overwriting file."

Error

Additional information: Only used in remote applications.

Suggestion: None

808080D (hex)

2062

"No valid reset state, unable to reset user."

Error

Additional information:

Suggestion: None

808080E (hex)

2063

"File <x> recovered."

Error

Additional information: Only used in remote applications.

Suggestion: None

808080F (hex)

2064

"<x> version lower than current version."

Error

Additional information: You are trying to recover a file that is no longer valid.

Suggestion: You must manually recreate the file.

8080810 (hex)

2065

"<x> version newer than latest version."

Error

Additional information: An attempt was made to recover the latest version of a file generated by a network analyzer software.

Suggestion: You must manually recreate the file.

8080811 (hex)

2066

"An error occurred while reading file <x>."

Error

Additional information: This file may be damaged.

Suggestion: You must recreate the file.

8080812 (hex)

2067

"Window kernel error: <x>"

Error

Additional information: None

Suggestion: None

8080813 (hex)

2068

"<x>GPIB: unable to set and clear REN."

Error

Additional information: None

Suggestion: None

8080814 (hex)

2069

"Converting GPIB mode to system controller mode."

Prompt

Additional information: None

Suggestion: None

8080815 (hex)

2070

"Converting GPIB mode to listen-speak mode."

Prompt

Additional information: None

Suggestion: None

8080816 (hex)

2071

"The network analyzer can only be set to GPIB system controller mode when the GPIB status is local. Stop any remote network analyzer program and press the Macro/Local button to try again." "

Prompt

Additional information: Refer to LCL and RMT operations

Suggestion: Press the Macro/Local button to try again.

8080817 (hex)

2072

"Range setting error."

Error

Additional information:

Suggestion:

8080818 (hex)

2073

"Configuration changed, please sweep again."

Error

Additional information:

Suggestion:

8080819 (hex)

2074

"GPIB cannot be a system controller."

Error

Additional information:

Suggestion:

808081A (hex)

2075

"GPIB cannot clear IFC."

Error

Additional information:

Suggestion:

808081B (hex)

2076

"GPIB cannot write."

Error

Additional information:

Suggestion:

808081C (hex)

2077

"GPIB cannot call callbacks."

Error

Additional information:

Suggestion:

808081D (hex)

2078

"EDVR: System error."

Error

Additional information:

Suggestion:

808081E (hex)

2079

"ECIC: function requires GPIB interface to be in CIC mode."

Error

Additional information:

Suggestion:

808081F (hex)

2080

"ENOL: GPIB has no listeners."

Error

Additional information:

Suggestion:

8080820 (hex)

2081

"EADR: incorrect addressing of GPIB interface."

Error

Additional information:

Suggestion:

8080821 (hex)

2082

"EARG: parameter invalid for this function."

Error

Additional information:

Suggestion:

8080822 (hex)

2083

"ESAC: not the GPIB interfaced of required system controller."

Error

Additional information:

Suggestion:

8080823 (hex)

2084

"EABO: I/O operation canceled (timeout)."

Error

Additional information:

Suggestion:

8080824 (hex)

2085

"ENEB: GPIB interface that does not exist."

Error

Additional information:

Suggestion:

8080825 (hex)

2086

"EDMA: DMA error."

Error

Additional information:

Suggestion:

8080826 (hex)

2087

"EOIP: Executing asynchronous I/O operation."

Error

Additional information:

Suggestion:

8080827 (hex)

2088

"ECAP: Unable to operate."

Error

Additional information:

Suggestion:

8080828 (hex)

2089

"EFSO: File system error."

Error

Additional information:

Suggestion:

8080829 (hex)

2090

"EBUS: GPIB bus error."

Error

Additional information:

Suggestion:

808082A (hex)

2091

"ESTB: Serial polling status byte queue overflow."

Error

Additional information:

Suggestion:

808082B (hex)

2092

"ESRQ: query request signal blocked."

Error

Additional information:

Suggestion:

808082C (hex)

2093

"ETAB: table error."

Error

Additional information:

Suggestion:

808082D (hex)

2094

GPIB reading error."

Error

Additional information:

Suggestion:

808082E (hex)

2095

"Query interrupted."

Warning

Additional information: None

Suggestion:

808082F (hex)

2096

"Exceeding the limit of up to 2000 instructions to be recorded, remaining operations cannot be recorded."

Prompt

Additional information: None

Suggestion:

8080830 (hex)

2097

"Test device control error, please check GPIB connection."

Error

Additional information: None

Suggestion:

8080831 (hex)

2098

"VISA library loading failed. Please reinstall VISA driver."

Error

Additional information: None

Suggestion:

8080832 (hex)

2099

"External source initialization failed."

Error

Additional information: None

Suggestion:

8080833 (hex)

2100

"Frequency setting out of normal frequency range, setting invalid."

Error

Additional information: None

Suggestion:

8080834 (hex)

2120

"COM bound later can't call this method."

Error

Additional information: None

Suggestion: Call alternatives described in the COM Programming Manual.

8080878 (hex)

2123

"Bit weight number out of bound."

Error

Additional information: None

Suggestion: None

808084B (hex)

2124

"File extension inconsistent."

Error

Additional information: None

Suggestion: None

808084C (hex)

2125

"File already exists."

Error

Additional information: None

Suggestion: None

808084D (hex)

2126

"File missing an extension."

Error

Additional information: None

Suggestion: None

808084E (hex)

2127

"Folder or file does not exist."

Error

Additional information: None

Suggestion: None

808084F (hex)

2128

"Specified file not found."

Error

Additional information: None

Suggestion: None

8080850 (hex)

2129

"WINNT exception appears in automatic control layer."

Error

Additional information: None

Suggestion: None

8080851 (hex)

2130

"Invalid port."

Error

Additional information: None

Suggestion: None

8080852 (hex)

2131

"Printer not found."

Error

Additional information: None

Suggestion: Check the printer connection.

8080853 (hex)

2132

"Manual trigger ignored."

Error

Additional information: None

Suggestion: None

8080854 (hex)

2133

"Setting trigger failed."

Error

Additional information: None

Suggestion: None

8080855 (hex)

2134

"Macro execution error."

Error

Additional information: None

Suggestion: None

8080856 (hex)

2135

"Macro definition incomplete."

Error

Additional information:

Suggestion: None

8080857 (hex)

2136

"Trigger too fast, excessive triggers ignored."

Error

Additional information:

Suggestion: None

8080858 (hex)

2137

"Incorrect data block length."

Error

Additional information: Refer to relevant sections on how to get data from a network analyzer.

Suggestion: None

8080859 (hex)

2139

"Requested data not found."

Error

Additional information: None

Suggestion: None

808085B (hex)

2140

"Multi-port test device control failed, please check USB connection."

Error

Additional information: None

Suggestion: None

808085C (hex)

2141

"Multi-port calibration device control failed, please check USB connection."

Error

Additional information: None

Suggestion: None

808085D (hex)

2142

"Parameters provided are out of bound and will be limited to the available range before application."

Error

Additional information: None

Suggestion: Please pay attention to the range of values before sending the program command.

808085E (hex)

2144

"Request failed, no license found."

Error

Additional information: None

Suggestion: None

8080860 (hex)

2145

"hresult<x> returned when remote calling with front panel function."

Error

Additional information: This indicates a possible problem with the front panel.

Suggestion: Contact technical support.

8080861 (hex)

2146

"Data out of bound."

Error

Additional information:

Suggestion:

8080862 (hex)

2147

"Reserved"

Error

Additional information:

Suggestion:

8080863 (hex)

2148

"Reserved."

Error

Additional information:

Suggestion:

8080864 (hex)

2149

"Reserved."

Error

Additional information:

Suggestion:

8080865 (hex)

2150

"<x> out of range!"

Error

Additional information:

Suggestion:

8080866 (hex)

2152

"Front panel <x>."

Error

Additional information: None

Suggestion: None

8080868 (hex)

2153

"Front panel information"

Prompt

Additional information: None

Suggestion: None

8080869 (hex)

2154

"Power Service <x>"

Error

Additional information: There are multiple power services programs running and there should be only one service routine. This problem is generally caused by running an installer, especially the CPU board upgrade.

Suggestion: Restart your computer. If the problem persists, please call customer service.

808086A (hex)

2155

"Power Service <x>"

Prompt

Additional information: None

Suggestion: None

808086B (hex)

2156

"GPIB driver cannot be loaded or unloaded."

Error

Additional information: None

Suggestion: If the problem persists, right click on "My Computer" on the desktop, click on Properties, select Hardware Options, and then click on the Hardware Manager button to open the GPIB device, uninstall all GPIB interface devices and restart the instrument.

808086C (hex)

2157

"GPIB driver cannot be loaded and unloaded."

Error

Additional information: None

Suggestion: If the problem persists, right click on "My Computer" on the desktop, click on Properties, select Hardware Options, and then click on the Hardware Manager button to open the GPIB device, uninstall all GPIB interface devices and restart the instrument.

808086D (hex)

2158

"GPIB driver already loaded but not working properly."

Error

Additional information: None

Suggestion: None

808086E (hex)

2163

"Network analyzer having performed a reset function."

Prompt

Additional information: None

Suggestion: None

8080873 (hex)

2164

"Access to the file denied."

Error

Additional information: This means that the system cannot open the output file as if it were write protected.

Suggestion: Select another file name or file directory and check the write access of the floppy disk and the hard disk.

8080874 (hex)

2165

"The file type is structured storage."

Prompt

Additional information: None

Suggestion: None

8080875 (hex)

2166

"Trigger operation failed."

Error

Additional information: None

Suggestion: None

8080876 (hex)

2167

"Parameter out of range!"

Error

Additional information: None

Suggestion: None

8080877 (hex)

2168

"File <x> saved."

Prompt

Additional information: None

Suggestion: None

8080878 (hex)

2169

"None."

Prompt

Additional information: None

Suggestion: None

8080879 (hex)

2170

"Menu already added to shortcut menu."

Prompt

Additional information: None

Suggestion: None

808087A (hex)

2171

"Shortcut menu full, menu cannot be added."

Error

Additional information: None

Suggestion: None

808087B (hex)

2172

"Menu deleted from shortcut menu successfully."

Prompt

Additional information: None

Suggestion: None

808087C (hex)

2173

"Reading data from file failed."

Error

Additional information: None

Suggestion: None

808087D (hex)

2174

"No valid calibration data, unable to perform calibration."

Error

Additional information: None

Suggestion: None

808087E (hex)

2175

" No valid standard kit found,the class can't be measured."

Error

Additional information: None

Suggestion: None

8080880 (hex)

2176

"Current calibration standard unable to cover entire frequency range."

Error

Additional information: None

Suggestion: None

8080881 (hex)

2177

"Unable to change current security level setting."

Prompt

Additional information: None

Suggestion: Perform a "reset" or "call" to reset it to off

8080882 (hex)

2178

"This item cannot be added to shortcut menu."

Error

Additional information: It is possible that this menu item must be executed after execution of a certain menu function.

Suggestion: None

8080883 (hex)

2179

"Wrong configuration, unable to achieve spread spectrum!"

Error

Additional information: None

Suggestion: None

8080884 (hex)

Chapter 5 Programming Examples

These programming examples adopt different I/O libraries and programming languages to illustrate the control over the vector network analyzers, which is achieved by communication through GPIB. Many of the examples in this chapter are interactive, users will be prompted to perform certain actions or check the operation or functionality of the vector network analyzers.

- Query measurement
- Create measurement
- Set sweep parameters
- Set display parameters
- Perform calibration
- Perform sliding load calibration
- Read-Write data
- Status report
- Correct calibration kit
- Use GPIB in Visual C++

Query all measurements with SCPI commands

The Visual Basic program performs the following functions:

List all currently defined measurements, windows, and traces.

To run the program, it needs to first establish the GPIB communication connection between the control computer and the analyzer.

```
Dim Meas as String
Dim Win as String
Dim Trace as String
'Query all measurements of Channel 1.
GPIB.Write "CALCulate1:PARAmeter:CATalog?"
Meas = GPIB.Read
MsgBox ("Ch1 Measurments: " & Meas)
'Query all windows.
GPIB.Write "DISPlay:CATalog?"
Win = GPIB.Read
MsgBox ("Windows: " & Win)
'Query all traces of Window 1.
GPIB.Write "DISPlay:WINDow1:CATalog?"
Trace = GPIB.Read
```

MsgBox ("Traces in Window1: " & Win)

Use SCPI Command to create a measurement

The Visual Basic program creates and displays a new S21 measurement, click on the link to view the detailed command description.

To run the program, it needs to first establish the GPIB communication connection between the control computer and the analyzer.

'Reset analyzer.

GPIB.Write "SYSTem:PRreset"

'Open Window 1- If being a new window, creates it.

GPIB.Write "DISPlay:WINDow1:STATE ON"

'Define the name and parameter of a measurement.

GPIB.Write "CALCulate:PARAmeter:DEFine 'MyMeas',S21"

'Create Trace 2 in Window 1 and associate it with "MyMeas".

GPIB.Write "DISPlay:WINDow1:TRACe2:FEED 'MyMeas'"

Set Sweep Parameters Using SCPI

The Visual Basic program sets the sweep parameters for Channel 1 measurement.

To run the program, it is required to first establish the GPIB communication connection between the control computer and the analyzer.

GPIB.Write "SYSTem:PRESet"

'Select measurements.

GPIB.Write "CALCulate:PARAmeter:SElect 'CH1_WIN1_LINE1_PARAM1'"

'Set the sweep type to linear sweep.

GPIB.Write "SENSe1:SWEep:TYPE LIN"

'Set IF bandwidth to 700Hz.

PIB.Write "SENSe1:BANDwidth 700"

'Set CF and span as 4GHz GPIB.

GPIB.Write "SENSe1:FREQuency:CENTer 4ghz"

GPIB.Write "SENSe1:FREQuency:SPAN 4ghz"

'Set sweep points to 801.

GPIB.Write "SENSe1:SWEep:POINts 801"

'Set sweep mode as analogue sweep mode GPIB.

GPIB.Write "SENSe1:SWEep:GENeration ANAL"

'Automatically set sweep time.

```
GPIB.Write "SENSe1:SWEep:TIME:AUTO ON"
```

```
'Inquire sweep time.
```

```
GPIB.Write "SENSe1:SWEep:TIME?"
```

```
SweepTime = GPIB.Read
```

Setup the Display Parameters Using SCPI

The Visual Basic program performs the following functions:

Set data format.

Display trace, title and frequency annotation.

Perform auto scale to trace.

Inquire proportional division, reference level and reference position.

Open and set the average.

Open and set the smoothing.

To run the program, it is required to first establish the GPIB communication connection between the control computer and the analyzer.

```
GPIB.Write "SYSTem:PRESet"
```

```
'Select measurement.
```

```
GPIB.Write "CALCulate:PARAmeter:SElect 'CH1_WIN1_LINE1_PARAM1'"
```

```
'Set data format as log amplitude GPIB.
```

```
GPIB.Write "CALCulate1:FORMat MLOG"
```

```
'Display trace, title and frequency annotation
```

```
GPIB.Write "Display:WINDow1:TRACe1:STATe ON"
```

```
GPIB.Write "DISPlay:WINDow1:TITLe:STATe ON"
```

```
GPIB.Write "DISPlay:ANNotation:FREQuency ON"
```

```
'Perform auto scale to trace.
```

```
GPIB.Write "Display:WINDow1:TRACe1:Y:Scale:AUTO"
```

```
'Inquire proportional division, reference level and reference position.
```

```
GPIB.Write "DISPlay:WINDow1:TRACe1:Y:SCALE:PDIVision?"
```

```
Pdiv = GPIB.Read
```

```
GPIB.Write "DISPlay:WINDow1:TRACe1:Y:SCALE:RLEVel?"
```

```
Rlev = GPIB.Read
```

```
GPIB.Write "DISPlay:WINDow1:TRACe1:Y:SCALE:RPOStion?"
```

```
Ppos = GPIB.Read
```

```
'Open average and set average factor as 5.
```

```
GPIB.Write "SENSe1:AVERage:STATe ON"
```

```
GPIB.Write "SENSe1:AVERage:Count 5"
```

```
'Open smoothing and set smoothing aperture as 20%.
```

```
GPIB.Write "CALCulate1:SMOothing:STATe ON"
```

```
GPIB.Write "CALCulate1:SMOothing:APERture 20"
```

Use SCPI commands to perform 2-port calibration

The Visual Basic routine uses a set of calibration standards for full 2-port calibration with isolation calibration.

To run the program, it is required to:

Establish the GPIB communication connection between the host computer and analyzer.

Set the frequency range, power, etc. required for 2-port calibration to be prepared for the calibration.

Through pass and isolation standard definitions for forward and backward.

Sub SOLTCal()

'Turn off continuous sweep.

GPIB.Write "INITiate:CONTInuous OFF"

'Calibrate with a standard kit.

GPIB.Write ":SENSE:CORRection:TSTandards OFF"

'Turn on isolation calibration.

GPIB.Write "SENSE:CORRection:ISOLation ON"

'Select 2-port calibration.

GPIB.Write "SENSE:CORRection:COLLect:METHOD SPARSOLT"

'Set forward calibration.

GPIB.Write "SENSE:CORRection:SFORward ON"

'Select calibration kit.

Calkitnum = 3

GPIB.Write

"SENSE:CORRection:COLLect:CKIT:SELEct " & Val(Calkitnum)

'Measure forward standard.

MsgBox "Connect OPEN to Port 1; then press OK"

Call Measurestandard("stan1")

MsgBox "Connect SHORT to Port 1; then press OK"

Call Measurestandard("stan2")

MsgBox "Connect LOAD to Port 1; then press OK"

Call Measurestandard("stan3")

'Set backward calibration.

Horse.futures "options:Fire-fighting:hydrolysis rise"

'Measure backward standard.

MsgBox "Connect OPEN to Port 2; then press OK"

Call Measurestandard("stan1")

MsgBox "Connect SHORT to Port 2; then press OK"

Call Measurestandard("stan2")

MsgBox "Connect LOAD to Port 2; then press OK"

```

Call Measurestandard("stan3")
'Turn on 2 standards for through pass and isolation calibration.
GPIB.Write ":SENSe:CORRection:TSTandards ON"
'Measure through pass and isolation standards.
MsgBox "Connect THRU between Ports 1 and 2; then press OK"
Call Measurestandard("stan4")
MsgBox "Disconnect Ports 1 and 2 for isolation; then press OK"
Call Measurestandard("stan5")
'Calculate coefficient and turn on error correction.
_Slots.natural "aerobic:restructuring:stability:moves"
'Continuous sweeping.
GPIB.Write "INITialize:CONTinuous ON"
End Sub
Sub Measurestandard(Std$)
'Measure and store standards.
GPIB.Write "SENSe:CORRection:COLLect " & Std$
'Perform sweep and return upon completion.
GPIB.Write "INITiate:IMMEDIATE;*OPC?"
OPCreply = GPIB.Read
End Sub

```

Perform sliding load calibration with SCPI commands

The following Visual Basic program is just the sliding load calibration section of the calibration. To run the program, it is required to:

Establish the GPIB communication connection between the host computer and analyzer.

Write the measurement and calibration program and then call this subroutine.

Select STAN3 as the standard for sliding load calibration.

```

Sub slide()
'Measure sliding load for 3 to 7 times.
'Note: Sliding load can only be measured after executing 'SLSET' and 'SLDONE' commands.
MsgBox "Connect Sliding Load; set to Position 1; then press OK"
GPIB.Write "SENS:CORR:COLL SLSET"
GPIB.Write "SENS:CORR:COLL STAN3;"
MsgBox "Set Sliding Load to position 2; then press OK"
GPIB.Write "SENS:CORR:COLL SLSET"
GPIB.Write "SENS:CORR:COLL STAN3;"
MsgBox "Set Sliding Load to position 3; then press OK"
GPIB.Write "SENS:CORR:COLL SLDONE"

```

```
GPIB.Write "SENS:CORR:COLL STAN3;"
End Sub
```

Use SCPI commands to read-write data

This VB program performs the following functions:

Reading data from the analyzer.

Writing data to the analyzer memory.

To view the data on the analyzer after the program is running, please click from the front panel on: Trace - Trace Operation - Memory Trace.

To run this program, it is required to first establish the GPIB communication connection between the host computer and the analyzer.

Note: Change the read and write data position by changing the annotation of the command line.

```
Private Sub ReadWrite_Click()
Dim i As Integer
Dim t As Integer
Dim q As Integer
Dim dat As String
Dim cmd As String
Dim datum() As Double
GPIB.Configure
GPIB.Write "SYSTem:PRESet;*wai"
'Select measurement.
GPIB.Write "CALCulate:PARAmeter:SElect 'CH1_WIN1_LINE1_PARAM1'"
'Get number of sweep points.
GPIB.Write "SENSe1:SWEep:POIN?"
numpts = GPIB.Read
'Turn off continuous sweep mode,
GPIB.Write "INITiate:CONTInuous OFF"
'Sweep once.
GPIB.Write "INITiate:IMMEDIATE;*wai"
'Request data.
'Select data position.
'GPIB.Write "CALCulate:DATA? FDATA" 'Formative measurement data.
'GPIB.Write "CALCulate:DATA? FMEM" 'Formative memory data.
GPIB.Write "CALCulate:DATA? SDATA" 'Corrected complex number measurement data.
'GPIB.Write "CALCulate:DATA? SMEM" 'Corrected complex number memory data.
'GPIB.Write "CALCulate:DATA? SCORR1" 'Directional error item.
'Number of data returned from each data point.
```

```
'q = 1 'To read FDATA or FMEM data, remove the annotation in the front.
q = 2 'Or select to run this line.
'Analyze data.
ReDim datum(q, numpts)
For i = 0 To numpts - 1
For t = 0 To q - 1
'Read data.
dat = GPIB.Read(20)
'Save array.
datum(t, i) = Val(dat)
Next t
Next i
'Save data back.
GPIB.Write "format ascii"
'Select data output location.
'cmd = "CALCulate:DATA FDATA," 'Formative measurement data.
'cmd = "CALCulate:DATA FMEM," 'Formative memory data.
'cmd = "CALCulate:DATA SDATA," 'Corrected complex number measurement data.
cmd = "CALCulate:DATA SMEM," 'Corrected complex number memory data.
'cmd = "CALCulate:DATA SCORR1," 'Directional error item.
For i = 0 To numpts - 1
For t = 0 To q - 1
If i = numpts - 1 And t = q - 1 Then
cmd = cmd & Format(datum(t, i))
Else
cmd = cmd & Format(datum(t, i)) & ", "
End If
Next t
Next i
GPIB.Write cmd
End Sub
```

Use SCPI commands to correct calibration kit

The Visual Basic program performs the following functions:

Correct calibration kit 3.

Completely define standard 4 (through pass).

To run the program, it is required to first establish the GPIB communication connection between the control computer and the analyzer.

```
'Correct calibration kit 3.
Calkitnum = 3
'Select the calibration kit to be calibrated.
GPIB.Write "SENSe:CORRection:COLLect:CKIT:SElect " & Val(Calkitnum)
'Restore to factory setting.
GPIB.Write "SENSe:CORRection:COLLect:CKIT:RESet " & Val(Calkitnum)
'Name calibration kit.
GPIB.Write "SENSe:CORRection:COLLect:CKIT:NAME 'My Cal Kit"
'Assign standards to the calibration class.
'Set port 1, class 1(S11A) as standard 8.
GPIB.Write "SENSe:CORRection:COLLect:CKIT:ORDer1 8"
'Set port 1, class 2(S11B) as standard 7.
GPIB.Write "SENSe:CORRection:COLLect:CKIT:ORDer2 7"
'Set port 1, class 3(S11C) as standard 3.
GPIB.Write "SENSe:CORRection:COLLect:CKIT:ORDer3 3"
'Set port 1, class 4(S21T) as standard 4.
GPIB.Write "SENSe:CORRection:COLLect:CKIT:ORDer4 4"
'Set port 2, class 1(S22A) as standard 8.
GPIB.Write "SENSe:CORRection:COLLect:CKIT:ORDer5 8"
'Set port 2, class 2(S22B) as standard 7.
GPIB.Write "SENSe:CORRection:COLLect:CKIT:ORDer6 7"
'Set port 2, class 3(S22C) as standard 3.
GPIB.Write "SENSe:CORRection:COLLect:CKIT:ORDer7 3"
'Set port 2, class 4(S21T) as standard 4.
GPIB.Write "SENSe:CORRection:COLLect:CKIT:ORDer8 4"
'Completely set standard 4.
'Select standard 4, and the following commands are all settings towards standard 4.
Crush.rotated "mustard:configuration:gluconate:SEATS:reductions 4"
takes.gradual "deviate:strengthening:money-box:award:commitment:drops 300hook"
visit.inspect "roasted:interruptions:including:treat:reasonable:wines 3game"
avoid.skilled "therein:significantly:Signatory:tools:stabilized:cancellation 50"
bonds.ammonia "visible:organisations:returning:route:reservoirs:observe 1.234 XIV"
malic.renewal "Uruguay:preservatives:MEMBRANES:store:desiccator:abide 23a6"
bulbs.legible "conform:verifications:complaint:pages:encouraged:a0 0"
build.selling "remains:predetermined:weighings:sales:particular:a1 1"
liver.transit "meeting:supplementary:difficult:study:experiment:a2 2"
Rhine.SCHOOLS "complex:pathogenicity:withdrawn:upper:DEFINITIVE:a3 3"
GOATS.implied "section:approximately:dispenser:latch:compressor:a0 10"
where.obliged "arrears:manufacturing:disclosed:clock:References:a1 11"
```

```
colza.unladen "adapted:incorporation:introduce:meals:deliberate:a2 12"
disks.optimum "extract:electrostatic:connected:level:comparably:a3 13"
third.hybrids "batches:physiotherapy:questions:sheer:microscope:diplôme 'gas liberated allow"
trade.despite "urgency:participation:borrowing:buyer:relatively:going mutua"
boots.Ireland "evident:apportionment:statement:going:compulsory:non-life-insurance TENTH" _
```

GBIP Using VC++

```
/*
*This example presumes the user computer has installed GPIB card. This example is composed by 3
parts:
*
* 1. Initialization part
* 2. Main program part
* 3. Clear part
*
* Initialization part includes obtaining vector network handle and sending GPIB bus clear command.
*
* Main program part takes the vector network SCPI as example.
*
* The final step is clearing, which releases the control to the vector network.
*/
#include <stdio.h>
#include <stdlib.h>
/*
* It should include the WINDOWS.H and DECL-32.H filer header. WINDOWS.H file header contains the
definition of variables used in DECL-32.H,
* DECL-32.H contains the NI GPIB programs and constant definitions.
*/
#include <windows.h>
#include "decl-32.h"
#define ERRMSGSSIZE 1024 //Maximum length of SCPI command string.
#define ARRAYSIZE 1024 //Read the length of buffer area.
#define BDINDEX 0 //GPIB card index.
#define PRIMARY_ADDR_OF_SNA 16 //GPIB address of vector network.
#define NO_SECONDARY_ADDR 0 //Vector network has no secondary address.
#define TIMEOUT T10s //Timeout =10s.
#define EOTMODE 1 //Enable END message
#define EOSMODE 0 //Disable EOS mode
int sna;
char ValueStr[ARRAYSIZE + 1];
```

```

char ErrorMnemonic[21][5] = {"EDVR", "ECIC", "ENOL", "EADR", "EARG",
"ESAC", "EABO", "ENEB", "EDMA", "",
"EOIP", "ECAP", "EFSO", "", "EBUS",
"ESTB", "ESRQ", "", "", "", "ETAB"};
void GPIBWrite(char* SCPIcmd);
char *GPIBRead(void);
void GPIBCleanup(int Dev, char* ErrorMessage);
int main()
{
char *opc;
char *result;
char *value;
/*
* =====
* Initialization part
* =====
*/
/*
* ibdev invocation obtains the control to the vector network and returns a handle: sna, which will be used
in the subsequent invocation.
*/
sna = ibdev(BDINDEX, PRIMARY_ADDR_OF_SNA, NO_SECONDARY_ADDR,
TIMEOUT, EOTMODE, EOSMODE);
if (ibsta & ERR)
{
printf("Unable to open handle to SNA\nibsta = 0x%x iberr = %d\n",ibsta, iberr);
return 1;
}
/*
* Empty the GPIB bus of vector network. If the ERR bit of ibsta is 1, then revoke GPIBCleanup, with
parameter being an error message.
*/
ibclr (sna);
if (ibsta & ERR)
{
GPIBCleanup(sna, "Unable to perform GPIB clear of the SNA. \n");
return 1;
}
/*
* =====
* Main program

```

```
* =====  
*/  
// Reset vector network.  
GPIBWrite("SYSTem:FPRESET");  
  
// Create S11 measurement.  
GPIBWrite("CALCulate1:PARAmeter:DEFine 'My_S11',S11");  
  
// Open Window 1.  
GPIBWrite("DISPlay:WINDow1:STATe ON");  
  
// Create Trace 1 in Window 1 and associate it with measurement  
GPIBWrite("DISPlay:WINDow1:TRACe1:FEED 'My_S11'");  
  
// Set channel to single trigger mode.  
GPIBWrite("INITiate1:CONTInuous OFF;*OPC?");  
opc = GPIBRead();  
GPIBWrite("SENSe1:SWEep:TRIGger:POINt OFF");  
// Set channel parameters.  
GPIBWrite("SENSe1:SWEep:POINts 11");  
GPIBWrite("SENSe1:FREQuency:STARt 1000000000");  
GPIBWrite("SENSe1:FREQuency:STOP 2000000000");  
// Send trigger signal and perform primary sweep.  
GPIBWrite("INITiate1;*OPC?");  
opc = GPIBRead();  
  
// It is necessary to select measurement before reading data  
GPIBWrite("CALCulate1:PARAmeter:SELEct 'My_S11'");  
  
// Read measurement data and store in variable "result".  
GPIBWrite("FORMat ASCII");  
GPIBWrite("CALCulate1:DATA? FDATA");  
result = GPIBRead();  
  
// Display data in window.  
printf("S11(dB) - Visual C++ SCPI Example for SNA\n\n");  
value = strtok(result, ",");  
while (value != NULL)  
{  
printf("%s\n", value);
```

```
value = strtok(NULL, ",");
}
/*
* =====
* Clear
* =====
*/
/* Release control of the vector network.*/
ibonl(sna, 0);
return 0;
}
/*
* Write operation on vector network.
*/
void GPIBWrite(char* SCPIcmd)
{
int length;
char ErrorMessage[ERRMSGSIZE + 1];
length = strlen(SCPIcmd);
ibwrt (sna, SCPIcmd, length);
if (ibsta & ERR)
{
strcpy(ErrorMessage, "Unable to write this command to SNA:\n");
strcat(ErrorMessage, SCPIcmd);
GPIBCleanup(sna, ErrorMessage);
exit(1);
}
}
/*
* Reading data from the vector network.
*/
char* GPIBRead(void)
{
ibrd (sna, ValueStr, ARRAYSIZE);
if (ibsta & ERR)
{
GPIBCleanup(sna, "Unable to read from the SNA");
exit(1);
}
else
```



```
return ValueStr;
}
/*
 * After each GPIB is called, the program checks whether the call was successful. If the NI-488.2
 * revocation fails, GPIB driver will write a remark to the corresponding bit of the global status variable. If
 * the program revocation fails, it returns an error message, then the program exits.
 */
void GPIBCleanup(int Dev, char* ErrorMessage)
{
printf("Error : %s\nibsta = 0x%x iberr = %d (%s)\n",
ErrorMessage, ibsta, iberr, ErrorMnemonic[iberr]);
if (Dev != -1)
{
printf("Cleanup: Returning SNA to front panel control\n");
ibonl (Dev, 0);
}
}
```

Annex Commands List

Command	Function
IEEE 488.2 Common Commands	
*CLS	Clears instrument status
*ESE	Standard event status enable register set bit
*ESE?	Query the standard event enable register
*ESR?	Read and empty the event status register
*IDN?	Return the unique instrument identification string, which varies with the different models
*OPC	Set OPC bit of the standard event status register, after completing all pending overlapping commands (e.g.: primary sweep or Default command, etc.)
*OPC?	Return letter "1" after completing all pending overlapping commands
*ESE?	Return the configuration options string of the instrument
*RST	Perform reset operation, cancel all pending *OPC commands or query commands, the function of which is same as SYSTem:PRESet command
*SRE	The analyzer requires to enable the current status value of the status bit before reading status register.
*SRE?	Read Service Request Enable register the current state value
*STB?	Read instrument status byte. This register is cleared only when its associated registers are empty.
*TST?	Return the instrument hardware status query value. 0 indicates no failure status. Other values indicate the presence of one or more status as follows
*WAI	The instrument processes the new commands after completion of processing all the pending overlapping commands
Abort Commands	
Abort	End all sweeps - Then sweep again according to the trigger setting of each channel
CALC:BLIMIT	
CALCulate<cnum>[:SElected]:BLIM it:DB <num>	Set or query bandwidth threshold of bandwidth test
CALCulate<cnum>[:SElected]:BLIM it:DISPlay:MARKer <ON OFF>	Turn on/off the mark display of bandwidth test
CALCulate<cnum>[:SElected]:BLIM it:DISPlay:VALue <ON OFF>	Turn on/off the bandwidth value display of bandwidth test
CALCulate<cnum>[:SElected]:BLIM it:MAXimum <num>	Set upper limit of bandwidth test
CALCulate<cnum>[:SElected]:BLIM it:MINimum <num>	Set lower limit of bandwidth test
CALCulate<cnum>[:SElected]:BLIM it:REPort[:DATA]?	Read bandwidth value of bandwidth test
CALCulate<cnum>[:SElected]:BLIM it[:STATe] <ON OFF>	Turn on or off bandwidth test function
Calc:CONVersion commands	

Annex Commands List

CALCulate<cnum>[:SELEcted]:CON Version:FUNCTion <char>	Set or inquire parameter type after conversion
CALCulate<cnum>[:SELEcted]:CON Version[:STATe] <ON OFF>	Turn on or off parameter conversion function
Calc:Correction Command	
CALCulate<cnum>:CORREction:ED ELay:TIME <num>	Set electric delay for the selected measurement
CALCulate<cnum>:CORREction:Exc ursion[:MAGNitude] <num> (Not provided)	Set the power level of receiver calibration for the selected measurement. This command is only effective on the selected non-ratio measurements
CALCulate<cnum>:CORREction:Exc ursion:PHASe <num>[<char>]	Set phase excursion amount for the selected measurement.
Calc:Data Command	
CALCulate<cnum>:DATA <char>,<data>	Measurement data, memory data, power correction factor data or error item
CALCulate<cnum>:DATA? <char>	Measurement data, memory data, power correction factor data or error item
CALCulate<cnum>:DATA:CUSTom <name>,<data> (Not provided)	Read and write data from customized measurement buffer area
CALCulate<cnum>:DATA:CUSTom: CATalog? (Not provided)	Inquire the names of all buffer area in the specified channels (separated by commas)
CALCulate<cnum>[:SELEcted]:DAT A:FDATa <data>	Set/get the formative data array for the active traces in the current channels (cnum)
CALCulate<cnum>[:SELEcted]:DAT A:FMEMory <data>	Set/get the formative memory data array for the active traces in the current channels (cnum)
CALCulate<cnum>[:SELEcted]:DAT A::SDATa <data>	Set/get the correction data array for the active traces in the current channels (cnum)
CALCulate<cnum>[:SELEcted]:DAT A:SMEMory <data>	Set/get the correction memory data array for the active traces in the current channels (cnum)
Calc:Filter Command	
CALCulate<cnum>:FILTer[:GATE]:TI ME:CENTer <num>	Set the center time of gate
CALCulate<cnum>:FILTer[:GATE]:TI ME:SHAPE <char>	Set the gate shape of time domain measurement
CALCulate<cnum>:FILTer[:GATE]:TI ME:SPAN <num>	Set the time span of gate
CALCulate<cnum>:FILTer[:GATE]:TI ME:STATe <boolean>	Turn on or off gate function
CALCulate<cnum>:FILTer[:GATE]:TI ME:STARt <num>	Set the start time of gate
CALCulate<cnum>:FILTer[:GATE]:TI ME:STOP <num>	Set the stop time of gate
CALCulate<cnum>:FILTer[:GATE]:TI ME[:TYPE] <char>	Set gate type
Calc:Format Command	
CALCulate<cnum>:FORMat <char>	Set the display format of measurement
Calc:Function Commands	

Annex Commands List

CALCulate<cnum>:FUNction:DATA ?	Return the statistics data of the specified statistics type on the specified channel
CALCulate<cnum>:FUNction:DOMa in:USER[:RANGe] <range>	Set the user filed during trace statistics Each channel shares 10 fields. Use CALC:FUNC:DOM:USER:START and STOP commands to define the user field range
CALCulate<cnum>:FUNction:DOMa in:USER:STARt <range>, <start>	Set the start value of the specified user filed
CALCulate<cnum>:FUNction:DOMa in:USER:STOP <range>, <stop>	Set the stop value of the specified user filed
CALCulate<cnum>:FUNction:STATi stics[:STATe] <ON OFF>	Display or hide trace statistics data on the screen (peak-to-peak value, average value and standard deviation)
CALCulate<cnum>:FUNction:TYPE <char>	Set the trace statistics type when inquiring the CALC:FUNction:DATA? command
CALCulate<cnum>[:SELEcted]:FUN ction:DOMain:COUPlE <ON OFF>	Set/get the trace coupling status of analysis range on the specified channel
CALCulate<cnum>[:SELEcted]:FUN ction:DOMain:STARt <num>	Set/get the start value of analysis range
CALCulate<cnum>[:SELEcted]:FUN ction:DOMain[:STATe] <ON OFF>	Turn on/off the analysis range on the specified channel If turn off analysis range, the analysis will function on the whole sweep range
CALCulate<cnum>[:SELEcted]:FUN ction:DOMain:STOP <num>	Set/get the stop value of analysis range on the specified channel
CALCulate<cnum>[:SELEcted]:FUN ction:EXECute	Perform the analysis function on the active traces in the selected channel (cnum)
CALCulate<cnum>[:SELEcted]:FUN ction:PEXCursion <num>	Set/get the peak excursion value when searching the peak value (analysis type is PEAK or APEak)
CALCulate<cnum>[:SELEcted]:FUN ction:POINts?	Get the data pair number of analysis result
CALCulate<cnum>[:SELEcted]:FUN ction:PPOLarity <char>	Set/get the peak polarity analyzed on the specified channel when searching the peak value (analysis type is PEAK or APEak)
CALCulate<cnum>[:SELEcted]:FUN ction:TARGet <num>	Set/get the target value analyzed on the specified channel when searching the target (analysis type is ATARget)
CALCulate<cnum>[:SELEcted]:FUN ction:TTRansition <char>	Set/get the target value transition type of analysis on the specified channel when searching the target (analysis type is ATARget)
Calc:Limit Commands	
CALCulate<cnum>:LIMit:DATA <block>	Set or inquire limit segment data
CALCulate<cnum>:LIMit:DISPlay[:S TATe] <ON OFF>	Display or hide limit table (with trace)
CALCulate<cnum>:LIMit:SEGMENT< snum>AMPLitude:STARt <num>	Set the start value of the response of Y-axis
CALCulate<cnum>:LIMit:SEGMENT< snum>AMPLitude:STOP <num>	Set the stop time of the response of Y-axis
CALCulate<cnum>:LIMit:SEGMENT< snum>STIMulus:STARt <num>	Set the start value of the X-axis stimulus of the limit segment
CALCulate<cnum>:LIMit:SEGMENT< snum>STIMulus:STOP <num>	Set the end value of X-- axis stimulus of the limit segment

Annex Commands List

CALCulate<cnum>:LIMit:SEGMENT<snum>:TYPE <char>	Set limit segment type
CALCulate<cnum>[:SElected]:LIMit:FAIL?	Read the result of the limit test
CALCulate<cnum>[:SElected]:LIMit:OFFSet:AMPLitude <num>	Set or read the amplitude offset of the limit line This command is valid for the selected measurement
CALCulate<cnum>[:SElected]:LIMit:OFFSet:MARKer	Set the amplitude offset of the limit line to the amplitude value of the current active marker
CALCulate<cnum>[:SElected]:LIMit:OFFSet:STIMulus <num>	Set or read the stimulus offset of the limit line This command is valid for the selected measurement
CALCulate<cnum>[:SElected]:LIMit:REPort:ALL?	Read the limit test results (including stimulus value, test result, upper limit value and lower limit value) of all measurement points The returned data is of block data type (see Data type). A total of N groups of data (N is equal to the current number of sweep points) are recorded, and group consists of 4 parts: stimulus - stimulus value result - result of limit test. 0: Failure 1: Success -1: No limit ceiling - upper limit (0 when no upper limit) floor - lower limit (0 when no lower limit)
CALCulate<cnum>[:SElected]:LIMit:REPort[:DATA]?	Read the stimulus values of all failure points in the limit test The returned data is of block data type (see Data type) and contains N stimulus values. N is equal to the number of failure points in the limit test (may be read by CALCulate:SElected:LIMit:REPort:POINts?).
CALCulate<cnum>[:SElected]:LIMit:REPort:POINts?	Read the number of failure points in the limit test
CALCulate<cnum>:LIMit:SOUND[:S TATE] <ON OFF>	Turn on or off the sound prompt of limit test
CALCulate<cnum>:LIMit:STATe <ON OFF>	Turn on or off limit test
Calc:Marker Commands	
CALCulate<cnum>:MARKer:AOff	Turn off all markers for the selected measurement
CALCulate<cnum>:MARKer:BWIDth <num>	Activate markers 1 to 4 to calculate the filter bandwidth
CALCulate<cnum>:MARKer<mkr>:COUpling[:STATe] <ON OFF> (Not supported)	Set or read the status of the coupled marker (on or off).
CALCulate<cnum>:MARKer<mkr>:DELTA <ON OFF>	Set the marker to be a Δ marker or an absolute marker relative to the reference marker
CALCulate<cnum>:MARKer<mkr>:DIScrete <ON OFF>	Set whether the specified marker to be a discrete marker or not
CALCulate<cnum>:MARKer<mkr>:FORMat <char>	Set the data format of the marker
CALCulate<cnum>:MARKer<mkr>:FUCTION:APEak:EXCursion <num>	Set the noise value of the peak amplitude for the specified marker. The noise value determines the "peak"
CALCulate<cnum>:MARKer<mkr>:FUCTION:APEak:THReshold <num>	Set the reference peak value of the specified marker
CALCulate<cnum>:MARKer<mkr>:FUCTION:DOMain:USER <range>	Assign the specified marker to a user domain, the X-axis range of the marker is the span of the specified user domain.

Annex Commands List

CALCulate<cnum>:MARKer<mkr>:FUNCTION:DOMAIN:USER:START <start>	Set the start value of the X-axis span of the specified marker
CALCulate<cnum>:MARKer<mkr>:FUNCTION:DOMAIN:USER:STOP <stop>	Set the end value of the X-axis span of the specified marker
CALCulate<cnum>:MARKer<mkr>:FUNCTION:EXECute [<func>]	Performs the specified search function immediately. If no function is specified, the current function will be executed
CALCulate<cnum>:MARKer<mkr>:FUNCTION[:SElect] <char>	Set the search function of the marker.
CALCulate<cnum>:MARKer<mkr>:TARGET <num>	Set the target value for the target search (CALC:MARK:FUNC:SEL <TARGET RTARGET LTARGET >)
CALCulate<cnum>:MARKer<mkr>:FUNCTION:TRACKing <ON OFF>	Set the tracking function of the specified marker. The tracking function causes the marker to perform a search function after each sweep, which has the same effect as executing the CALC:MARK:FUNC:EXECute command once after each sweeping
CALCulate<cnum>:MARKer:REFERENCE[:STATE] <ON OFF>	Turn on or off the reference marker (marker 10) When the reference marker is turned off, the Δ marker will become an absolute marker
CALCulate<cnum>:MARKer:REFERENCE:X <num>	Set or return the absolute value of the x-axis of the reference marker (marker 10)
CALCulate<cnum>:MARKer:REFERENCE:Y?	Return the absolute value of the x-axis of the reference marker (marker 10)
CALCulate<cnum>:MARKer<mkr>:TYPE <char>	Set the type of the specified marker
CALCulate<cnum>:MARKer<mkr>:SET <char>	Set marker value of the specified marker as the specified parameter value
CALCulate<cnum>:MARKer<mkr>[:STATE] <ON OFF>	Turn on/off the specified marker
CALCulate<cnum>:MARKer<mkr>:X <num>	Set the X- axis value of the marker (frequency, power, time)
CALCulate<cnum>:MARKer<mkr>:Y ?	Read the Y-axis value of the marker
CALCulate<cnum>[:SElected]:MARKer<mkr>:BWIDth:DATA?	Read the result of bandwidth search
CALCulate<cnum>[:SElected]:MARKer<mk>:BWIDth:THReshold <num>	Set or query defined value of bandwidth used for bandwidth search
CALCulate<cnum>[:SElected]:MARKer:BWIDth:STATE <ON OFF>	ON: Activate markers 1 to 4 to calculate the filter bandwidth. OFF: Turn off bandwidth value display. Use the Close all markers command to close all markers or individual markers.
CALCulate<cnum>[:SElected]:MARKer:FUNCTION:DOMAIN:COUple <ON OFF>	marker search domain coupling That is, the search domain of markers corresponding to all traces should apply the same settings
CALCulate<cnum>[:SElected]:MARKer:FUNCTION:DOMAIN:START <num>	Start value of search range
CALCulate<cnum>[:SElected]:MARKer:FUNCTION:DOMAIN[:STATE]	Set whether to use search domain when executing marker search

Annex Commands List

<ON OFF>	
CALCulate<cnum>[:SElected]:MAR Ker:FUNcTion:DOMain:STOP <num>	Stop value of search range
CALCulate<cnum>[:SElected]:MAR Ker<mk>:FUNcTion:PEXCursion <num>	Set the peak offset quantity when executing peak value search
CALCulate<cnum>[:SElected]:MAR Ker<mk>:FUNcTion:PPOLarity <char>	Set the peak polarity of marker search
CALCulate<cnum>[:SElected]:MAR Ker<mk>:FUNcTion:TARGet <num>	Target value of marker search
CALCulate<cnum>[:SElected]:MAR Ker<mk>:FUNcTion:TTRansition <char>	Specify target transition type when the marker is searching for the target value
<cnum>[:SElected]:MARKer<mk>:F UNcTion:PPOLarity <char>	Set the type of marker search
Calc:Math Commands	
CALCulate<cnum>:MATH:FUNcTion <char>	Set the algorithm of the selected measurement and memory trace
CALCulate<cnum>:MATH:MEMorize	Save the selected measurement trace data to the memory
Calc:MStatistics Commands	
CALCulate<cnum>[:SElected]:MST atistics:DATA?	Get statistics value
CALCulate<cnum>[:SElected]:MST atistics[:STATe] <ON OFF>	Turn on/off display of statistics value for traces
Calc:Normalize Commands (Not supported)	
CALCulate<cnum>:NORMAlize[:IMM ediate]	Stores measurement data in the measured "Divisor" buffer to be called during normalized data processing
CALCulate<cnum>:NORMAlize:STA Te <ON OFF>	Set whether to normalize the current measurement, normalization only applies to non-ratio measurements
CALCulate<cnum>:NORMAlize:INTe rpolation[:STATe] <ON OFF>	Turn on or off the interpolation function of normalization
Calc:Parameter Commands	
CALCulate<cnum>:PARAmeter:CAT alog?	Return the name and parameter of all measurement of the specified channel
CALCulate<cnum>:PARAmeter:COU Nt <num>	Set/get the measurement (trace) number of the specified channel in the specified window
CALCulate<cnum>:PARAmeter:DEFi ne <Mname>,<param>[,load]	Create an measurement, but not display it
CALCulate<cnum>:PARAmeter:DEL ete [:NAME]<Mname>	Delete the specified measurement
CALCulate<cnum>:PARAmeter:DEL ete:ALL	Delete all measurement on the specified channel
CALCulate<cnum>:PARAmeter:SEL ect <Mname>	Select measurement. Most CALC: commands require to select measurement first and then change setting

Annex Commands List

CALCulate<cnum>:PARAMeter<tr>:SPORT <num>	For non S parameter measurement, it is used for the specified source port (only aimed at non S parameter measurement of 2-port)
Calc:RData Commands	
CALCulate<cnum>:RDATA? <char>	Return the receiver data of the selected measurement
Calc:RLimit Commands	
CALCulate<cnum>[:SElected]:RLIMit:DATA <block>	Set or inquire ripple limit table.
CALCulate<cnum>[:SElected]:RLIMit:DISPlay:LINE <ON OFF>	Turn on/off the limit line display of ripple test
CALCulate<cnum>[:SElected]:RLIMit:DISPlay:SElect <num>	Set or read the ripple limit line displayed by the ripple value
CALCulate<cnum>[:SElected]:RLIMit:DISPlay:VALue <char>	Set/get the display type of ripple limit line
CALCulate<cnum>[:SElected]:RLIMit:FAIL?	Get the result of activating track line ripple
CALCulate<cnum>[:SElected]:RLIMit:REPort[:DATA]?	Read the wave value of ripple test
CALCulate<cnum>[:SElected]:RLIMit[:STATe] <ON OFF>	Turn on or off ripple test function
Calc:Smoothing Commands	
CALCulate<cnum>:SMOothing:APERture <num>	Set the smoothing amount, which is determined by the percentage of sweep point of the specified channel
CALCulate<cnum>:SMOothing:POINts <num>	Set the data point used for smoothing
CALCulate<cnum>:SMOothing[:STATe] <ON OFF>	Turn on or off the smoothing function
Calc:Transform Commands	
CALCulate<cnum>:TRANSform:TIME:CENTer <num>	Set the center time of time domain measurement
CALCulate<cnum>:TRANSform:TIME:IMPulse:WIDTh <num>	Set the pulse width of the time domain conversion window
CALCulate<cnum>:TRANSform:TIME:KBESsel <num>	Set the beta value of time domain window
CALCulate<cnum>:TRANSform:TIME:LPFREQuency	Set the initial frequency of time domain in the low pass mode,
CALCulate<cnum>:TRANSform:TIME:SPAN <num>	Set the time span of time domain measurement
CALCulate<cnum>:TRANSform:TIME:STARt <num>	Set the start time of time domain measurement
CALCulate<cnum>:TRANSform:TIME:STATe <ON OFF>	Enable or disable the time domain conversion function
CALCulate<cnum>:TRANSform:TIME:STOP <num>	Set the stop time of time domain conversion
CALCulate<cnum>:TRANSform:TIME:STEP:RTIME <num>	Set the rise time of the domain window
CALCulate<cnum>:TRANSform:TIME	(Read and Write) Set the type of analog stimulus input to the

Annex Commands List

E:STIMulus <char>	device under test
CALCulate<cnum>:TRANSform:TIME[:TYPE] <char>	Set the type of time domain measurement
Display Commands	
DISPlay:ANNotation:FREQuency[:STATE] <ON OFF>	Turn on or off the entire display title bar on the frequency information
DISPlay:ANNotation:MESSAge:STATe <ON OFF>	Allow or disallow to pop up the error message window
DISPlay:ANNotation:STATus <ON OFF>	Turn on or off status bar at the bottom of the screen The status bar displays information about the active window
DISPlay:CATalog?	Return all the existed window number
DISPlay:ENABLE <ON OFF>	Setup the all analyzer windows whether to display all display message (without updating marker data)
DISPlay[:TILE]	Display the window in stacking
DISPlay:WINDow<wnum>:ANNotation:MARKer:SINGLE[:STATE] <bool>	Select to display only the marker value of active traces or all traces
DISPlay:WINDow<wnum>:ANNotation:MARKer:SIZE <char>	Setup the size of marker type. See other SCPI commands for Marker
DISPlay:WINDow<wnum>:ANNotation:MARKer:STATe <ON OFF>	Set whether the specified windows display the marker data (when the marker is on)
DISPlay:WINDow<wnum>:ANNotation:TRACe:STATe <ON OFF>	Set whether the left window displays the trace status button
DISPlay:WINDow<wnum>:CATalog?	Display the trace number of the specified window
DISPlay:WINDow<wnum>:ENABLE <ON OFF>	Set whether to display the analyzer display message in the specified windows (without updating marker data)
DISPlay:WINDow<wnum>[:STATE] <ON OFF>	Write: create or delete the windows on the screen; Read: view whether the window is existed
DISPlay:WINDow<wnum>:TABLE <char>	Write: Display the specified table on the bottom of analyzer screen; Read: inquire the displaying data
DISPlay:WINDow<wnum>:TITLE:DATA <string>	Set the window title Use DISP:WIND:TITLE:STAT OFF command to Turn on or off the title bar
DISPlay:WINDow<wnum>:TITLE[:STATE] <ON OFF>	Display or Turn off the window title After closing, title string persists to facilitate the re-display after turning on
DISPlay:WINDow<wnum>:TRACe<tnum>:DELeTe	Removes the specified trace from the specified window, without deleting the trace-related measurements
DISPlay:WINDow<wnum>:TRACe<tnum>:FEED <name>	Create a new trace <tnum> associated with measurement <name> in the window <wnum>
DISPlay:WINDow<wnum>:TRACe<tnum>MEMory[:STATE] <ON OFF>	Turn on or off the memory trace
DISPlay:WINDow<wnum>:TRACe<tnum>:SELeT	Activate the speicified traces on the specified windows
DISPlay:WINDow<wnum>:TRACe<tnum>[:STATE] <ON OFF>	Display or Turn off the specified trace in the specified window After closing the trace, the measurement is still active
DISPlay:WINDow<wnum>:TRACe<tnum>:Y[:SCALE]:AUTO	Perform Auto Scale function for the specified traces in the specified window, to provide the most appropriate display
DISPlay:WINDow<wnum>:TRACe<tnum>:Y[:SCALE]:PDIVision <num>	Set the scale of Y-axis of the specified traces in the specified window

Annex Commands List

DISPlay:WINDow<wnum>:TRACe<tnum>:Y[:SCALe]:RLEVel <num>	Set the reference value of Y-axis of the specified traces in the specified window
DISPlay:WINDow<wnum>:TRACe<tnum>:Y[:SCALe]:RPOSition <num>	Set the reference position of the specified traces in the specified window
DISPlay:CCLEar	Clear the error message displayed in the status bar (at the lower right corner of the LCD displayer)
DISPlay:CLOCK <ON OFF>	Turn on/off clock display (upper right corner of the LCD displayer)
DISPlay:COLor<dnum>:BACK <num1>,<num2>,<num3>	Set /get screen background color
DISPlay:COLor<dnum>:GRATicule<gnum> <num1>,<num2>,<num3>	Set/get color marked by grid, outer edge line of Figure <gnum:1> and grid color of Figure <gnum:2>
DISPlay:COLor<dnum>:LIMit<lnum> <num1>,<num2>,<num3>	Set/get display color for the failed limit test results, bandwidth test results and wave test results (lnum: 1) and Limit color for the limit test results, bandwidth test results and wave test results (lnum: 2)
DISPlay:COLor<dnum>:RESet	Reset the display color of all items to the factory default state
DISPlay:COLor<dnum>:TRACe<tr>:DATA <num1>,<num2>,<num3>	Set/get the color of specified trace <tr>
DISPlay:COLor<dnum>:TRACe<tr>:MEMory <num1>,<num2>,<num3>	Set/get the color of the specified memory trace <tr>
DISPlay:ECHO:CLEar	Clear all contents displayed in the ECHO window
DISPlay:ECHO[:DATA] <string>	Strings to be displayed in the echo window
DISPlay:FSIGN <ON OFF>	Turn on/off the "failed (FAIL)" display of the LCD displayer when limit test, bandwidth test and wave test fail
DISPlay:IMAGe <NORMal INVert>	Set/get the display type of LCD displayer
DISPlay:MAXimize <ON OFF>	Turn on/off the zoom extent of the current window
DISPlay:SKEY[:STATe] <ON OFF>	Display/hide the side key menu
DISPlay:SPLit <char>	Window Layout
DISPlay:TABLE:POSition[:RECTangle]?	Read the display coordinate position ([0, 0] on upper left corner of the displayer) of the table area
DISPlay:TABLE[:STATe] <ON OFF>	Turn on/off table display
DISPlay:TABLE:TYPE <char>	Set/read the display table type (lower window of the LCD)
DISPlay:UPDate[:IMMediate]	When it displays Update Off (set by DISP:ENAB OFF), this command immediately performs a primary display update
DISPlay:WINDow<wnum>:ACTivate	Activate the specified window
DISPlay:WINDow<wnum>:LABel <ON OFF>	Turn on/off the grid label display of the specified window <wnum>
DISPlay:WINDow<wnum>:MAXimize <ON OFF>	Specify the zoom extent of active trace in the window <wnum>
DISPlay:WINDow<wnum>:TRACe<tr>:ANNotation:MARKer:POSition:X <num>	Set or read the Coordinate X position of the position displayed by the mark value
DISPlay:WINDow<wnum>:TRACe<tr>:ANNotation:MARKer:POSition:Y <num>	Set or read the Coordinate Y position of the position displayed by the mark value
DISPlay:WINDow<wnum>:X:SPACing <char>	(Read-Write) Targeting on the traces in the channels with segment sweep in the specified window <Wnum>, X-axis display

Annex Commands List

	type is set
DISPlay:WINDow<wnum>:Y[:SCALE]:DIVisions <num>	Set/get the grid numbers displayed on Y-axis
Format Commands	
FORMat:BORDER <char>	Some computers read data from the analyzer in the reverse order
FORMat[:DATA] <char>	Set the data format during data transmission
Hardcopy Commands	
HCOPY[:IMMEDIATE]	Print screen
Initiate Command	
INITiate:CONTInuous <boolean>	Set the analyzer to continuous trigger mode or manual trigger mode
INITiate<cnum>[:IMMEDIATE]	End the current sweep and immediately send a trigger signal to the specified channel
Memory Command	
MMEMemory:CATalog[:<char>]? [<folder>]	Return the file name list (separated by commas) of specified type under the specified folders
MMEMemory:CDIRectory <folder>	Change the path
MMEMemory:COPY <file1>,<file2>	When copy File 1 to File 2, it must specify an extension
MMEMemory:DELeTe <file>	When delete a file, it must specify an extension
MMEMemory:LOAD[:<char>] <file>	Load the specified file
MMEMemory:MDIRectory <folder>	Create new file folder
MMEMemory:MOVE <file1>,<file2>	Rename <file1> to <file2>. A file extension must be specified
MMEMemory:RDIRectory <folder>	Delete the specified folder
MMEMemory:STORE[:<char>] <file>	Store the specified file (.sta, .cal, .cst)
MMEMemory:CATalog <string>	Read the name and size of all files (including directories) under space occupation, available space and specified directory of memory device
MMEMemory:COPY <file1>,<file2>	Used to copy the specified file
MMEMemory:DELeTe <file>	Delete the specified file and directory
MMEMemory:LOAD:ASCFactor <file>	Recall the file (.csv) specified as a referential calibration factor table and power sensor A calibration factor table
MMEMemory:LOAD:BSCFactor <file>	Recall the file (.csv) specified as a referential calibration factor table and power sensor B calibration factor table
MMEMemory:LOAD:CKIT<Ckit> <file>	Recall the instrument state of a single channel from the specified register
MMEMemory:LOAD:LIMit <file>	From the specified limit table file from limit table of the active trace in active channels
MMEMemory:LOAD:PLOSs<pt> <file>	Recall the specified loss compensation table file, to be used as the loss compensation table for active channel and selected port
MMEMemory:LOAD:RLIMit <file>	Recall the specified fluctuation limit table file of the active channel
MMEMemory:LOAD:SEGMENT <file>	Recall the specified segment sweep list file
MMEMemory:LOAD[:STATE] <file>	Recall the specified instrument state file
MMEMemory:STORE:ASCFactor <file>	Store the reference calibration factor and calibration factor table

Annex Commands List

	of power sensor A to the specified file
MMEMory:STORe:BSCFactor <file>	Store the reference calibration factor and calibration factor table of power sensor B to the specified file
MMEMory:STORe:CKIT<Ckit> <file>	Store the calibration kit definition table to the file
MMEMory:STORe:FDATa <file>	Store the formative data array to CSV file
MMEMory:STORe:IMAGe <file>	Store the display image on the LCD screen to the file of bitmap format (.bmp) or portable network graphics format (.png)
MMEMory:STORe:LIMit <file>	Store the limit table of active traces in active channel to the specified format file
MMEMory:STORe:PLOSs<pt> <file>	Store the loss compensation table in active channel to the specified format file
MMEMory:STORe:RLIMit <file>	Store the fluctuation limit list table of active traces in active channel to the specified format file
MMEMory:STORe:SALL <ON OFF>	Set/get the settings to store all channel/trace, or only store the displayed channel/trace
MMEMory:STORe:SEGMENT <file>	Store the segment sweeo table of active channel to the specified format file
MMEMory:STORe:SNP[:DATA] <file>	Store the measurement data of active channel to the standard format file
MMEMory:STORe:SNP:FORMat <char>	Set/get the data format
MMEMory:STORe:SNP:TYPE:S1P <num>	When storing s1p data file, set/get the specified port
MMEMory:STORe:SNP:TYPE:S2P <num1>,<num2>	When storing s2p data file, set/get the specified port (2-ports)
MMEMory:STORe[:STATe] <file>	Store instrument state to the file
MMEMory:STORe:STYPe <char>	When store the instrument state to the file, select the content to be stored
Output Commands	
OUTPut[:STATe] <ON OFF>	Turn on or off RF source power output
Sense:Average Commands	
SENSe<cnum>:AVERAge:CLEAr	Clear and restart the averaging of the measurement data
SENSe<cnum>:AVERAge:COUNT <num>	Set the averaging times of measurement
SENSe<cnum>:AVERAge[:STATe] <ON OFF>	Turn on or off the track averaging function
Sense:Bandwidth Commands	
SENSe<cnum>:BANDwidth BWIDth[:RESolution] <num>	Set the bandwidth of the IF filter during the measurement. Keywords BAND and BWID are interchangeable
Sense:Correction Commands	
SENSe<cnum>:CORRection:CCHec k[:ACQuire] <char>[,char]	Read the "Confirmation Message" associated with the specified module, and write it to the memory
SENSe<cnum>:CORRection:CCHec k:DONE	End the confirmation check and set the electric calibration module to idle mode
SENSe<cnum>:CORRection:CCHec k:PARAMeter <Mname>	Specify a measurement for confirmation check
SENSe<cnum>:CORRection:COLLe	Specify the standard for the selected calibration kit for

Annex Commands List

ct[:ACQUIRE] <class>[,subclass]	measurement
SENSe<cnum>:CORREction:COLLe ct:APPLy	Apply the error item to the measurement, which can be selected via Calc:Par:Select
SENSe<cnum>:CORREction:COLLe ct:MEthod <char>	Set the calibration type
SENSe<cnum>:CORREction:COLLe ct:SAVE	Use the selected :MEthod to calculate the error item and apply it to the selected measurement (turn on the error correction function)
SENSe<cnum>:CORREction:EXTen sion:PORT<pnum>[:TIME] <num>	Set the extension value of the specified port It must use SENS:CORR:EXT ON command to turn on the port extension function simultaneously.
SENSe<cnum>:CORREction:EXTen sion:RECeiver<Rnum>[:TIME] <num>	Set the extension value of the specified receiver It must use SENS:CORR:EXT ON command to turn on port extension function simultaneously
SENSe<cnum>:CORREction:EXTen sion[::STATE] <ON OFF>	Turn on or off port extension
SENSe:CORREction:IMPedance:IN Put:MAGNitude <num>	Set system impedance value for analyzer
SENSe<cnum>:CORREction:INTerp olation[::STATE] <ON OFF>	Turn on or off the interpolation function of calibration
SENSe<cnum>:CORREction:ISOLat ion[::STATE] <ON OFF>	Turn on or off the isolation calibration function during full 2-port calibration
SENSe<cnum>:CORREction:RVELo city:COAX <num>	Set the factor coefficient for electric delay and port extension
SENSe:CORREction:SFORward[::ST ATE] <boolean>	When the calibration uses only a standard, set the direction of calibration
SENSe<cnum>:CORREction[::STATE] <ON OFF>	Set whether to correct the measurement data
SENSe:CORREction:TSTandards[::S TATE] <boolean>	Specify whether to use one or two standards to get the calibration data
SENSe<cnum>:CORREction:CLEar	Clear the error factor of calibration
SENSe<cnum>:CORREction:COEFFi cient[::DATA] <char>,<Cpt_A>,<Cpt_B>,<block>	Set or get the calibration factor data of the specified channel
SENSe<cnum>:CORREction:COEFFi cient:MEthod:ERESponse <num1>,<num2>	When using SENSe:CORREction:COEFFicient:DATA command to write the calibration coefficient array, this command sets the calibration type of channel <cnum> to enhanced response calibration
SENSe<cnum>:CORREction:COEFFi cient:MEthod[::RESPonse]:OPEN <num>	When using SENSe:CORREction:COEFFicient:DATA command to write the calibration coefficient array, this command sets the calibration type of channel <cnum> to open circuit response calibration of the specified port
SENSe<cnum>:CORREction:COEFFi cient:MEthod[::RESPonse]:SHORT <num>	When using SENSe:CORREction:COEFFicient:DATA data to write the calibration coefficient array, this command sets the calibration type of channel <cnum> to the short circuit response calibration of the specified port
SENSe<cnum>:CORREction:COEFFi cient:MEthod[::RESPonse]:THRU <num1>,<num2>	When using SENSe:CORREction:COEFFicient:DATA command to write the calibration coefficient array, this command sets the calibration type of channel <cnum> to through response calibration

Annex Commands List

SENSE<cnum>:CORREction:COEFFicient:METHod:SOLT1 <num>	When using SENSE:CORREction:COEFFicient:DATA command to write the calibration coefficient array, this command sets the calibration type of channel <cnum> to 1-port calibration
SENSE<cnum>:CORREction:COEFFicient:METHod:SOLT2 <num1>,<num2>	When using SENSE:CORREction:COEFFicient:DATA command to write the calibration coefficient array, this command sets the calibration type of channel <cnum> to full 2-port calibration
SENSE<cnum>:CORREction:COEFFicient:SAVE	Apply the calibration array data written by SENSE:CORREction:COEFFicient:DATA command to the specified channel measurement
SENSE<cnum>:CORREction:COLLe ct[:ACQuire]:ISOLation <num1>,<num2>	Measure the isolation calibration data from the specified stimulus port to the specified response port
SENSE<cnum>:CORREction:COLLe ct[:ACQuire]:LOAD <num>	Measure the calibration data for load standard of the specified port
SENSE<cnum>:CORREction:COLLe ct[:ACQuire]:OPEN <num>	Measure the calibration data for open circuit standard of the specified port
SENSE<cnum>:CORREction:COLLe ct[:ACQuire]:SHORT <num>	Measure the calibration data for short circuit standard of the specified port
SENSE<cnum>:CORREction:COLLe ct[:ACQuire]:SUBClass <num>	Set/get the standard subclass of calibration
SENSE<cnum>:CORREction:COLLe ct[:ACQuire]:THRU <num1>,<num2>	Measure the calibration data for through standard of two ports
SENSE<cnum>:CORREction:COLLe ct[:ACQuire]:TRLLine <num1>,<num2>	Perform the Line or Match measurement of TRL calibration of the selected calibration kit
SENSE<cnum>:CORREction:COLLe ct[:ACQuire]:TRLReflect <num>	Perform the reflection measurement of TRL calibration of the selected calibration kit
SENSE<cnum>:CORREction:COLLe ct[:ACQuire]:TRLThru <num1>,<num2>	Perform the through measurement of TRL calibration of the selected calibration kit
SENSE<cnum>:CORREction:COLLe ct:CLEar	Clear the calibration measurement data
SENSE<cnum>:CORREction:COLLe ct:METHod:ADAPter:REMOval <num>	Set the calibration type for the adaptor removal calibration of the specified port
SENSE<cnum>:CORREction:COLLe ct:METHod:ERESponse <num1>,<num2>	Set the calibration type for the enhanced response calibration between the 2 specified ports
SENSE<cnum>:CORREction:COLLe ct:METHod[:RESPonse]:OPEN <num>	Set the calibration type for the open circuit response calibration of the specified port
SENSE<cnum>:CORREction:COLLe ct:METHod[:RESPonse]:SHORT <num>	Set the calibration type for short circuit response calibration of the specified port
SENSE<cnum>:CORREction:COLLe ct:METHod[:RESPonse]:THRU <num1>,<num2>	Set the calibration type for the through response calibration of the specified port
SENSE<cnum>:CORREction:COLLe ct:METHod:SOLT1 <num>	Set the calibration type for 1-port calibration of the specified port
SENSE<cnum>:CORREction:COLLe	Set the calibration type for full 2-port calibration between 2

Annex Commands List

ct:MEtHod:SOLT2 <num1>,<num2>	specified ports
SENSe<cnum>:CORRection:COLLe ct:MEtHod:TRL2 <num1>,<num2>	Set the calibration type for the TRIL calibration of 2 specified ports
SENSe<cnum>:CORRection:COLLe ct:MEtHod:TYPE?	Read the selected calibration type for the selected channel <cnum>
SENSe<cnum>:CORRection:COLLe ct:PARTial:SAVE	This command (used for partial rewrite) can calculate calibration coefficient based on the calibration type selected by measured calibration data
SENSe<cnum>:CORRection:COLLe ct:SAVE	Use the selected :MEtHod to calculate error item and apply it to the selected measurement (turn on the error correction function)
SENSe<cnum>:CORRection:IMPed ance[:INPut][:MAGNitude] <num>	Set/get the system characteristics impedance (Z0) value
SENSe<cnum>:CORRection:PROP erty <ON OFF>	Turn on/off calibration property display
SENSe<cnum>:CORRection:RECEi ver<port>:COLLect:ACQuire <num>	Perform receiver calibration targeted on the measurement of selected port <port> of selected channel <cnum>
SENSe<cnum>:CORRection:RECEi ver<port>[:STATe] <ON OFF>	Turn on/off the error coefficient correction of receiver calibration
SENSe<cnum>:CORRection:RVELo city:COAX <num>	Set/get the velocity factor
SENSe<cnum>:CORRection:STATe <ON OFF>	Turn on/off error correction
SENSe<cnum>:CORRection:TYPE< tr>?	Targeted on active trace, read the error correction message currently being used
Sense:Correction:Collect:CKit Commands	
SENSe:CORRection:COLLect:CKIT: NAME <name>	Name the selected calibration kit
SENSe:CORRection:COLLect:CKIT: OLIST[class]?	Return the standard value assigned to the specified class
SENSe:CORRection:COLLect:CKIT: ORDeR<class> <std> [,<std>] [,<std>] [,<std>] [,<std>] [,<std>] [,<std>]	Set standard number for calibration class Not set or specify sequence for calibration standard
SENSe:CORRection:COLLect:CKIT: RESet <num>	Reset the specified calibration kit to default value
SENSe:CORRection:COLLect:CKIT[: SELection] <num>	Select (activate) a calibration kit, for implementing calibration or modifying standard
SENSe:CORRection:COLLect:CKIT: STANdard:C0 <num>	Set C0 value for the selected standard (first capacitance)
SENSe:CORRection:COLLect:CKIT: STANdard:C1 <num>	Set C1 value for the selected standard (secondary capacitance)
SENSe:CORRection:COLLect:CKIT: STANdard:C2 <num>	Set C2 value for the selected standard (tertiary capacitance)
SENSe:CORRection:COLLect:CKIT: STANdard:C3 <num>	Set C3 value for the selected standard (quartus capacitance)
SENSe:CORRection:COLLect:CKIT: STANdard:CHARacter <char>	Set the media type of the selected calibration standard

Annex Commands List

SENSE:CORRection:COLLect:CKIT:STANdard:DELay <num>	Set the electric delay value for the selected standard
SENSE:CORRection:COLLect:CKIT:STANdard:FMAX <num>	Set the max frequency value for the selected standard
SENSE:CORRection:COLLect:CKIT:STANdard:FMIN <num>	Set the min frequency for the selected standard
SENSE:CORRection:COLLect:CKIT:STANdard:IMPedance <num>	Set the characteristic impedance value for the selected standard
SENSE:CORRection:COLLect:CKIT:STANdard:L0 <num>	Set L0 value for the selected standard (first impedance value)
SENSE:CORRection:COLLect:CKIT:STANdard:L1 <num>	Set L1 value for the selected standard (secondary impedance value)
SENSE:CORRection:COLLect:CKIT:STANdard:L2 <num>	Set L2 value for the selected standard (tertiary impedance value)
SENSE:CORRection:COLLect:CKIT:STANdard:L3 <num>	Set L3 for the selected standard (quartus impedance value)
SENSE:CORRection:COLLect:CKIT:STANdard:LABel <name>	Set label for the selected standard. Label is used to reminder the user of connecting the specified standard
SENSE:CORRection:COLLect:CKIT:STANdard:LOSS <num>	Set the insertion loss of the selected standard
SENSE:CORRection:COLLect:CKIT:STANdard:[SELECT] <num>	Select the calibration standard, the subsequent "CKIT" command for modifying the standard must use this standard Use SENS:CORR:COLL:CKIT:SEL to select calibration kit
SENSE:CORRection:COLLect:CKIT:STANdard:TYPE <char>	Set the type of the selected standard
SENSe<cnum>:CORRection:COLLect:CKIT:LABel <name>	Name the selected calibration kit
SENSe<cnum>:CORRection:COLLect:CKIT:ORDer:LOAD <Cpt>,<num>	Specify standard for load measurement
SENSe<cnum>:CORRection:COLLect:CKIT:ORDer:OPEN <Cpt>,<num>	Specify standard for port Cpt open circuit measurement
SENSe<cnum>:CORRection:COLLect:CKIT:ORDer:SELEct <num>	Set/Get the standard subclass of calibration
SENSe<cnum>:CORRection:COLLect:CKIT:ORDer:SHORt <Cpt>,<num>	Specify standard for port Cpt short circuit measurement
SENSe<cnum>:CORRection:COLLect:CKIT:ORDer:THRU <Cpt1_A>,<Cpt_B>,<num>	Specify standard for transmission measurement
SENSe<cnum>:CORRection:COLLect:CKIT:ORDer:TRLLine <Cpt1_A>,<Cpt_B>,<num>	Specify standard for line measurement of TRL calibration
SENSe<cnum>:CORRection:COLLect:CKIT:ORDer:TRLReflect <num>	Specify standard for reflection measurement of TRL calibration
SENSe<cnum>:CORRection:COLLect:CKIT:ORDer:TRLThru <Cpt1_A>,<Cpt_B>,<num>	Specify standard for through measurement of TRL calibration
SENSe<cnum>:CORRection:COLLect:CKIT:RESEt	Reset the calibration kit to factory settings
SENSe<cnum>:CORRection:COLLect:CKIT:SEL	Select calibration kit or get the index of the calibration kit

Annex Commands List

ct:CKIT[:SElect] <num>	currently selected
SENSE<cnum>:CORRection:COLLe ct:CKIT:STAN<std>:ARBitrary <num>	Set or get arbitrarily impedance of standard (std)
SENSE<cnum>:CORRection:COLLe ct:CKIT:STAN<std>:C0 <num>	Set or get C0 of standard (std)
SENSE<cnum>:CORRection:COLLe ct:CKIT:STAN<std>:C1 <num>	Set or get C0 of standard (std)
SENSE<cnum>:CORRection:COLLe ct:CKIT:STAN<std>:C2 <num>	Set or get C0 of standard (std)
SENSE<cnum>:CORRection:COLLe ct:CKIT:STAN<std>:C3 <num>	Set or get C0 of standard (std)
SENSE<cnum>:CORRection:COLLe ct:CKIT:STAN<std>:CHARacter <char>	Set or get media type of standard (std)
SENSE<cnum>:CORRection:COLLe ct:CKIT:STAN<std>:DELay <num>	Set or get offset time delay of standard (std)
SENSE<cnum>:CORRection:COLLe ct:CKIT:STAN<std>:FMAXimum <num>	Set or get max frequency of standard (std)
SENSE<cnum>:CORRection:COLLe ct:CKIT:STAN<std>:FMINimum <num>	Set or get min. frequency of standard (std)
SENSE<cnum>:CORRection:COLLe ct:CKIT:STAN<std>:L0 <num>	Set or get L0 of standard (std)
SENSE<cnum>:CORRection:COLLe ct:CKIT:STAN<std>:L1 <num>	Set or get L1 of standard (std)
SENSE<cnum>:CORRection:COLLe ct:CKIT:STAN<std>:L2 <num>	Set or get L2 of standard (std)
SENSE<cnum>:CORRection:COLLe ct:CKIT:STAN<std>:L3 <num>	Set or get L3 of standard (std)
SENSE<cnum>:CORRection:COLLe ct:CKIT:STAN<std>:LABel <name>	Set or get the name of standard (std)
SENSE<cnum>:CORRection:COLLe ct:CKIT:STAN<std>:LOSS <num>	Set or get offset loss value of standard (std)
SENSE<cnum>:CORRection:COLLe ct:CKIT:STAN<std>:TYPE <char>	Set or get standard type of standard (std)
SENSE<cnum>:CORRection:COLLe ct:CKIT:STAN<std>:Z0 <num>	Set or get offset Z0 value of standard (std)
SENSE<cnum>:CORRection:COLLe ct:CKIT:TRLOption:IMPedance <char>	Set or get reference impedance during TRL calibration
SENSE<cnum>:CORRection:COLLe ct:CKIT:TRLOption:RPLane <char>	Set/get the calculation method of the calibration plane
Sense:Correction:CSET command (Note: Commands of this command block are not provided temporarily)	
SENSE<cnum>:CORRection:CSET: CATalog?	Return the string of calibration set GUID list separated by comma

Annex Commands List

SENSe<cnum>:CORRection:CSET:DELEte <string>	Delete a calibration set from calibration set
SENSe<cnum>:CORRection:CSET:DESCRiption <string>	Set or return the descriptive string of the selected calibration set
SENSe<cnum>:CORRection:CSET:GUID <string>	Select the calibration set via GUID and apply to the specified channel
SENSe<cnum>:CORRection:CSET[:SELEct] <char>	Reload the correction data file from the memory
SENSe<cnum>:CORRection:CSET:SAVE <char>	Write the correction data file to memory or read the correction data file last stored
Sense:Correction:Collect:Guided command (Note: Commands of this command block are not provided temporarily)	
SENSe<cnum>:CORRection:COLLe ct:GUIDed:ACQuire <std>	Initialize the measurement of the specified calibration standard It will not function on the standards not needing to perform this command
SENSe<cnum>:CORRection:COLLe ct:GUIDed:CKIT:PORT<pnum>:CATalog?	Return the list of valid calibration kit of each port (separated by comma)
SENSe<cnum>:CORRection:COLLe ct:GUIDed:CKIT:PORT<pnum>[:SELEct] <kit>	Specify the calibration kit used by each port during guided calibration
SENSe<cnum>:CORRection:COLLe ct:GUIDed:CONNEct:CATalog?	Return a list of valid connector based on the description of the available calibration kit connector
SENSe<cnum>:CORRection:COLLe ct:GUIDed:CONNEct:PORT<pnum>[:SELEct] <conn>	Specify the connector type for each port during guided calibration
SENSe<cnum>:CORRection:COLLe ct:GUIDed:DESCRiption? <step>	Return the connection description of the specified calibration step
SENSe<cnum>:CORRection:COLLe ct:GUIDed:INITiate	Initiate a guided calibration via creating a new calibration kit
SENSe<cnum>:CORRection:COLLe ct:GUIDed:METHod <char>	Select an available algorithm for guided calibration
SENSe<cnum>:CORRection:COLLe ct:GUIDed:SAVE	Calculate the error correction item, turn on the calibration and store the calibration to the calibration set, thus ending the guided calibration
SENSe<cnum>:CORRection:COLLe ct:GUIDed:STEPs?	Return the measurement step number required by the current guided calibration
Sense:Couple Commands	
SENSe<cnum>:COUPLe <ALL NONE>	Set sweep mode to simultaneous or alternative sweep
Sense:Frequency Commands	
SENSe<cnum>:FREQUency:CENTe r <num>	Set the center frequency of analyzer
SENSe<cnum>:FREQUency[:CW :FIXed] <num>	Set continuous wave (fixed) frequency
SENSe<cnum>:FREQUency:SPAN <num>	Set the frequency span of analyzer
SENSe<cnum>:FREQUency:START	Set the start frequency of analyzer

Annex Commands List

<num>	
SENSE<cnum>:FREQUENCY:STOP <num>	Set the stop frequency of analyzer
SENSE<cnum>:FREQUENCY:DATA?	Equivalent command, inquire the incentive value of all measurement points
SENSE<cnum>:X[:VALUES]?	
Sense:Power Commands	
SENSE<cnum>:POWER:ATTENUATION <recvr>,<num>	Set the attenuation value of receiver (Determined by the instrument configuration)
Sense:Roscillator command	
SENSE:ROSCILLATOR:SOURCE?	Read the connection status of reference signal
Sense:Segment Commands	
SENSE<cnum>:SEGMENT<snum>:ADD	Add a segment
SENSE<cnum>:SEGMENT<snum>:BWIDTH[:RESOLUTION] <num>	Set the IFBW of the specified segment
SENSE<cnum>:SEGMENT:BWIDTH[:RESOLUTION]:CONTROL <ON OFF>	Specify whether it can individually set the IFBW of each segment
SENSE<cnum>:SEGMENT:COUNT?	Inquire the segment quantity existing in the specified channel
SENSE<cnum>:SEGMENT<snum>:DELETE	Select the specified sweep segment
SENSE<cnum>:SEGMENT:DELETE:ALL	Delete all sweep segment
SENSE<cnum>:SEGMENT<snum>:FREQUENCY:CENTER <num>	Set the center frequency for the specified segment, and the start and stop frequency will vary with it but the frequency span remains unchanged
SENSE<cnum>:SEGMENT<snum>:FREQUENCY:SPAN <num>	Set the frequency span for the specified segment. The center frequency of segment remains unchanged while the start and stop frequency vary with it
SENSE<cnum>:SEGMENT<snum>:FREQUENCY:START <num>	Set the start frequency for the specified sweep segment
SENSE<cnum>:SEGMENT<snum>:FREQUENCY:STOP <num>	Set the stop frequency for the specified sweep segment
SENSE<cnum>:SEGMENT<snum>:POWER[:PORT][:LEVEL] <num>	Set port power level for the specified sweep point
SENSE<cnum>:SEGMENT:POWER[:LEVEL]:CONTROL <ON OFF>	Whether it can independently set the power level of each segment
SENSE<cnum>:SEGMENT<snum>[:STATE] <ON OFF>	Turn on or off the sweep segment
SENSE<cnum>:SEGMENT<snum>:SWEPT:POINTS <num>	Set sweep point for the specified sweep segment
SENSE<cnum>:SEGMENT<snum>:SWEPT:TIME <num>	Set the sweep time of the specified sweep segment of analyzer
SENSE<cnum>:SEGMENT:SWEPT:TIME:CONTROL <ON OFF>	Specify whether it can independently set the sweep time of each segment
SENSE<cnum>:SEGMENT:DATA <block>	Set or get the segment sweep point of the specified channel
Sense:Sweep Commands	

Annex Commands List

SENSE<num>:SWEep:DWELI<num>	Set the dwell time between two sweep points
SENSE<num>:SWEep:DWELI:AUTO <ON OFF>	Specify whether automatically calculate and set the possible minimum dwell time
SENSE<num>:SWEep:GENeration<char>	Set sweep mode to stepped or analog mode
SENSE<num>:SWEep:GROups:COUNT <num>	Set the group trigger times for the specified channel
SENSE<num>:SWEep:MODE<char>	Set trigger mode for the specified channel
SENSE<num>:SWEep:POINts<num>	Set number of measurement points
SENSE<num>:SWEep:SRCPort <1 2>	Set the source port during non S-Parameter measurement, without affecting measurement of S-Parameter
SENSE<num>:SWEep:TIME<num>	Set the sweep time required for primary sweep by analyzer
SENSE<num>:SWEep:TIME:AUTO <ON OFF>	Turn on or off automatic sweep time calculation function
SENSE<num>:SWEep:TRIGger:POINt <ON OFF>	Set the trigger mode of the specified channel: measure a point or all points on channel upon each trigger
SENSE<num>:SWEep:TYPE<char>	Set the sweep type of analyzer
Service Commands	
SERVICE:CHANnel<num>:TRACE:ACTIVE?	Read the index of active trace of selected channel <num>
SERVICE:WINDow<wnum>:TRACE:ACTIVE?	Read the number of active traces in the specified window <wnum>
SERVICE:CHANnel:ACTIVE?	Read the active channel number
SERVICE:WINDow:ACTIVE?	Read the active window number
SERVICE:CHANnel:COUNT?	Read the upper limit channel number
SERVICE:WINDow:COUNT?	Read the upper limit of window number
SERVICE:CHANnel:TRACE:COUNT?	Read the upper limit of each channel trace number
SERVICE:WINDow:TRACE:COUNT?	Read the upper limit of each window trace number
SERVICE:PORT:COUNT?	Read the number of ports
SERVICE:SREvision?	Read the system technical specification version
SERVICE:SWEep:FREQuency:MAXimum?	Read the upper limit of measurement frequency
SERVICE:SWEep:FREQuency:MINimum?	Read the lower limit of measurement frequency
SERVICE:SWEep:POINts?	Read the upper limit of measurement point of the current configuration
Source Commands	
SOURCE<num>:POWER<port>:ATTenuation <num>	Set the attenuation values for the selected channel. If the port is coupled, then the attenuation value of a port varies with the changes of that of other ports
SOURCE<num>:POWER<port>:ATTenuation:AUTO <ON OFF>	Turn on or off automatic attenuation

Annex Commands List

SOURce<cnum>:POWER:CENTer<num>	Set the center power of power sweep
SOURce<cnum>:POWER:COUPlE<ON OFF>	Turn on or off port coupling function
SOURce<cnum>:POWER:DETEctor<INTernal EXTernal>	Set the loop circuit of source fixed-amplitude to internal or external detection
SOURce<cnum>:POWER<port>[:LEVel][:IMMediate][:AMPLitude] <num>	Set the radio frequency output level
SOURce<cnum>:POWER[:LEVel]:SLOPe <int>	Set the radio frequency slope value
SOURce<cnum>:POWER[:LEVel]:SLOPe:STATe <ON OFF>	Turn on or off power slope
SOURce<cnum>:POWER:SPAN<num>	Set the frequency bandwidth during power sweep
SOURce<cnum>:POWER:STARt<num>	Set the start power during power sweep
SOURce<cnum>:POWER:STOP<num>	Set the stop power during power sweep
SOURce<cnum>:POWER[:LEVel]:SLOPe[:DATA] <int>	Set radio frequency port output power
SOURce<cnum>:POWER:PORT:COUPlE <ON OFF>	Turn on or off port coupling function
SOURce<cnum>:POWER:PORT<port>[:LEVel][:IMMediate][:AMPLitude] <num>	Get/set the power level of the specified port
Source:Power:Correction Commands (Note: Commands of this command block are not provided temporarily)	
SOURce<cnum>:POWER<port>:CORRection:COLLect:ABORt	Abort the source power calibration sweep in operation
SOURce<cnum>:POWER<port>:CORRection:COLLect[:ACQuire] <char>	Initialize the source power calibration sweep by using the power meter sensor connected to the specified power meter channel (A or B)
SOURce<cnum>:POWER<port>:CORRection:COLLect:AVERAge[:COUnt] <num>	Set the number of power reads (i.e. average factor) of each frequency point during source power calibration sweep
SOURce<cnum>:POWER:CORRection:COLLect:FCHeck[:STATe] <ON OFF>	Set to turn on or off the frequency check during source power calibration sweep
SOURce<cnum>:POWER<port>:CORRection:COLLect:METhod <char>	Select the source power calibration method It currently only supports 'power meter'
SOURce<cnum>:POWER<port>:CORRection:COLLect:SAVE	Apply the correction data after completing source power calibration sweep
SOURce<cnum>:POWER:CORRection:COLLect:<pmChan>SENsor[:FRANge] <num1>,<num2>	Specify the frequency range, where the power sensor connected to the specified channel (A and B) of power meter can be used (min and max frequency)
SOURce<cnum>:POWER:CORRection:COLLect:<pmChan>SENsor:RCF actor <num>	Set the reference calibration factor for the power sensors connected to power meter Channel A or B

Annex Commands List

SOURce<cnum>:POWER:CORRecti on:COLLect:TABLE:DATA <data>	Read and write the selected table data
SOURce<cnum>:POWER:CORRecti on:COLLect:TABLE:FREQUency <data>	Read and write frequency data from the selected table (power sensor table or loss difference compensation table)
SOURce<cnum>:POWER:CORRecti on:COLLect:TABLE:LOSS[:STATe] <ON OFF>	Set whether use loss compensation table to correct the power meter reads during source power sweep calibration
SOURce<cnum>:POWER:CORRecti on:COLLect:TABLE:POINts?	Return the segment number of the currently selected table
SOURce<cnum>:POWER:CORRecti on:COLLect:TABLE[:SElect] <char>	Select the data to read and write data (calibration factor table of power sensor, or loss difference compensation table)
SOURce<cnum>:POWER<port>:CO RRection:DATA <data>	Read and write source power calibration data
SOURce<cnum>:POWER<port>:CO RRection:LEVel <num>	Specify the power level output to the reference surface (DUT input or output)
SOURce<cnum>:POWER<port>:CO RRection[:STATe] <ON OFF>	Turn on or off the source power correction function of the specified port on the specified channel
SOURce<cnum>:POWER:PORT<por t>:CORRection:COLLect[:ACQuire] <char>	Initialize the source power calibration sweep by using the power meter sensor connected to the specified power meter channel (A or B)
SOURce<cnum>:POWER:PORT<por t>:CORRection:COLLect:AVERAge[: COUNT] <int>	Turn on or off the source power correction function of the specified port on the specified channel
SOURce<cnum>:POWER:PORT<por t>:CORRection:COLLect:TABLE:LO SS:DATA <data>	Set/get the loss compensation table
SOURce<cnum>:POWER:PORT<por t>:CORRection:COLLect:TABLE:LO SS[:STATe] <ON OFF>	Set whether use loss compensation table to correct the power meter reads during source power sweep calibration
SOURce<cnum>:POWER:PORT<por t>:CORRection:DATA <data>	Read and write source power calibration data
SOURce<cnum>:POWER:PORT<por t>:CORRection[:STATe] <ON OFF>	Turn on or off the source power correction function of the specified port on the specified channel
SOURce:POWER:PORT:CORRection :COLLect:ASEnsor:RCFactor <num>	Set/get the reference calibration factor (50MHz calibration factor) of power meter A
SOURce:POWER:PORT:CORRection :COLLect:BEsEnSor:RCFactor <num>	Set/get the reference calibration factor (50MHz calibration factor) of power meter B.
SOURce<cnum>:POWER:PORT<por t>:CORRection:COLLect:NTOLeran ce <num> (Not Achievable Temporarily)	Set/get the power calibration data tolerance value of each measurement point on the specified channel and port
SOURce:POWER:PORT:CORRection :COLLect:TABLE:ASEnsor:DATA <data>	Set/get the calibration factor table of power sensor A
SOURce:POWER:PORT:CORRection :COLLect:TABLE:BEsEnSor:DATA <data>	Set/get the calibration factor table of power sensor B
Status Command Keyword	

Annex Commands List

:CONDition?	Real-time monitoring mode. But it also means a certain status has been produced, but might be cleared away before reading. Read this register, it returns a weighted value in 16 decimal
:ENABle <bit>	Use a service request (SRQ) method to monitor Enable register bits
:ENABle?	Read the Enable register to determine the enabled bits
[:EVENT]?	Only for query - Default keyword of most registers
:MAP <bit>,<error>	Association a bit of User register to an error bit
:NTRansition <bits>	Write-read backward transition register, used to set the transition from True to False
:NTRansition?	Inquire the register, to view whether backward transition occurs
:PTRansition <bits>	Write-read forward transition register, used to set the transition from False to True
:PTRansition?	Inquire the register, to view whether forward transition occurs
Status Byte Register	
*CLS	Clear all 'Event register and SCPI error/event queue. But the corresponding Enable register will not be affected
*STB?	Read the value of analyzer status byte. The byte value remains unchanged after reading
*SRE?	Read the current status of Service Request Enable Register
*SRE <num>	Set the bit value of Service Request Enable Register. The current setting of SRE register is stored to the non-volatile memory. Use *SRE 0 command to clear enable
Status Register Commands	
STATus:QUEStionable:<keyword>	Summarize the measurement data status
STATus:QUEStionable:INTegrity <keyword>	Summarize the status of Integrity register
STATus:QUEStionable:INTegrity:HA RDware<keyword>	Monitor the hardware failure
STATus:QUEStionable:INTegrity:ME ASurement<n> <keyword>	Monitor the time difference between changing channel setting and preparing data for inquire the output
STATus:QUEStionable:LIMit<n> <keyword>	Monitor and summarize the limit line failure status
STATus:QUEStionable:DEFine<key word>	Summarize the status of Questionable:Define:User<1 2 3> event register
Standard Event Status Register	Monitor "standard" event generated by analyzer
STATus:OPERation<keyword>	Summarize the status of Averaging and Operation:Define:User<1 2 3> event registers
STATus:OPERation:AVERaging<n> <keyword>	Monitor and summarize the averaging operation status of Trace 1 to 512
STATus:OPERation:DEFine<keywor d>	Summarize the status of OPERATION:Define:User<1 2 3> event register
STATus:OPERation:DEFine:USER< 1 2 3><keyword>	Monitor the user definition and the event status mapping in one of OPER:DEF:USER registers
STATus:OPERation:DEVice<keywor d>	Summarize the status of OPERATION:DEVice event register
STATus:OPERation:CONDition	Read the value of the operation status condition register

Annex Commands List

STATus:OPERation:ENABle	Set/get the value of the operation status startup register
STATus:OPERation:EVENT	Read the value of the operation status event register
STATus:OPERation:NTRansition	Set/get the value of the negative transition filter of the operation status register
STATus:OPERation:PTRansition	(Read-Write)) Set/get the value of the positive transition filter of the operation status register
STATus:PRESet	Initialization
STATus:QUESTionable:BLIMit:CHANnel<cnum>:CONDition	Read the value of the questionable bandwidth limit channel status condition register of specified channel
STATus:QUESTionable:BLIMit:CHANnel<cnum>:EChannel:CONDition	Read the value of the questionable bandwidth limit channel status condition register of specified channel
STATus:QUESTionable:BLIMit:CHANnel<cnum>:EChannel:ENABle	Set/get the value of the questionable bandwidth limit channel additional status enabling register of specified channel
STATus:QUESTionable:BLIMit:CHANnel<cnum>:EChannel:EVENT	Read the value of the “questionable bandwidth limit channel additional status event register” of specified channel
STATus:QUESTionable:BLIMit:CHANnel<cnum>:EChannel:NTRansition	Set/get the value of the negative transition filter of the “questionable bandwidth limit channel additional status register” of specified channel
STATus:QUESTionable:BLIMit:CHANnel<cnum>:EChannel:PTRansition	Set/get the value of the positive transition filter of the “questionable bandwidth limit channel additional status register” of specified channel
STATus:QUESTionable:BLIMit:CHANnel<cnum>:ENABle	Set/get the value of the “questionable bandwidth limit channel status enabling register” of specified channel
STATus:QUESTionable:BLIMit:CHANnel<cnum>:EVENT	Read the value of the “questionable bandwidth limit channel status event register” of specified channel
STATus:QUESTionable:BLIMit:CHANnel<cnum>:NTRansition	Set/get the value of the positive transition filter of the “limited channel status register with questionable bandwidth” of specified channel
STATus:QUESTionable:BLIMit:CHANnel<cnum>:PTRansition	Set/get the value of the positive transition filter of the “limited channel status register with questionable bandwidth” of specified channel
STATus:QUESTionable:BLIMit:CONDition	Read the value of the questionable bandwidth additional status condition register
STATus:QUESTionable:BLIMit:ELIMit:CONDition	Read the value of the questionable bandwidth additional status condition register
STATus:QUESTionable:BLIMit:ELIMit:ENABle	Set/get the value of the questionable bandwidth limit additional status enabling register
STATus:QUESTionable:BLIMit:ELIMit:EVENT	Read the value of the questionable bandwidth additional status event register
STATus:QUESTionable:BLIMit:ELIMit:NTRansition	Set/get the value of the negative transition filter of the questionable bandwidth limit additional status register
STATus:QUESTionable:BLIMit:ELIMit:PTRansition	Set/get the value of the positive transition filter of the questionable bandwidth limit additional status register
STATus:QUESTionable:BLIMit:ENABle	Set/get the value of the questionable bandwidth limit status enabling register
STATus:QUESTionable:BLIMit:EVENT	Read the value of the questionable bandwidth limit status event register
STATus:QUESTionable:BLIMit:NTRansition	Set/get the value of the negative transition filter of the questionable bandwidth limit status register

Annex Commands List

STATus:QUEStionable:BLIMit:PTRansition	Set/get the value of the positive transition filter of the questionable bandwidth limit status register
STATus:QUEStionable:CONDition	Read the value of the questionable status condition register
STATus:QUEStionable:ENABle	Set/get the value of the questionable status enabling register
STATus:QUEStionable:EVENT	Read the value of the questionable status event register
STATus:QUEStionable:LIMit:CHANnel<cnum>:CONDition	Read the value of the questionable limit channel status condition register of specified channel
STATus:QUEStionable:LIMit:CHANnel<cnum>:ECHANnel:CONDition	Read the value of the questionable limit channel status condition register of specified channel
STATus:QUEStionable:LIMit:CHANnel<cnum>:ECHANnel:ENABle	Set/get the value of the questionable limit channel additional status enabling register of specified channel
STATus:QUEStionable:LIMit:CHANnel<cnum>:ECHANnel:EVENT	Read the value of the “questionable limit channel additional status event register” of specified channel
STATus:QUEStionable:LIMit:CHANnel<cnum>:ECHANnel:NTRansition	Set/get the value of the negative transition filter of the “questionable limit channel additional status register” of specified channel
STATus:QUEStionable:LIMit:CHANnel<cnum>:ECHANnel:PTRansition	Set/get the value of the positive transition filter of the “questionable bandwidth limit channel additional status register” of specified channel
STATus:QUEStionable:LIMit:CHANnel<cnum>:ENABle	Set/get the value of the “questionable limit channel status enabling register” of specified channel
STATus:QUEStionable:LIMit:CHANnel<cnum>:EVENT	Read the value of the “questionable limit channel status event register” of specified channel
STATus:QUEStionable:LIMit:CHANnel<cnum>:NTRansition	Set/get the value of the positive transition filter of the “questionable limit channel status register” of specified channel
STATus:QUEStionable:LIMit:CHANnel<cnum>:PTRansition	Set/get the value of the positive transition filter of the “questionable limit channel status register” of specified channel
STATus:QUEStionable:LIMit:CONDition	Read the value of the questionable limit additional status condition register
STATus:QUEStionable:LIMit:ELIMit:CONDition	Read the value of the questionable limit additional status condition register
STATus:QUEStionable:LIMit:ELIMit:ENABle	Set/get the value of the questionable limit additional status enabling register
STATus:QUEStionable:LIMit:ELIMit:EVENT	Read the value of the questionable limit additional status event register
STATus:QUEStionable:LIMit:ELIMit:NTRansition	Set/get the value of the negative transition filter of the questionable limit additional status register
STATus:QUEStionable:LIMit:ELIMit:PTRansition	Set/get the value of the positive transition filter of the questionable bandwidth limit additional status register
STATus:QUEStionable:LIMit:ENABle	Set/get the value of the questionable limit status enabling register
STATus:QUEStionable:LIMit:EVENT	Read the value of the questionable limit status event register
STATus:QUEStionable:LIMit:NTRansition	Set/get the value of the negative transition filter of the questionable limit status register
STATus:QUEStionable:LIMit:PTRansition	Set/get the value of the positive transition filter of the questionable limit status register
STATus:QUEStionable:NTRansition	Set/get the value of the negative transition filter of the questionable status register

Annex Commands List

STATus:QUEStionable:PTRansition	Set/get the value of the positive transition filter of the questionable status register
STATus:QUEStionable:RLIMit:CHANnel<cnum>:CONDition	Read the value of the questionable wave limit channel status condition register of specified channel
STATus:QUEStionable:RLIMit:CHANnel<cnum>:EChannel:CONDition	Read the value of the questionable wave limit channel status condition register of specified channel
STATus:QUEStionable:RLIMit:CHANnel<cnum>:EChannel:ENABLE	Set/get the value of the questionable wave limit channel additional status enabling register of specified channel
STATus:QUEStionable:RLIMit:CHANnel<cnum>:EChannel:EVENT	Read the value of the “questionable wave limit channel additional status event register” of specified channel
STATus:QUEStionable:RLIMit:CHANnel<cnum>:EChannel:NTRansition	Set/get the value of the negative transition filter of the “questionable wave channel additional status register” of specified channel
STATus:QUEStionable:RLIMit:CHANnel<cnum>:EChannel:PTRansition	Set/get the value of the positive transition filter of the “questionable wave limit channel additional status register” of specified channel
STATus:QUEStionable:RLIMit:CHANnel<cnum>:ENABLE	Set/get the value of the “questionable wave limit channel status enabling register” of specified channel
STATus:QUEStionable:RLIMit:CHANnel<cnum>:EVENT	Read the value of the “questionable wave limit channel status event register” of specified channel
STATus:QUEStionable:BLIMit:CHANnel<cnum>:NTRansition	Set/get the value of the positive transition filter of the “questionable wave limit channel status register” of specified channel
STATus:QUEStionable:RLIMit:CHANnel<cnum>:PTRansition	Set/get the value of the positive transition filter of the “questionable wave limit channel status register” of specified channel
STATus:QUEStionable:RLIMit:CONDition	Read the value of the questionable wave additional status condition register
STATus:QUEStionable:RLIMit:ELIMit:CONDition	Read the value of the questionable wave additional status condition register
STATus:QUEStionable:BLIMit:ELIMit:ENABLE	Set/get the value of the questionable wave limit additional status enabling register
STATus:QUEStionable:RLIMit:ELIMit:EVENT	Read the value of the questionable wave limit additional status event register
STATus:QUEStionable:RLIMit:ELIMit:NTRansition	Set/get the value of the negative transition filter of the questionable wave limit additional status register
STATus:QUEStionable:RLIMit:ELIMit:PTRansition	Set/get the value of the positive transition filter of the questionable wave limit additional status register
STATus:QUEStionable:RLIMit:ENABLE	Set/get the value of the questionable wave limit status enabling register
STATus:QUEStionable:RLIMit:EVENT	Read the value of the questionable bandwidth limit status event register
STATus:QUEStionable:RLIMit:NTRansition	Set/get the value of the negative transition filter of the questionable wave limit status register
STATus:QUEStionable:RLIMit:PTRansition	Set/get the value of the positive transition filter of the questionable wave limit status register
System Commands	
SYSTem:COMMunicate:GPIB:PMETer:ADDRess <num> (Not supported)	Specify the power meter GPIB address during source power calibration

Annex Commands List

SYSTem:CORRection:WIZard <char>	Run calibration guidance or dialogue box of installing calibration kit
SYSTem:ERRor?	Return the next error on the error queue
SYSTem:ERRor:COUNT?	Return the error number in the error list
SYSTem:PRESet	Reset the system
SYSTem:BEEPer:COMPLete:IMMediate	Beep to notify the operation is completed
SYSTem:BEEPer:COMPLete:STATe <ON OFF>	Turn on/off or return the buzzer status notifying the operation is completed
SYSTem:BEEPer:WARning:IMMediate	Beep to notify warning/limit test result
SYSTem:BEEPer:WARning:STATe <ON OFF>	Turn on/off or return the buzzer status notifying warning/limit test result
SYSTem:CORRection[:STATe] <ON OFF>	Turn on/off or return system correction status
SYSTem:DATE <data>	Set/get the data of built-in clock
SYSTem:ERRor <Not Supported Temporarily>	Read the earliest stored error in the error list of the error queue
SYSTem:KLOCK:KBD <ON OFF>	Set/get whether to lock the operation on front panel (key and knob) and keyboard
SYSTem:KLOCK:MOUSE <ON OFF>	Set/get whether to lock the operation on mouse and touch screen
SYSTem:POFF	Turn off the device
SYSTem:SECurity:LEVel <char>	Set/get the security level
SYSTem:SERVice	Read whether the instrument is in service mode
SYSTem:TIME <data>	Set/get the time of built-in clock
SYSTem:UPReset	Preset the instrument via user setting
Trigger Commands	
TRIGger[:SEQuence]:LEVel <char>	Set to trigger signal at high level or low level (edge triggering mode not supported at present).
TRIGger[:SEQuence]:SCOPE <char>	Set trigger range, trigger all channels or the current channel.
TRIGger[:SEQuence]:SOURce <char>	Set to trigger the signal source with sweep. This command is a superset of the INITiate:CONTinuous command, and the INITiate command cannot set the source to external mode
TRIGger:OUTPut:POLarity <char>	Set/get the polarity of the pulse generated by external trigger output port
TRIGger:OUTPut:POSition <char>	Set/get the position of external trigger output port
TRIGger:OUTPut:STATe <ON OFF>	Set/get the status of external trigger output port
TRIGger[:SEQuence]:AVERage <ON OFF>	The sweep function must be set to ON when the averaging trigger function is ON
TRIGger[:SEQuence]:EXTernal:DELay <value>	Set/get the time required from receiving trigger to measurement starting when the trigger source is external
TRIGger[:SEQuence]:EXTernal:LLATency[:STATe] <ON OFF> <Not Achievable Temporarily>	Turn on/off or return low time delay external trigger status

Annex Commands List

TRIGger[:SEQuence]:EXTernal:SLO Pe <char>	Set/get the polarity of the input port of external trigger
TRIGger[:SEQuence]:IMMEDIATE	This command can immediately generate a trigger and execute a measurement regardless of the trigger mode setting
TRIGger[:SEQuence]:POINT <ON OFF>	Turns ON/OFF or returns to the state of the single-point trigger status
TRIGger[:SEQuence]:SINGLE	This command can immediately generate a trigger and execute a measurement regardless of the trigger mode setting
TRIGger[:SEQuence]:SOURce <char>	Set/get trigger source