

Double-Ridged Horn Antenna

Features:

- Ultra-Wide Band
- High Gain
- Stable Performance

Specification Details

Electrical Specifications

Parameter	Specification
Frequency Range	0.8-25.0 GHz
VSWR (Max)	2.5 @0.8-2GHz 2.0 @2-25GHz
Gain (Avg)	10 dB
Polarization	Linear
Average Power (Max)	50 W

Mechanical Specifications:

Parameter	Specification
Connector Type	SMA Female
Material	Aluminum
Inside Finish	Anodic Oxidation
Outside Finish	Anticorrosion grey paint
Weight	1.8 kg
Operating Temp	-40°C-+70°C
Storage Temp	-40°C-+85°C

Mechanical Outline (Unit:mm)

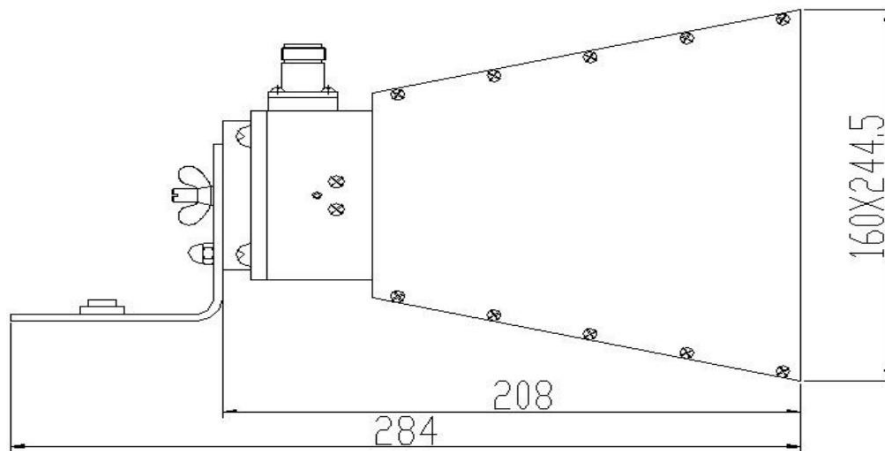



Simulation: VSWR

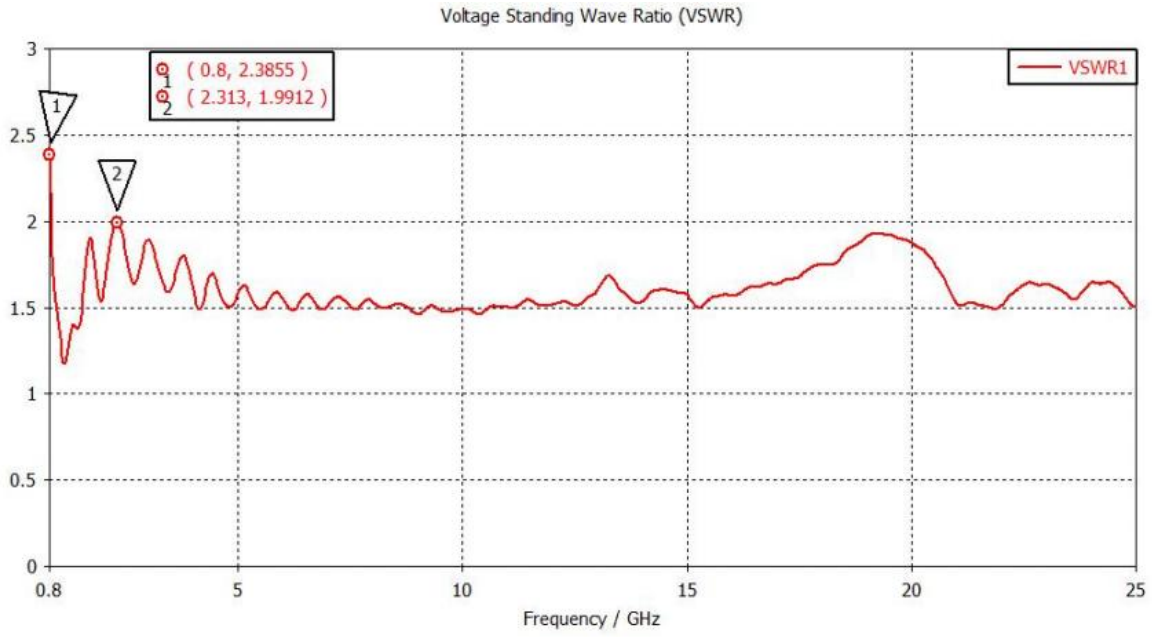

Simulation: Gain

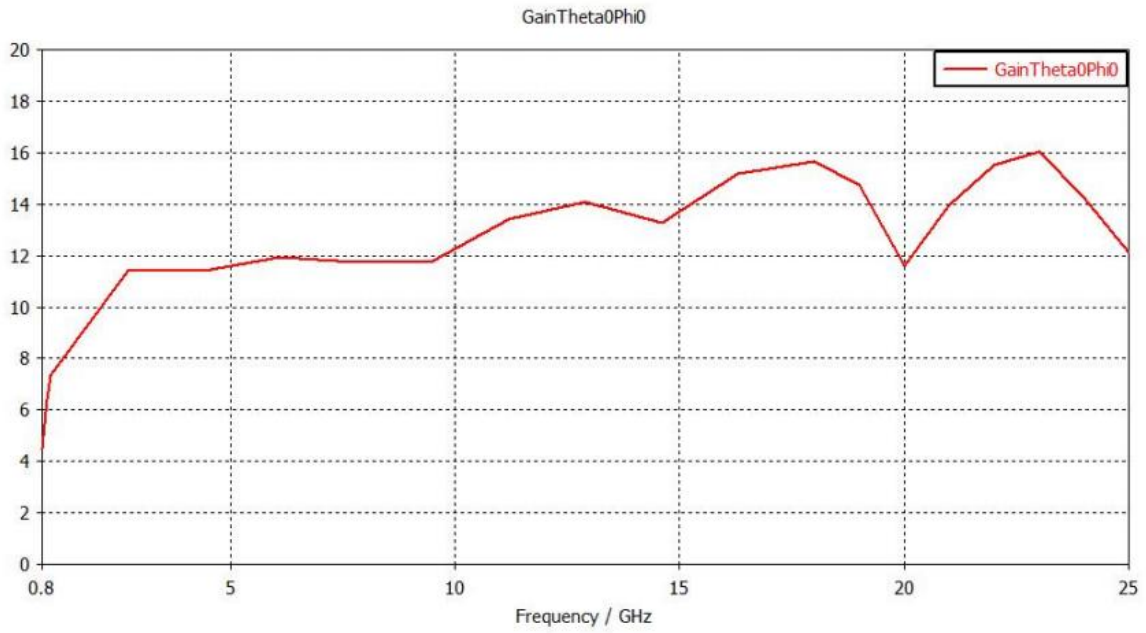

Simulation: Radiation Pattern

