



87234 Series

USB Peak/Avg Power Meter

User's Manual



Ceyear Technologies Co., Ltd.

This Manual applies to the following models of USB Peak/Avg Power Meter based on the firmware version of 1.0 and higher.

- 87234D USB Peak/Avg Power Meter
- 87234E USB Peak/Avg Power Meter
- 87234F USB Peak/Avg Power Meter
- 87234L USB Peak/Avg Power Meter

Version: C.2 July 2022, Ceyear Technologies Co., Ltd.

Service Consultation: 0532--86889847 400--1684191

Technical support: 0532--86880796

Quality Supervision: 0532--86886614

Fax: 0532--86889056

Website: www.ceyear.com

Email: techbb@ceyear.com

Address: No. 98, Xiangjiang Road, Qingdao Economic & Technological Development Zone, Shandong Province

Postal code: 266555

Foreword

Thank you for choosing and using 87234 series Peak/Avg Power Meter developed and produced by Ceyear Technologies Co., Ltd.!! With high, precision and frontier technologies comprehensive, the product enjoys high quality and cost performances compared with similar products.

We will take the responsibility to maximally meet your needs and provide you with high-quality measuring instruments and first-class after-sales service. We aim to provide "high quality and considerate service", and operate on the principle of making customers satisfactory with our products and services.

Manual No.

AV2.984.1302SS

Version

C.2 2022.07

Ceyear Technologies Co., Ltd.

Manual Authorization

The contents of this manual are subject to change without notice. The contents and terms used in this manual are interpreted by Ceyear Technologies Co., Ltd.

The copyright of the manual belongs to Ceyear

Technologies Co., Ltd, no modification or alteration can be made to the manual contents by any unit or person without approval of the Institute, and no reproduction or propagation of the manual can be made for profits, otherwise, Ceyear Technologies Co., Ltd reserves the right of pursuing legal responsibilities from any infringer.

Product warranty

The warranty period of this product is 18 months from the date of shipment. The instrument manufacturer will repair or replace the damaged components according to the user's requirements and actual conditions within the warranty period. For specific maintenance issues, see the contract.

Product quality certificate

This product is guaranteed to meet the specifications in this manual from the date of shipment. The calibration and measurement are completed by measuring bodies with national qualification, with relevant data to be provided for reference by users.

Quality/Environmental Management

This product complies with the quality and environmental management systems during R&D, manufacturing and testing. Ceyear Technologies Co., Ltd. is qualified and has passed ISO 9001 and ISO 14001 management systems.

Safety Precautions

Warning

The symbol "Warning" indicates a hazard. It reminds the user to pay attention to a certain operation process, operation method or the like. In case of any failure of observing the rule or maloperation, personal injury can occur. Further operation cannot be proceeded until the warning conditions are fully understood and met.

Notice

The "Notice" symbol indicates some important information which will not cause danger. It reminds the user to pay attention to a certain operation process, operation method or the like. Failure to observe the rules or operate correctly may cause damage to the instrument or loss of important data. Proceed to the next step only after fully understanding and meeting the caution conditions indicated.

Contents

1. Manual navigation.....	1
1.1. About the Manual	1
1.2 Related Documents	2
2 Overview.....	5
2.1 Product Overview	5
2.2 Safe Operation Guide.....	6
3 Quick Start	11
3.1 Get Prepared.....	11
3.2 User check	17
3.3 Configuration Methods.....	19
4 Operation Guide	25
4.1 Test Panel Introduction.....	25
4.2 Test Panel Operation.....	34
4.3 Average power measurement.....	37
4.4 Pulse power measurement.....	38
5. Remote control.....	41
5.1 Remote Control Basics.....	41
5.2 Instrument Program Port and Configuration	56

5.3 Basic VISA interface programming.....	56
5.4 I/O library.....	59
6 Troubleshooting and after-sales services	63
6.1 Working Principles.....	63
6.2 Troubleshooting and debugging	64
6.3 Error Messages.....	65
6.4 Method to Obtain After-sales Services	65
7 Technical indicators and testing methods	67
7.1 Statement.....	67
7.2 Product features.....	67
7.3 Technical Indicators.....	68
7.4 Option Information	70
7.5 Additional information	71
7.6 Performance characteristics test	72

1. Manual navigation

This chapter introduces the user's manual functions, chapter structure and main contents of the 87234 series Peak/Avg Power Meter, as well as the instrument-related documents provided to users.

- [About the Manual.....1](#)
- [Related Documents.....2](#)

1.1. About the Manual

This manual introduces the basic functions and basic operating methods of the 87234 series Peak/Avg Power Meter. It describes such contents as product features, basic operations, configuration guide, menu description, remote control, maintenance, technical indicators and testing methods, etc. of the instrument to help users get familiar with and master the operation method and key points of the instrument as soon as possible. To facilitate your skillful use of such instrument, please read carefully and follow this manual in advance for correct operation.

This manual contains the following chapters:

- Overview

This part introduces in general the main performance characteristics, typical application examples and safety precautions of operation for 87234 series Peak/Avg Power Meter. The purpose is to enable users to have a preliminary understanding of the main performance characteristics of the instrument and to guide users to operate the instrument safely.

- Quick Start

This chapter introduces the pre-operation inspection, instrument browsing, basic configurations, configuration window description and data storage of 87234 series Peak/Avg Power Meter. so that users can have a preliminary understanding of the instrument itself and its configuration processes as a preparation for the comprehensive introduction of the configuration operations of the instrument hereinafter. This section contains some contents consistent with the relevant sections in the Quick Start.

- Operation Guide

This guide introduces the operation methods of various configuration functions of the instrument in detail, including: configuring the instrument, starting the configuration process and obtaining the configuration results, etc. This part mainly includes two parts: basic operation guide and advanced operation guide. For users who are not familiar with 87234 series Peak/Avg Power Meter, the basic operation guide introduces and enumerates each function systematically and in detail so that users can understand and master some basic usage of the signal generators, such as setting trigger, time base, and frequency, etc. The advanced operation guide introduces relatively complicated testing processes and advanced operation skills for users who have basic knowledge about using the USB Peak/Avg Power Meter but are not familiar with some special usage, and guides them to implement the measurement processes. Examples include measurements of pulse modulated signals, CCDF statistical measurements, and the use of gates.

- Menus

This part introduce the menu structure and menu items according to the functions to facilitate the users to query for reference.

- Remote Control

The methods for remote control of the instrument are summarized to make users get familiar with remote control quickly. It is divided into four parts: program control fundamentals, introducing concepts related to program control, software configuration, program control ports, SCPI commands, etc; port configuration methods, introducing the connection methods and

1.2 Related Documents

software configuration methods for program-controlled ports of 87234 series USB Peak/Avg Power Meter; basic programming methods for VISA interfaces, giving basic programming examples in the form of text description and sample codes to enable users to quickly master the programming methods; I/O function library, introducing the basic concepts of instrument drivers and the basic installation and configuration instructions of IVI-COM/IVI-C drivers.

- Troubleshooting and Repair

This part includes the introduction of the working principles of the instrument, troubleshooting, error message description and repair methods.

- Technical Indicators and Testing Methods

This part introduces the product features, main technical indicators and recommended testing methods of 87234 series USB Peak/Avg Power Meter.

1.2 Related Documents

The product documentation for the 87234 series USB Peak/Avg Power Meter includes

- Quick Start Guide
- Online Help
- User's Manual
- Program Control Manual

Quick Start Guide

It introduces the configuration of the instrument and basic operations for starting configurations with the purpose of: making users quickly understand the characteristics of the instrument, master the basic settings and basic local and program-controlled operations. Main chapters include:

- Get Prepared
- Typical Applications
- Get Help

User's Manual

It introduces the functions and operation methods of the instrument in detail, including configuration, program control, and maintenance, etc.. The purpose is to guide users to fully understand the functional characteristics of the product and master common testing methods of the instrument. Main chapters include the following:

- Manual Navigation
- Overview
- Quick Start
- Operation Guide
- Remote Control
- Troubleshooting and Repair
- Technical Indicators and Testing Methods

Program Control Manual

It introduces such contents as program control programming foundation, SCPI foundation, SCPI commands, programming examples and I/O driver function library in detail. The purpose is to guide

users to quickly and comprehensively master the program control commands and methods of the instrument. Main chapters include the following:

- Remote Control
- Program Control Commands
- Programming Examples
- Error Description
- Appendixes

Online Help

Online help is integrated in the instrument, providing fast text navigation help to make it convenient for users in local and remote control operation. Both the hard keys on the front panel of the instrument or the user interface tool bar offer corresponding shortcut keys to activate this function. Main chapters are identical to those of the User's Manual.

2 Overview

This chapter introduces the main performance characteristics, main applications and main technical indicators of 87234 series USB Peak/Avg Power Meter. It also gives introductions on correct operation of the instrument and precautions such as electrical safety.

- [Product Overview.....5](#)
- [Safe Operation Guide.....6](#)

2.1 Product Overview

The 87234 series USB Peak/Avg Power Meter have a frequency range of 50MHz–67GHz and a power dynamic range of $-45\text{dBm} \sim +20\text{dBm}$. They are small, light, portable and hot-swappable. They can be widely used in the testing of microwave signal average power, peak power and other parameters in the fields of aviation, aerospace, radar, communication, electronic countermeasures, navigation and so on. The main features of the 87234 series USB Peak/Avg Power Meter are as follows:

- 1) **Accurate Average Power Measurement:** The 87234 series USB Peak/Avg Power Meter enable accurate average power measurements of up to 0.2dB, using a continuous sampling rate of 80MS/s for high measurement speed and repeatability, with a frequency range up to 67GHz and power measurement capability down to -45dBm to cover most test applications.
- 2) **Ultra Wide Pulse Power Dynamic Range:** The 87234 series USB Peak/Avg Power Meter have a peak power measurement range of $-35\text{dBm} \sim +20\text{dBm}$, enabling measurement and analysis of very small signals at high bandwidths. It also supports external triggering in Average Mode, enabling pulse power measurements down to -45dBm .
- 3) **Fast Rise and Fall Time:** The pulse power and time parameters can be measured in the development, production, installation and maintenance of radar systems and related components. The 87234 series has a video bandwidth of up to 30MHz and a rise/fall time of less than or equal to 13ns, allowing signals with a 50ns pulse width to be measured.
- 4) **Internal/External Zeroing:** Each 87234 series Peak/Avg power meter can be internally zeroed by switch control, so there is no need to disconnect the power meter from the device under test during use, speeding up measurement, reducing connector wear, and lowering measurement uncertainty.
- 5) **Internal/External Trigger:** The external trigger can accurately trigger small signals close to the lower noise limit. The 87234 series has built-in trigger input and trigger output, which can connect the external trigger of the device under test to the power meter via standard BNC to MMCX cable.
- 6) **Automatic Measurement:** The automatic measurement function can help users in complex measurements without tedious menu settings, and the pulse measurement results can be obtained with one click, improving user testing efficiency.
- 7) **Statistical Measurement:** The 87234 series USB Peak/Avg Power Meter can realize two CCDF statistical functions. The normal CCDF performs statistical analysis of waveforms in free-run and continuous trigger modes; the gated CCDF is used in conjunction with the gate signal and performs statistical analysis of waveforms within the gated signal only.
- 8) **Built-in Radar and Wireless Applications:** The 87234 series USB Peak/Avg Power Meter have built-in radar and wireless presets, including GSM, EDGE, CDMA, WCDMA, BLUETOOTH, WiMAX™ and LET.
- 9) **Compact and Portable:** The 87234 series USB Peak/Avg Power Meter do not require a power host and can be powered and communicated via the USB 2.0 interface, thus allowing for a portable and lightweight solution for field testing.

2.2 Safe Operation Guide

Please read carefully and strictly observe the following precautions!

We will spare no effort to ensure that all production processes meet the latest safety standards and provide users with the highest safety guarantee. The design and testing of our products and the auxiliary equipment used meet relevant safety standards, and a quality assurance system has been established to monitor the product quality and ensure the products to always comply with such standards. In order to keep the equipment in good condition and ensure operation safety, please observe the precautions mentioned in this manual. If you have any questions, please feel free to consult us.













In addition, the correct use of this product is also your responsibility. Please read carefully and observe the safety instructions before starting to use this instrument. This product is suitable for use in industrial and laboratory environments or field measurement. Always use the product correctly according to its restrictions to avoid personal injury or property damage. You will be responsible for problems caused by improper use of the product or noncompliance with the requirements, and we will not be held responsible. **Therefore, in order to prevent personal injury or property damage caused by dangerous situations, please always observe the safety instructions.** Please keep the basic safety instructions and the product documentation properly and deliver them to end users.





2.2.1 Safety Marks

2.2.1.1 Product-related Marks

Safety marks on the products are described as follows (Table 2.1):

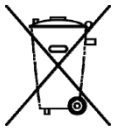
Table 2.1 Products safety marks

Symbol	Meaning	Symbol	Meaning
	Notice, reminding users of information to be paid special attention to. It reminds users of the operation information or instructions to be paid attention to.		Power ON/OFF
	Notice, handling heavy equipment.		Standby indication
	Danger! Hazard of electric shock.		DC
	Warning! Hot surface.		AC
	Protective conductive end		DC/AC
	Ground		Reinforced insulation protection of the instrument

	Ground terminal		EU mark for batteries and accumulators. Please refer to Item 1 of "2.2.7 Waste Disposal/Environmental Protection" in this section for specific instructions.
	Notice, please handle classical sensitive devices with care.		EU mark for separate collection of electronic devices. Please refer to Item 2 of "2.2.7 Waste Disposal/Environmental Protection" in this section for specific instructions.
	Warning! Radiation. Please refer to Item 7 of "2.2.4 Operation Precautions" in this section for specific instructions.		

2.2.1.2 Manual-related marks

In order to remind users to operate the instrument safely and pay attention to relevant information, the following safety warning marks are used in the product manual, which are explained as follows:



Danger mark, personal injury or equipment damage may be caused if not avoided.



Warning mark, personal injury or equipment damage may be caused if not avoided.



Caution mark, slight or medium personal injury or equipment damage may be caused if not avoided.



Notice mark, indicating some important information which will not cause danger.



Tips on information about the instrument and its operation.

2.2.2 Operation Status and Locations

Please note before operating the instrument:

1) Unless otherwise stated, the 87234 series USB Peak/Avg Power Meter have a non-operating temperature: $-40^{\circ}\text{C} \sim +70^{\circ}\text{C}$; and operating temperature: 0°C to 50°C .

2.2 Safe Operation Guide

2) Do not place the instrument on surfaces with water, vehicles, cabinets, tables and other objects that are not fixed. Please place the instrument securely and fix it on the surface of a solid object (e.g., an ESD workbench).

3) Do not place the instrument on the surface of a heat-dissipating object (e.g., a radiator). The operating environment temperature shall not exceed the value specified in the description of relevant indicators of the product. Overheating of the product will lead to electric shock, fire and other risks.

4) The instrument is required to be pre-heated for 30 min for cold start, and it will reach internal temperature balance after pre-heating for 2 h at a stable ambient temperature. After the instrument is placed at ambient temperature for 2h, preheated and passes thorough user calibration, it should meet various performance indicators.

2.2.3 Electrical Safety

Precautions for electrical safety of the instrument:

1) Unless otherwise allowed, do not open the housing of the instrument, which may expose internal circuits and devices of the instrument and cause unnecessary damage.

2) When opening the housing of the instrument, do not place objects not belonging to the interior of the instrument, otherwise, short circuit, damage to the instrument and even personal injury may be caused.

3) Unless otherwise stated, the instrument has not received any waterproof treatment, so keep the instrument from contacting with liquid to prevent damage to the instrument or even personal injury.

4) Do not place the instrument in an environment where fog is easily formed, for example, moving the instrument in a environment where cold and heat are in alternation, where water droplets formed on the instrument may cause electric shock and other hazards.

2.2.4 Operation Precautions

1) Instrument operators need to have certain professional and technical knowledge, good psychological quality, and certain emergency response capabilities.

2) Before moving or transporting the instrument, please refer to the relevant instructions in "2.2.6 Transportation" of this section.

3) The inevitable use of substances (e.g. nickel) in the production process of the instrument may cause allergy to personnel. If an operator of the instrument has allergic symptoms (e.g. rash, frequent sneezing, ophthalmia or dyspnea) during the operations, please seek medical care in time to find out the reason and solve the symptoms.

4) Please refer to the relevant instructions in "2.2.7 Waste Disposal/Environmental Protection" of this section before disassembling this instrument for disposal.

5) RF instruments will generate high electromagnetic radiation, during which period, pregnant women and operators with cardiac pacemakers need special protection. If the radiation level is high, corresponding measures may be taken to remove the radiation sources to prevent personal injury.

6) In case of fire, the damaged instrument will release toxic substances. Therefore, the operators should wear appropriate protective equipment (e.g. Protective masks and exposure suits) for safety.

7) The EMC grade should meet the requirements specified in 3.9.1 of GJB3947A-2009.

2.2.5 Maintenance

1) Only authorized and specially trained operators are allowed to open the casing of the instrument. Before such operations, it is required to disconnect the power cord to prevent damage to the instrument or even personal injury.

2) The repair, replacement and maintenance of the instrument should be performed by dedicated electronic engineers of the manufacturer, and the parts subject to replacement and maintenance should receive safety tests to ensure safe use of the product in the future.

2.2.6 Transportation

1) If the instrument is heavy, please handle it with care. If necessary, use tools (a crane, for instance) to move the instrument so as to prevent damaging the body.

2) The handle of the instrument is suitable for personal handling of the instrument and cannot be fixed on the transportation equipment when during the transportation of the instrument. In order to prevent property loss and personal injury, please follow the manufacturer's safety regulations on the transportation of the instrument.

3) When operating the instrument on the vehicle, the driver should drive carefully to ensure transportation safety, and the manufacturer is not responsible for any emergencies during the transportation. Therefore, please do not use this instrument during the transportation, and reinforcement and preventive measures should be taken to ensure the transportation safety of the product.

2.2.7 Waste disposal/environmental protection

1) Do not dispose of devices marked with batteries or accumulators together with unclassified waste; Instead, such devices should be collected separately and disposed of in a suitable collection location or through the customer service center of the manufacturer.

2) Do not dispose of waste electronic devices together with unclassified waste; Instead, such devices should be collected separately. The manufacturer has the right and responsibility to help end users dispose of waste products. If necessary, please contact the customer service center of the manufacturer for corresponding disposal so as not to damage the environment.

3) During mechanical or thermal processing of the product or its internal components, toxic substances (dust of heavy metals, such as lead, beryllium, and nickel, etc.) may be released. Therefore, specially trained technicians with relevant experience are required to disassemble the product to avoid personal injury.

4) During the reprocessing, please refer to the safety operation rules recommended by the manufacturer to dispose of toxic substances or fuel released from the product with specific methods to avoid causing personal injury.

3 Quick Start

This chapter introduces the pre-operation precautions and the common basic configuration methods of the 87234 series USB Peak/Avg Power Meter. so that users can have a preliminary understanding of the instrument itself and its configuration processes.

- [Get Prepared.....11](#)
- [User Check.....17](#)
- [Basic Configurations.....19](#)

3.1 Get Prepared



Avoid damaging the instrument

Pay attention to the follow to avoid electric shock, fire and personal injury:

- Do not open the cabinet arbitrarily;
- Do not try to disassemble or refit any part of the instrument not mentioned in the manual. Otherwise, such consequences as reduced electromagnetic shielding property and internal component damage can occur, affecting product reliability. If the product is under warranty, we will no longer provide free maintenance.
- Please carefully read the relevant contents in "2.2 Safe Operation Guide" of this manual and the safety precautions therein for operation. Also please pay attention to the requirements for specific operating environment mentioned in the data page.



Electrostatic Protection

Take electrostatic protection measures at workplaces to avoid any damage caused by the instrument. For details, please refer to the relevant contents in "2.2 Safe Operation Guide" of the manual.

3.1 Get Prepared

Notice

Pay attention to the following when operating the instrument:

Improper operation location or configuration may damage the instrument or the connected instruments. Pay attention to the following before powering on the instrument:

- Keep the instrument dry;
- Keep the instrument level, and arrange it properly;
- Make sure the environment temperature meets with the requirement noted in the data page;
- Make sure the port input signal amplitude is within the range specified;
- Make sure the signal output port is connected properly, without any overload.

Tips

Effect of electromagnetic interference (EMI)

Electromagnetic interference will affect the configuration result, therefore, please:

- Select proper shield cables. For example, to use the double-shielded RF/network connection cable;
- Please close any cable connection port that is enabled but temporarily unused or connect a matching load to the connection port in time;
- Please refer to the EMC level labels in the Data Page.

3.1.1 Environmental Requirements

The operation sites of 87234 series USB Peak/Avg Power Meter should meet the following environmental requirements:

1) Operating environment

The operating environment should meet the following requirements:

Table 3.1 Environmental requirements of 87234

Temperature	0°C~50°C
Humidity	When the temperature is lower than 10 °C, the humidity is not controlled When temperature range is 10°C-30°C, the relative humidity is (5-95)% When temperature range is 30°C- 40°C, the relative humidity is (5-75)% When the temperature is above 40 °C, the relative humidity is (5-45)%
Elevation	0 - 4,600 m
Vibration	Frequency 5 Hz ~500 Hz

Notice

The above environmental requirements are only applicable to the operating environment factors of the instrument, and are not within the scope of technical indicators.

2) Electrostatic protection

Static electricity is extremely destructive to electronic components and equipment. Usually we take two anti-static measures: conductive table mat and wrist strap; Conductive floor mat and ankle strap. Using the above two anti-static measurements at the same time can provide good antistatic protection. If using one of them, only the former can provide antistatic protection. 1M Ω earth isolation resistor must be provided for the antistatic components at least for ensuring user safety.

Correctly take the following antistatic measures to techniques to reduce electrostatic damages:

- Ensure all instruments are grounded properly, so as to avoid any static electricity.
- Let the internal/external conductor of the cable contact the ground shortly before connecting the coaxial cable with the instrument.
- Operators must wear anti-static wrist straps or take other antistatic measures before touching the joints, core or conducting any assembly.

Warning

Voltage range

The above-mentioned anti-static measures cannot be applied when the voltage exceeds 500V.

3.1.2 Correct Use of connectors

Connectors are often used in various tests of USB Peak/Avg Power Meter. Although the connectors of calibration pieces, test cables and analyzer measuring ports are designed and manufactured according to the highest standards, the service life of all these connectors is still limited. Due to the inevitable wear and tear during normal use, the performance indicators of the connectors will decrease or even be unable to meet the measurement requirements. Therefore, correct maintenance and measurement connection of the connectors can not only ensure accurate and repeatable measurement results, but also prolong the service life of the connectors and reduce the measurement costs. In actual use, the following aspects should be paid attention to:

1) Connector check

When conducting connector inspection, anti-static wrist band should be worn. It is recommended to use a magnifier to check the following items:

- a) Whether the electroplated surface is worn or not and whether there are deep scratches;
- b) Whether the thread is deformed;
- c) Whether there are metal particles on the threads and the joint plane of the connector;
- d) Whether the inner conductor is bent or broken;
- e) Whether the screw sleeve of the connector rotates improperly.

⚠ Caution

Check the connector to prevent damaging ports of the instrument

Any damaged connector may damage the good connector connected to it even when measuring the connection for the first time. In order to protect each interface of the signal generator itself, the connector must be checked before connector operation.

2) Connection method

Before the connection, the connectors should be inspected and cleaned to ensure cleanness and intactness. Anti-static wrist straps should be worn before connection. The correct connection method and steps are as follows:

Step 1. As shown in Figure 3.1, align the axes of the two interconnecting devices to ensure that the pin of the male connector slides concentrically into the socket of the female connector.



Figure 3.1 Axes of interconnected devices are in a straight line

Step 2: as shown in Fig.3.2, move the two connectors leveled together so that they can be smoothly engaged. Rotate the screw sleeve of the connector (note, not the rotating connector itself) until it is tightened, and there can be no relative rotational movement between the connectors during the connection.

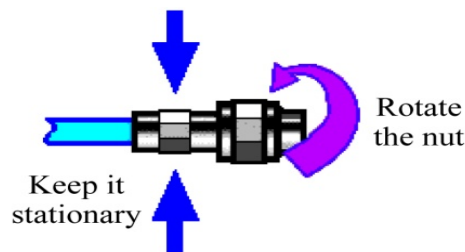

Fig.3.2 Connection method

Step 3. As shown in Figure 3.3, tighten the connectors with a torque wrench to complete the connection. Pay attention that the torque wrench should not exceed the initial folding point. Use an auxiliary wrench to prevent the connector from rotating.

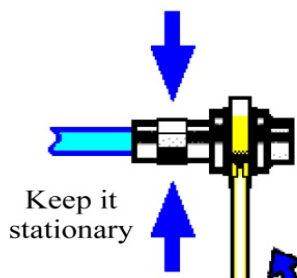

Fig.3.3 Finish the connection with a torque wrench

3) Disconnection method

Step 1. Support the connectors to prevent any connector from being twisted, shaken or bent;

Step 2. An open-ended wrench can be used to prevent the connector body from rotating;

Step 3. Loosen the screw sleeve of the connector with another wrench;

Step 4. Rotate the screw sleeve of the connector by hand to complete the disconnection;

Step 5. Pull the two connectors levelly apart.

4) Usage of a torque wrench

The use of a torque wrench is shown in Fig.3.4. The following points should be paid attention to when using it:

- Confirm that the torque of the torque wrench is correct set before use;
- Ensure that the angle between the torque wrench and another wrench (used to support a connector or a cable) is within 90° before applying force;
- Grasp the end of the torque wrench handle gently, and apply force in the direction perpendicular to the handle until reaching the folding point of the wrench.

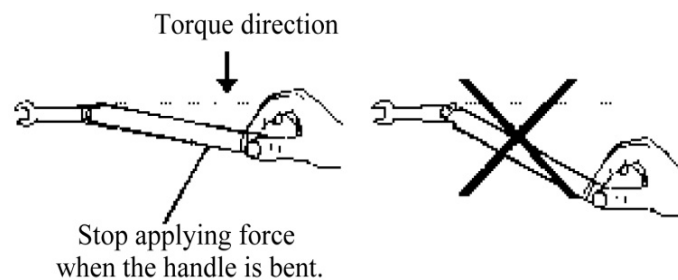

Fig.3.4. Usage of a torque wrench

5) Use and storage of connectors

- a) The connectors should be covered by protective sleeves when not in use;
- b) Do not mix various connectors, air lines and standard calibration pieces in a box because this is one of the most common causes of connector damage;
- c) Keep the connectors and the analyzer at the same temperature. Holding a connector by hand or cleaning a connector with compressed air will significantly change its temperature. The connectors should be calibrated after its temperature is stable;
- d) Do not touch the joint plane of the connectors because the grease and dust particles on the skin are difficult to be removed from the joint plane;
- e) Do not put the contact surface of a connector downward on a hard table surface. Contact with any hard surface may damage the electroplated layer and the joint surface of the connector;
- f) Always wear anti-static wrist straps and work on a grounded conductive workbench pad, which can protect the analyzer and the connectors from electrostatic discharge.

6) Connector cleaning

When cleaning the connectors, always wear antistatic wrist straps and observe the following steps:

- a) Remove loose particles on the thread and joint plane of the connectors with clean low-pressure air, and thoroughly inspect the connectors. If further cleaning treatment is required, proceed as follows:

3.1 Get Prepared

- b) Soak (but not thoroughly soak) a lint-free cotton swab with isopropyl alcohol;
- c) Remove the dirt and debris from the joint plane and threads of the connectors with cotton swabs. When cleaning the inner surface of a connector, be careful not to apply external force to the central inner conductor and not to leave the fibers of cotton swabs on the central conductor of the connector.
- d) Let the alcohol volatilize, then blow the surface clean with compressed air;
- e) Check the connector to make sure that it is free of particles and residues;
- f) If any defects of the connector is still obvious after cleaning, it indicates that the connector may have been damaged and should not be used again. Make clear the cause of the connector damage before connection.

7) Use of adapters

When the measurement port of the power meter and the connector type used are different, adapters must be used for the connection before measurement. In addition, even if the measurement port of the power meter and the connector type of port of the DUT are the same, it is also advisable to use adapters. Both cases can protect the measurement port, prolong its service life and reduce the maintenance cost. Before connecting an adapter to the measurement port of a power meter, it is required to carefully check and clean the adapter. And a high-quality adapter should be used to reduce the influence of mismatching on measurement accuracy.

8) Joint plane of connectors

An important concept in microwave measurement is reference plane. And an analyzer, it is the benchmark reference plane for all measurements. During the calibration, the reference plane is defined as the plane where the measurement port and the calibration standard are engaged. Good connection and calibration depend on thorough and level contact between the connectors on the joint plane.

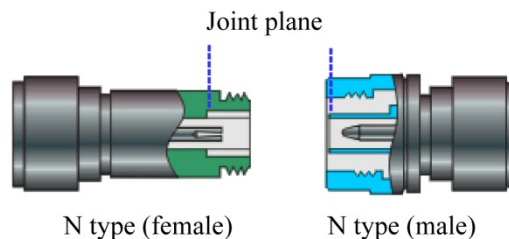

Fig.3.5 Calibration plane

3.1.3 Routine Maintenance

This section describes the routine maintenance of the 87234 series USB Peak/Avg Power Meter.

1) Cleaning instrument surface

Please follow the steps below when cleaning the surface of the instrument:

Step 1. Shut down the instrument and disconnect the power cord connected to it.

Step 2. Wipe the surface gently with dry or slightly wet soft cloth, and do not wipe the inside of the instrument.

Step 3. Do not use chemical cleaners, such as alcohol, acetone or dilutable cleaners.

2) Test Port Maintenance

Damage to the connector of 87234 series USB Peak/Avg Power Meter or the presence of dust inside the connector will affect the test results. Please maintain such kind of connectors as follows:

- The connectors should be kept away from dust and kept clean;
- To prevent electrostatic discharge (ESD), do not directly contact the joint surface;
- Do not use damaged connectors;
- Please use an air blower to clean the connectors instead of using tools such as sandpaper to grind the surface of the connector.

3.2 User check

3.2.1 Unpacking

3.2.1.1 Visual Examination

Step 1: check whether the outer package and the shockproof packing of the instrument are damaged. If there is any damage, keep the outer package for standby and proceed with the following examination steps.

Step 2: unpack, and check the mainframe and articles provided in the package for any damage;

Step 3: check carefully the articles mentioned above as per Table 3.2 for any problem;

Step 4: in case of any outer package damage, or damage or problem to the instrument or articles provided in the package, never power the instrument on or start it up! Please contact our service consultation center with the service hotline provided on the cover, and we will repair or change it as soon as possible accordingly.

3.2.1.2. Model Confirmation

Table 3.2 List of articles provided together with 87234

Name	Quantity	Function
Mainframe:		
➤ 87234	1	Mainframe
Standard Configuration:		
➤ Power cable	1	USB power supply and communication
➤ Trigger cable	2	Trigger input/output
➤ CD	1	Program
➤ Packing list	1	—
➤ Product Certificate of Conformity	1	—

3.2.2 Power-on test

1) Turning on/off the power

The 87234 series USB Peak/Avg Power Meter are powered by the USB2.0 interface of the host computer, with a supply voltage of +5V and a supply current of 500mA. Connect the USB Peak/Avg power meter to the USB port of the host computer via the USB cable when in use; and unplug the USB cable after use to power off the instrument.

2) Indicator

Table 3.3 87234 indicator working state

Color	Status
Green	Normal working state
Flashing, green	Initial power-up and zeroing operation
Red	Working stop state
Red flashing	Hardware error
Red and green flashing	Firmware upgrade

When the red flashing, please re-plug the USB Peak/Avg power meter, if it is still red flashing state, please contact our service consulting center according to the service hotline provided on the cover, and we will repair or change it as soon as possible accordingly.

3.2.3 Appearance Description

This section describes the external components of the 87234 series USB Peak/Avg Power Meter and their functions. The appearance diagram is as follows (Figure 3.6), and the detailed description is shown in Table 3.4.



Figure 3.6 Instrument appearance

Table 3.4 Appearance description

Name	Description
Power input interface	Used to receive power signal input
USB interface	For power supply and communication of USB Peak/Avg Power Meter
Trigger input interface	For external trigger signal input
Trigger interface output	For pulse modulated signal synchronous output
Indicator	Used to indicate the working state of the instrument

3.3 Configuration Methods

This section describes the hardware requirements and configuration methods for the 87234 series USB Peak/Avg Power Meter.

3.3.1 Hardware Requirements

Table 3.5 Basic configuration requirements of host computer

Host computer	
Operating system	Windows 10 32-bit and 64-bit Windows 7 32-bit and 64-bit Windows XP Linux (support for visa library)
Hardware	Processor: 1GHz or more (2GHz or more recommended) Memory: 2GB or more (4GB or more recommended) Hard disk space: 1.0GB or more Display: 1280 x 1024 or better

3.3.2 Software Installation

3.3.2.1 Hardware Driver Installation

After the USB Peak/Avg power meter is properly connected to the host computer, the system may automatically install the driver without prompting due to the difference in the original software configuration of the operating system, or the user may be prompted to install the instrument driver, or it may even be identified as other devices due to the original software configuration, as explained separately below.

(i) Automatic installation without prompts

To determine whether the hardware driver is automatically installed, right-click My Computer → Management → Device Manager. → If there is a USB Test and Measurement Deice (IVI) in the device list, right-click the entry, select "Properties", then select the "Details" tab, and select "Hardware ID" in the properties drop-down menu to view the hardware ID property of the instrument as "USB\VID_3399&PID_3800", which is the intrinsic ID of the instrument.

At this point, it indicates that the hardware driver is automatically installed. This part of the operation can be omitted and go directly to the third part.

3.3 Configuration Methods

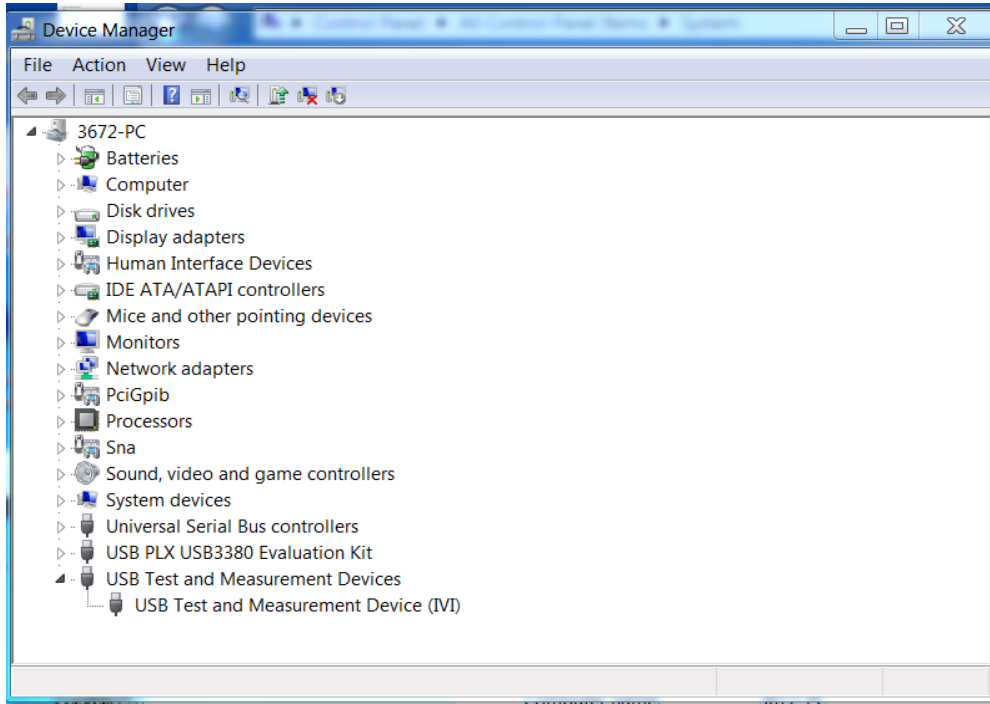

Figure 3.10 Hardware driver installation

(ii) Prompt the user to install the instrument driver

After inserting the USB Peak/Avg power meter, the system prompts to install the driver. as follows:

Step 1: After connecting the USB Peak/Avg power meter to the host computer properly, the hardware update wizard will pop up automatically

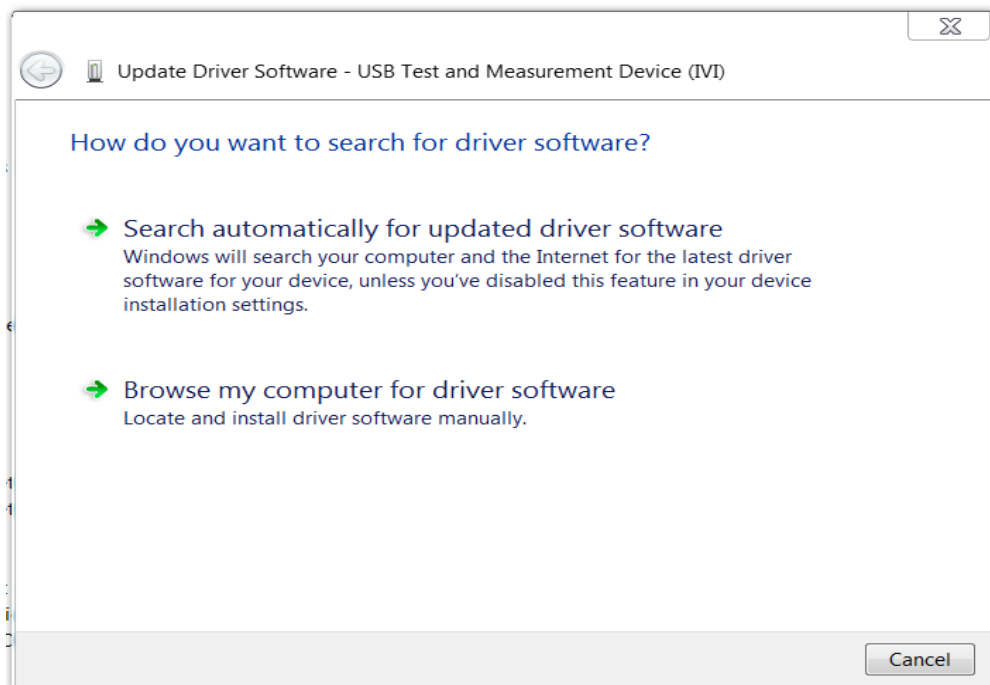

Figure 3.11 Hardware driver installations

Step 2: Select Install from list or specified location and click Next.

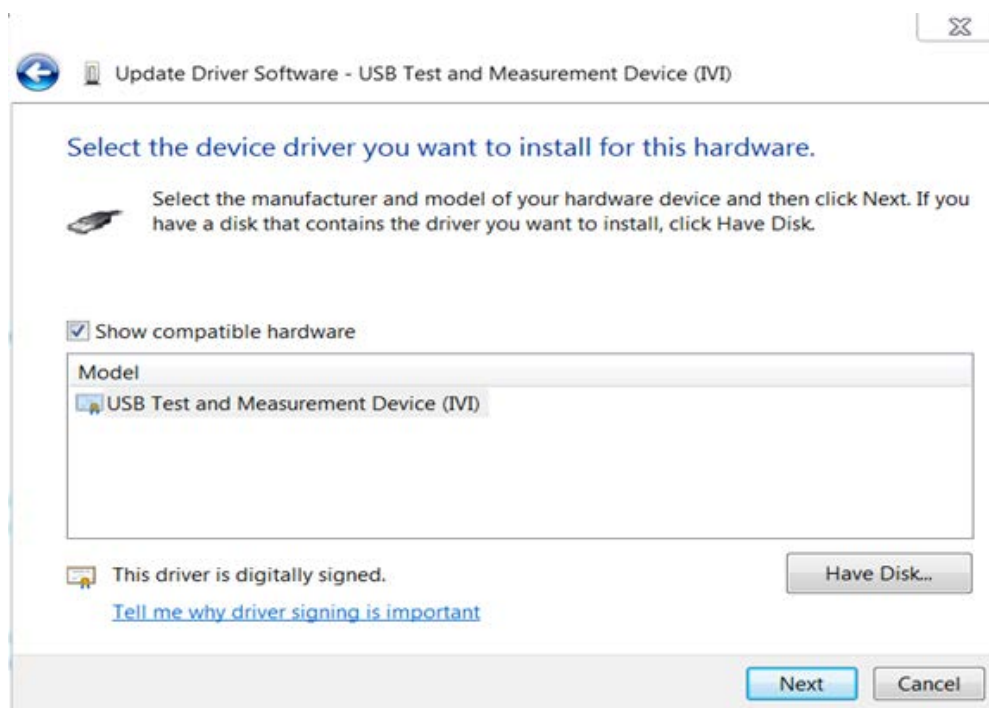

Figure 3.12 Hardware driver installations

Step 3: Select "Do not search, I will choose the driver to install", and click Next.

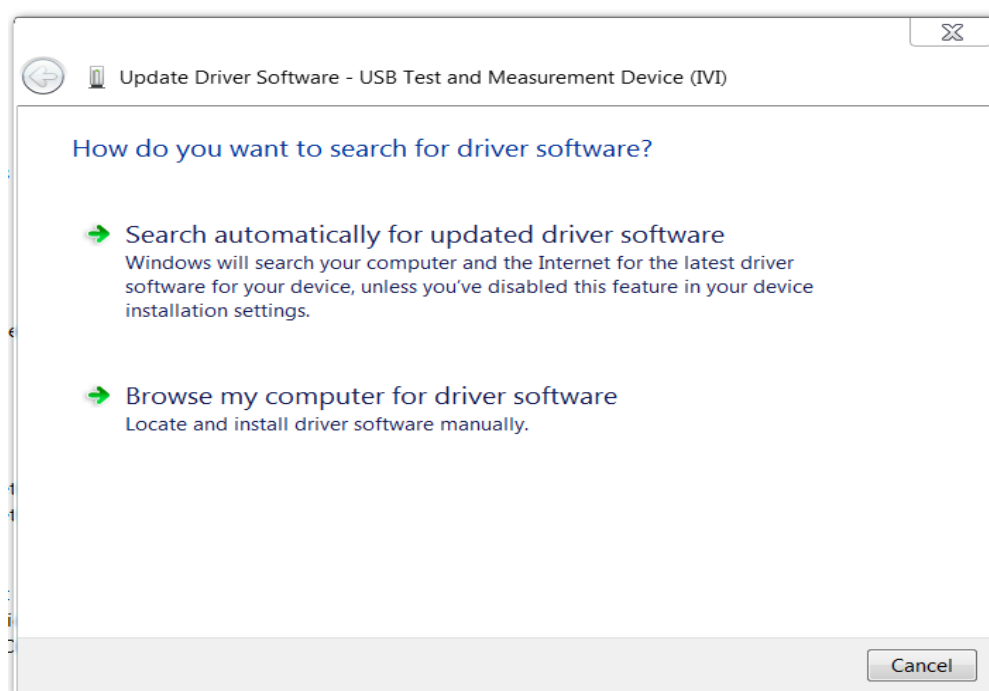

Figure 3.13 Hardware driver installations

Step 4: Select "USB Test and Measurement Device" and click Next to complete the installation.

3.3 Configuration Methods

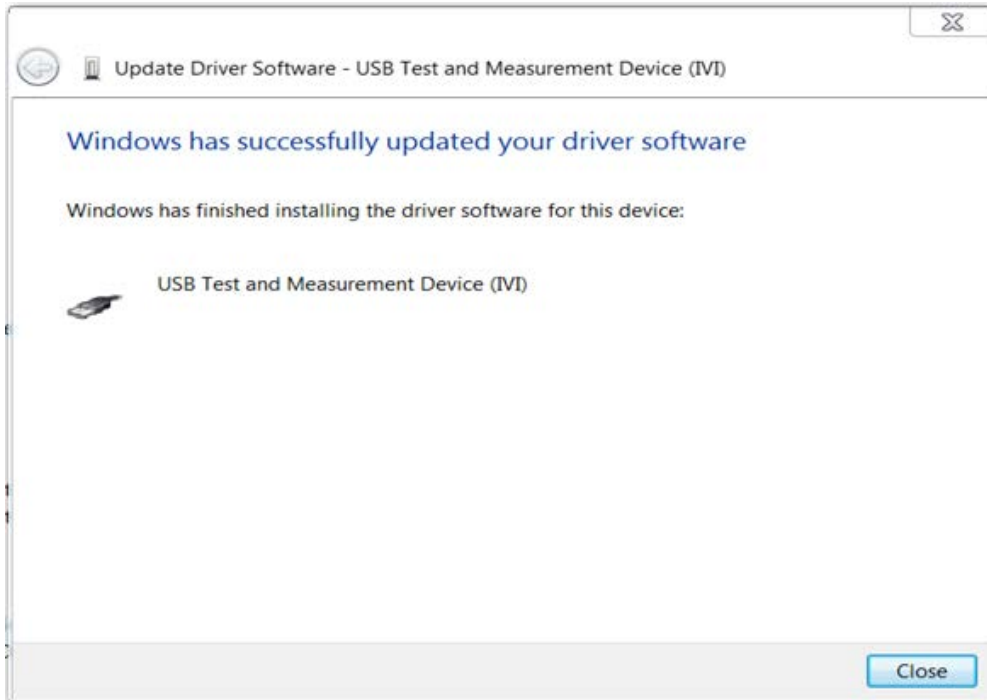

Figure 3.14 Hardware driver installations

Step 5: Click Finish and restart the computer if necessary.

(iii) The system automatically identifies it as another device and installs the default driver

Due to the different software configurations installed on the original system, the system may automatically identify the USB Peak/Avg power meter as another device, which is usually located in the "Universal Serial Bus Manager" under Device Manager.

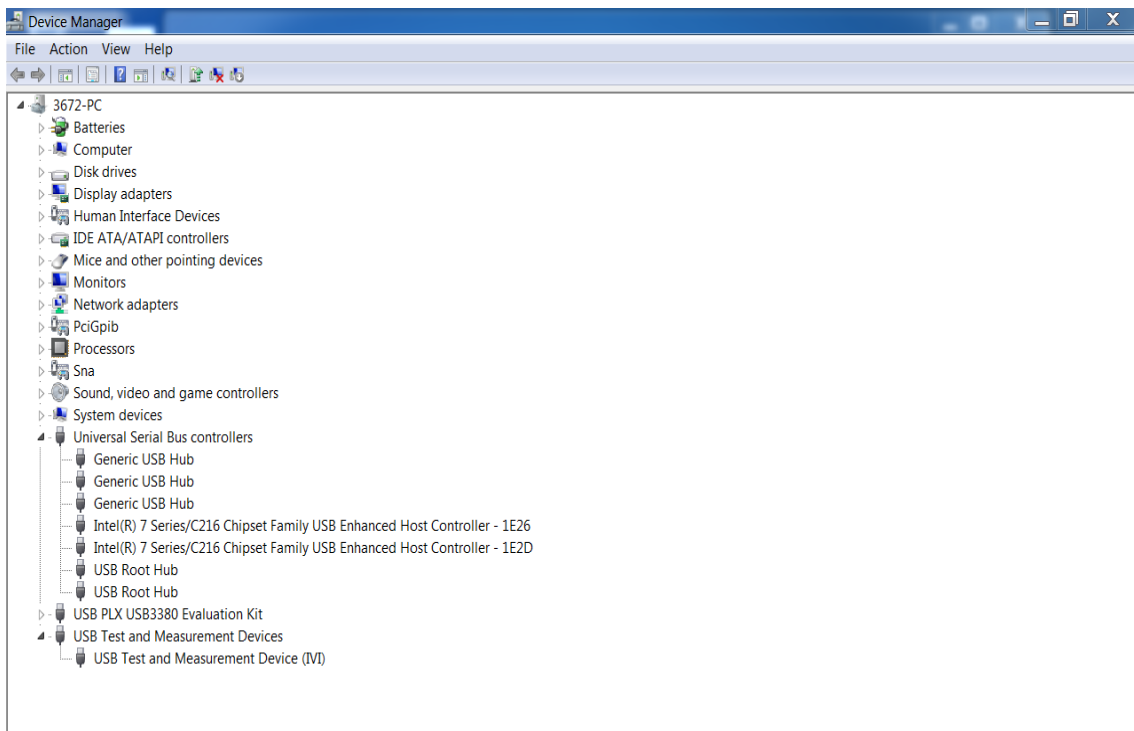

Figure 3.15 Hardware driver installations

3.3 Configuration Methods

Repeatedly plug and unplug the USB Peak/Avg power meter to check the added or reduced devices in Device Manager, and right-click Properties to check whether the "Hardware ID" in the "Details" is "USB\VID_3399&PID_3800". If the device is identified as such, right-click and select "Update Driver...". The specific steps are as follows:

Step 1: Select "Browse Computer for Driver Software".

Step 2: Select "USB Test and Measurement Device" and click Next to complete the installation.

Step 3: After successful installation, the Device Manager will show "USB Test and Measurement Device".

3.3.2.2 Run the Test Panel

Open the "Test Panel" folder in the software CD and run "87234MainWindow.exe".

Click the soft panel toolbar "Connect Device" button (please ensure that the USB Peak/Avg power meter cable is connected to the USB port of the computer host at this time), so that a dialog box will pop up as shown below, and select the device and click the Connect button, then power measurement can be carried out as needed.

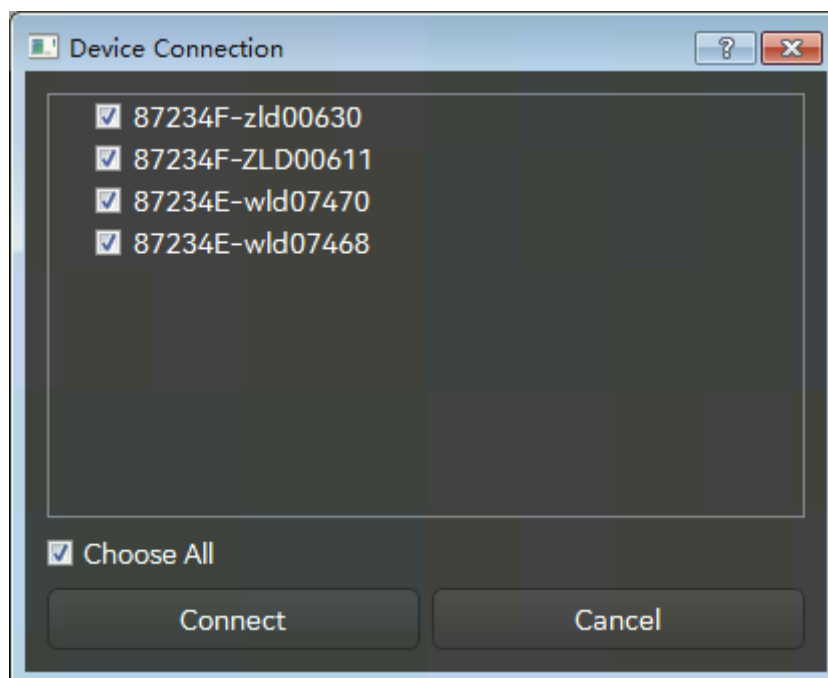

Figure 3.19 Equipment connector window

3 Quick Start

3.3 Configuration Methods



Figure 3.20 Main interface of soft panel

4 Operation Guide

This chapter introduces the operation methods of different measurement functions and details the measurement steps of the 87234 series USB Peak/Avg Power Meter.

- [Test Panel Introduction.....25](#)
- [Test Panel Operation.....34](#)
- [Average Power Measurement.....37](#)
- [Pulse Power Measurement.....38](#)

4.1 Test Panel Introduction

This section introduces the main features and basic measurement and setting methods for the user interface of the 87234 series USB Peak/Avg Power Meter, which will be used in different subsequent measurement tasks.

4.1.1 Main interface

The 87234 series USB Peak/Avg Power Meter feature a new intuitive graphical user interface that clearly displays signal power values and pulse modulation envelope waveforms. The entire operation interface is divided into different zones according to functional modules, and multiple functional modules can be operated simultaneously. This section mainly introduces the partitions and functions of the user operation interface of the USB Peak/Avg Power Meter. The operation interface is shown in Figure 4.1, and the detailed description is shown in Table 4.1.

Table 4.1 Operation interface description

No.	Name	Description
1	Menu bar	Function setting menu
2	Tool bar	Shortcuts to common tools
3	Parameter display area	Display pulse measurement parameters
4	Device display area	Display all connected devices
5	Trace display area	Display pulse traces
6	Statistical display area	Display CCDF statistics traces
7	Power display area	Display average power
7	Function setting area	Set the function menu

4 Operation Guide

4.1 Test Panel Introduction

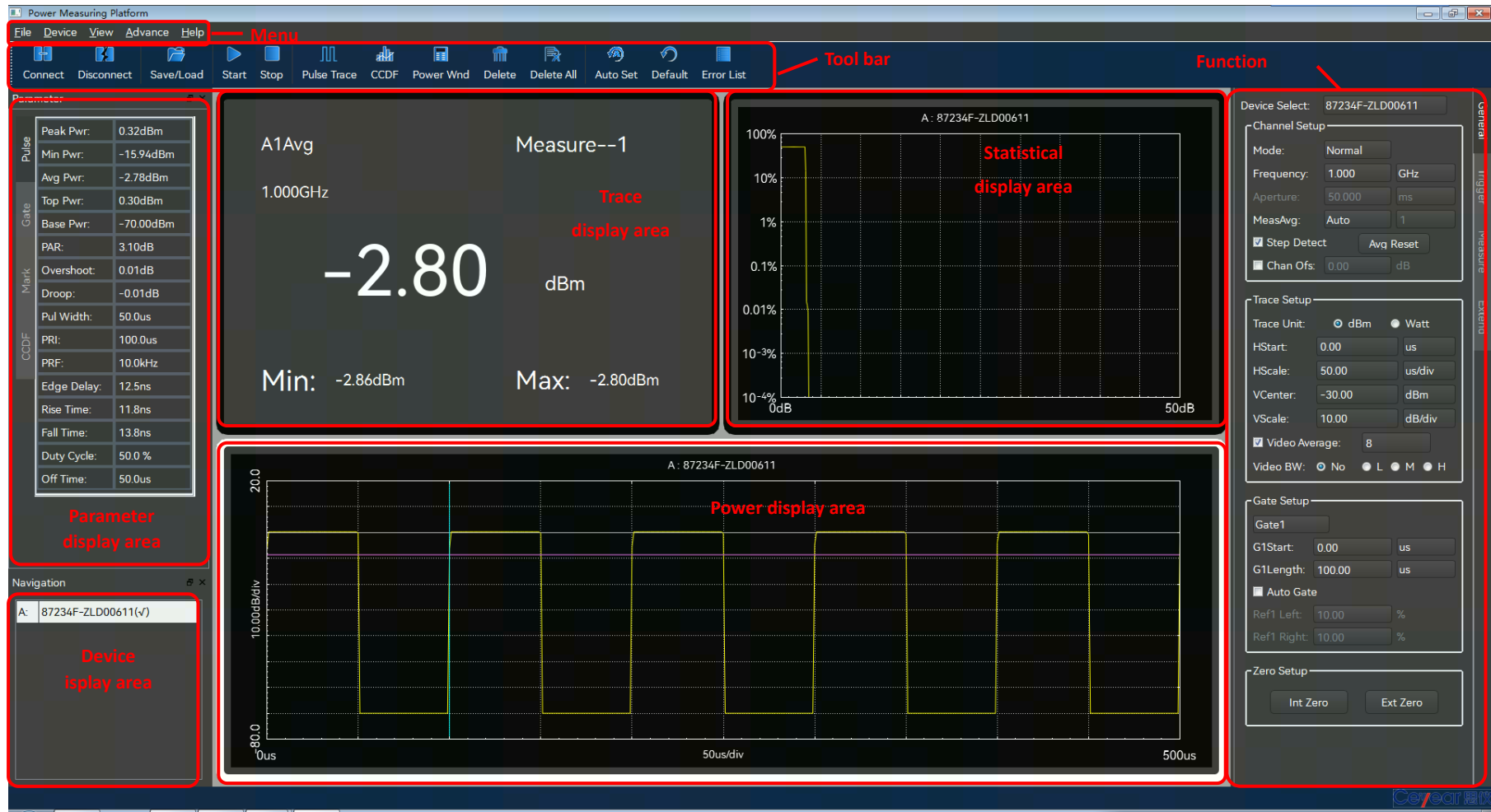















Figure 4.1 Operation main interface

4.1.2 Toolbar

Table 4.2 Toolbar

Icon	Function	Icon	Function
	Connect the device		Disconnect the device
	Open file		Save file
	Start collecting measurement results		Stop collecting measurement results
	Create trace display view		Create CCDF display view
	Create power value display view		Delete current display view
	Delete all display views		Auto Set
	Error List		

4.1.3 Menu

1) General Setup Menu

4.1 Test Panel Introduction



Figure 4.2 Channel setting

Table 4.3 Channel setting menu

Channel setting	
Device selection	When multiple devices are connected, select the current setup device.
Mode	Set the channel measurement mode to Normal or Average Only.
Frequency	Set measurement frequency.
Aperture	Set the size of aperture.
Measurement average	Turn off, automatically or manually set the average number of times with a setting range of 1-1024. Increasing the average number of measurements reduces measurement noise, but increases measurement time. Averaging reset clears the measurement results in the buffer and re-caches and calculates them, effectively reducing the measurement time when the number of averages is high.
Step detection	The initialization filter increases the measurement speed when there is a large change in the measured power.
Channel offset	Set the channel deviation applied to the measured power before the mathematical operation.

Table 4.4 Automatic average times

Power dynamic range	Resolution			
	1	2	3	4
20dBm - 0dBm	1	1	2	16
0dBm ~ -10dBm	1	4	16	32
-10dBm ~ -20dBm	1	16	64	512
-20dBm ~ -30dBm	4	64	256	512
-30dBm ~ -45dBm	64	512	512	512

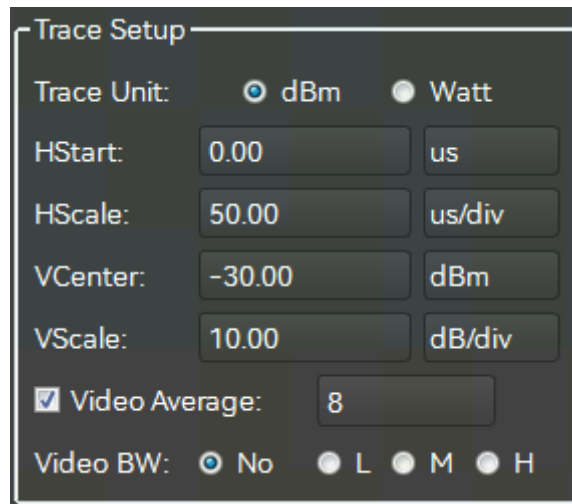

Figure 4.3 Trace setting

Table 4.5 Trace setting menu

Trace Settings	
Trace unit	Set the trace units to logarithmic and linear, respectively.
Horizontal start	Set the start time on the leftmost part of the trace window.
Horizontal scale	Set the time represented by each division in the horizontal direction of the trace window.
Vertical center	Set the power value represented by the center in the vertical direction of the trace window.
Vertical scale	Set the power represented by each division in the vertical direction of the trace window.
Trace average	The average number of times the signal has been triggered, to smooth the display trace and reduce noise.
VBW	Digital filtering is used to achieve different video bandwidths.

4.1 Test Panel Introduction

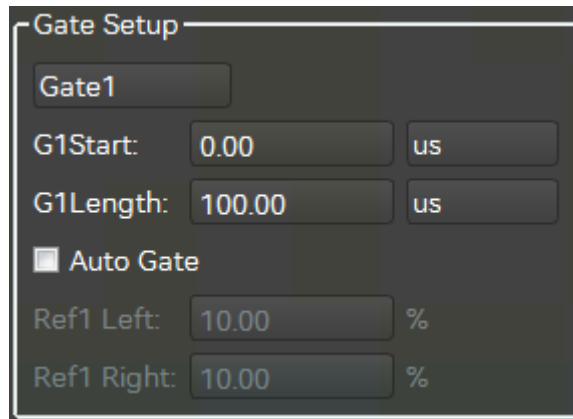

Figure 4.4 Gate setting

Table 4.6 Gate setting menu

Gate setting	
Gate setting	Select the current gate and set the start time and length of the current gate.
Auto gate setting	Open or close the automatic gate and set the left and right reference of the automatic gate.

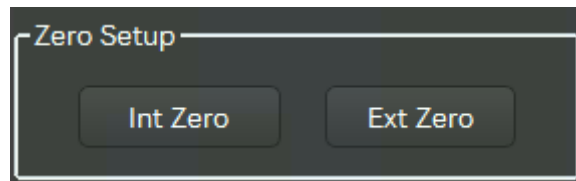

Figure 4.5 Zeroing setting

Table 4.7 Zeroing Setup Menu

Zero	
Internal zeroing	Using an internal switch, zeroing operation can be performed without turning off the signal source output.
External zeroing	External zeroing is required for measurements in Average Only mode, especially for small signal measurements, where the source output must be turned off.

2) Trigger setting menu

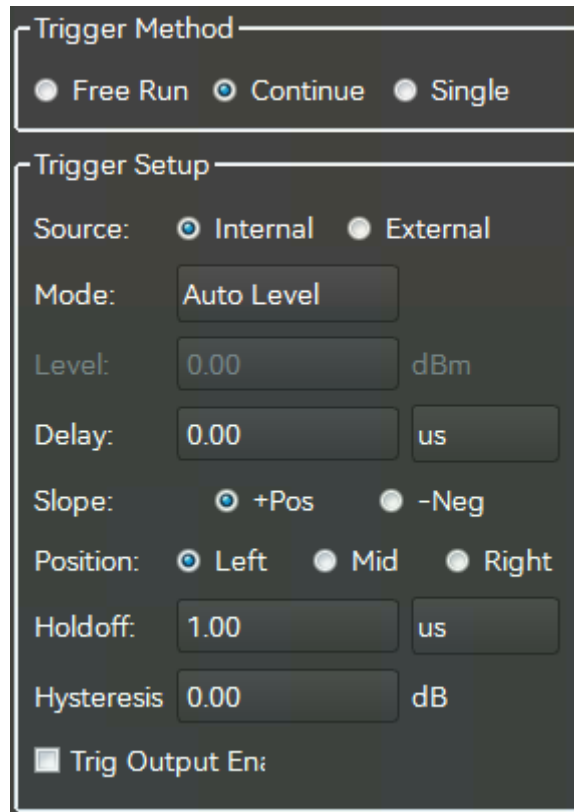

Figure 4.6 Trigger setting

Table 4.8 Trigger menu

Trigger setting	
Trigger mode	Set free-run, continuous trigger or single trigger mode.
Trigger source	Set internal trigger or external trigger.
Trigger mode	Set to Auto Level, Normal or Auto.
Trigger level	Set the trigger level manually in normal and auto trigger mode.
Trigger delay	Set the delay time between the trigger event and the gating start event, applied to all gating signals.
Trigger edge	Set to trigger on the rising or falling edge of the signal.
Trigger position	Set the current trigger edge at the left, center and right of the display area.
Trigger Holdoff	Set the trigger holdoff time, and disable the trigger within this time.
Trigger output	Enable a TTL level synchronized with the input signal.

3) Measurement setting menu

4.1 Test Panel Introduction

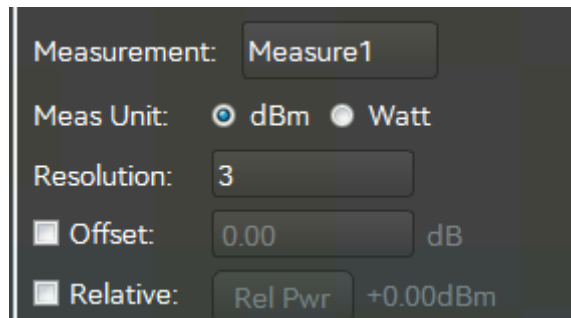

Figure 4.7 Measurement setting

Figure 4.9 Measurement setting menu

Measurement setting	
Measurement selection	Select the current measurement, 4 in total.
Units of measurement	Set to logarithmic or linear measurement units.
Resolution	Set the measurement result display resolution.
Relative	Enable relative mode, click relative power to set the reference value, and calculate the relative measurement result of the current measurement value and the reference value.
Operation	Set Input 1 and Input 2 to perform difference or ratio calculations, or disable all operations.
Input	Set the channel, gate, and measurement type for Input 1 and Input 2.

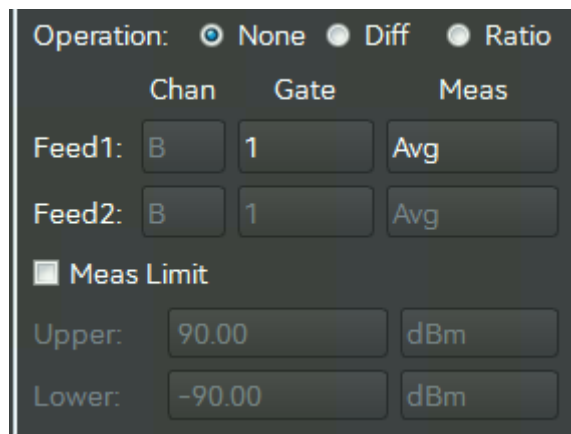

Figure 4.8 Calculation setting

Table 4.10 Calculation setting menu

Measurement setting	
Operation	Set Input 1 and Input 2 to perform difference or ratio calculations, or disable all operations.
Input	Set the channel, gate, and measurement type for Input 1 and Input 2.

4) Extended setting menu

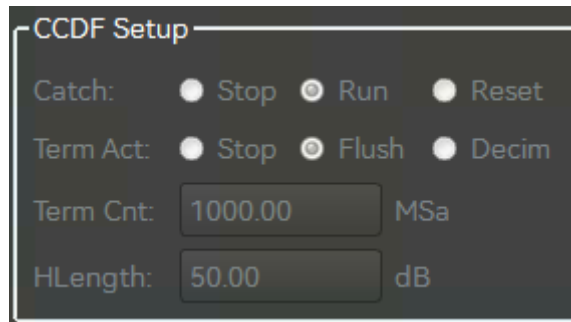

Figure 4.9 CCDF setting

Table 4.11 CCDF setting menu

CCDF settings	
Capture settings	Set to run or stop the current capture.
End operation	Set the current post capture state.
End count	Set the current capture end count condition.
End timing	Set the current capture end timing condition.
Horizontal setting	Set the horizontal scale of statistical trace display.

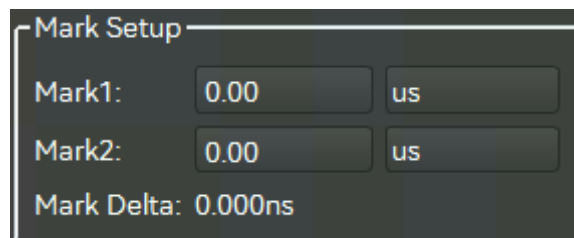

Figure 4.10 Marker setting

Table 4.12 Marker setting menu

Marker setting	
Marker	Set the horizontal position and marker difference between Marker 1 and Marker 2, and display the average power, maximum power and minimum power between markers in the parameter area.

4.2 Test Panel Operation

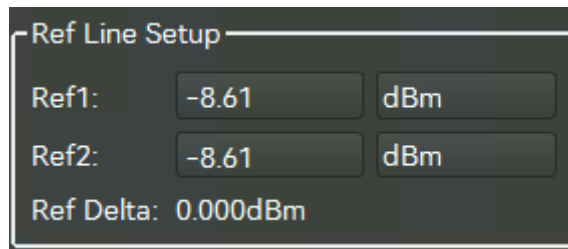

Figure 4.11 Reference line setting

Table 4.13 Reference line setting menu

Reference line setting	
Reference line	Set the vertical position and reference difference of reference line 1 and reference line 2.

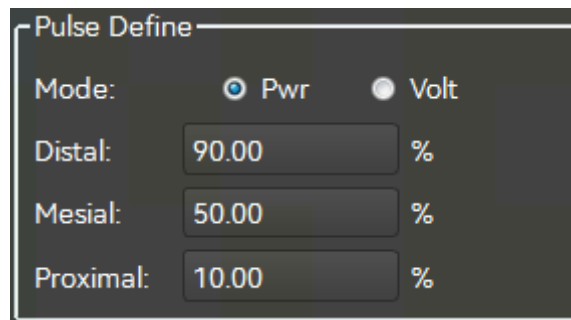

Figure 4.12 Pulse definition setting

Table 4.14 Pulse definition setting menu

Pulse definition	
Pulse definition	There are two definition modes for setting the far point, middle point and near point of the pulse.

4.2 Test Panel Operation

Step 1: Open the "Test Panel" folder in the software CD and run "87234MainWindow.exe". Click the



toolbar **Connect** to select the test instrument in the pop-up window as shown in the figure below, and then click Connect, as shown in the figure below;

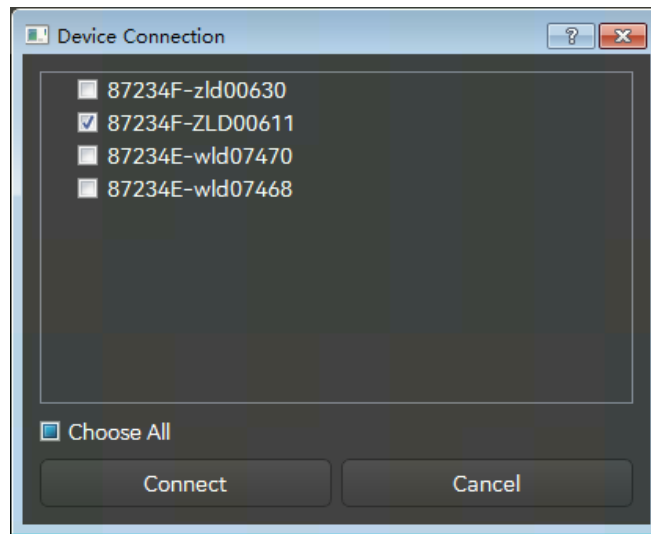
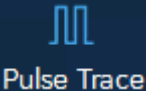

Figure 4.13 Device connection window

Step 2: Open the average power value display window in the test panel by default. The default measurement mode is set to Average Only, and the trigger mode is set to Free Run, as shown in the figure below;



Figure 4.14 Average power display window

Step 3: Click the toolbar  to open the trace display window in the test panel. The measurement mode is set to Normal and the trigger mode is set to Continuous Trigger, as shown in the figure below;

4.2 Test Panel Operation



Figure 4.15 Track display window



Step 4: Click the toolbar  to open the CCDF statistics display window in the test panel, and set the trigger mode to Free Run. The test panel displays the statistical trace, as shown in the figure below.



Figure 4.16 Statistics display window

4.3 Average power measurement

The 87234 series USB Peak/Avg Power Meter enable average power measurements.

The operation process is as follows:

Step 1: Set the signal generator amplitude to 0dBm, frequency to 1GHz and modulation mode to OFF;

Step 2: Turn on the signal generator output and run the 87234 test panel with the measurement mode defaulted to Average Only mode and set the frequency to 1 GHz;

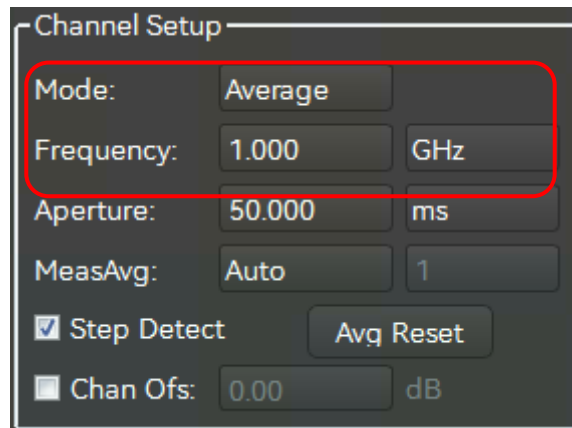

Figure 4.17 Measurement mode

Step 3: Conduct internal zeroing operation (when the measured signal is small, the source output needs to be turned off for external zeroing);

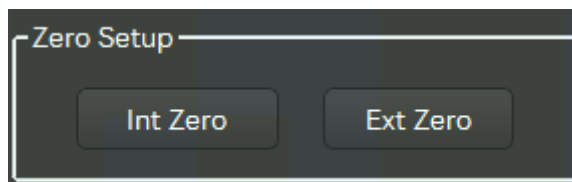

Figure 4.18 Zeroing setting

Step 4: At this time, the measured signal power value can be observed in the average power display window.



Figure 4.19 Power display window

Notice

When measuring low-level signals, it is necessary to conduct external zeroing first. When conducting external zeroing, it is necessary to turn off the output of the signal source, and then conduct the measurement, so as to ensure the accuracy of the measurement.

When the power is lower than -20dBm, it is necessary to set [Step Detn] to "Off" state, and set [Ch Avg] to "Manual", with an average of more than 100 times.

4.4 Pulse power measurement

The 87234 series USB Peak/Avg Power Meter enable pulse power measurements.

The operation process is as follows:

Step 1: Set the signal generator amplitude to 10dBm, frequency to 1GHz, turn on pulse modulation mode, and set the pulse period to 100us, and pulse width to 50us;

Step 2: Turn on the signal generator output and run the 87234 test panel with the measurement mode defaulted to Average Only mode and set the frequency to 1 GHz;

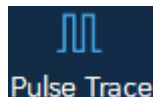

Step 3: Click the toolbar **Pulse Trace** to open the trace display window in the test panel. The measurement mode is set to Normal and the trigger mode is set to Continuous Trigger, as shown in the figure below;

Step 4: Conduct internal zeroing operation (when the measured signal is small, the source output needs to be turned off for external zeroing);

Step 5: Set the display position of the pulse waveform in the trace window via the trace menu;

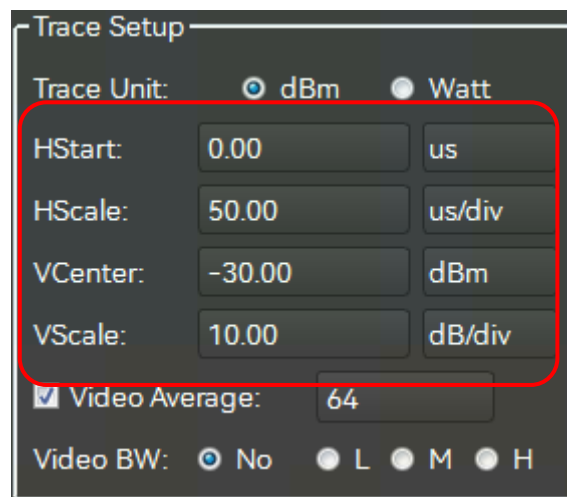

Figure 4.20 Trace setting

4.4 Pulse power measurement

Step 6: Set the starting position and length of Gate 1. The average power, peak power and peak to average ratio in the gate can be observed and measured in the parameter display area, and the automatic gate can also be used to measure the gate parameters;

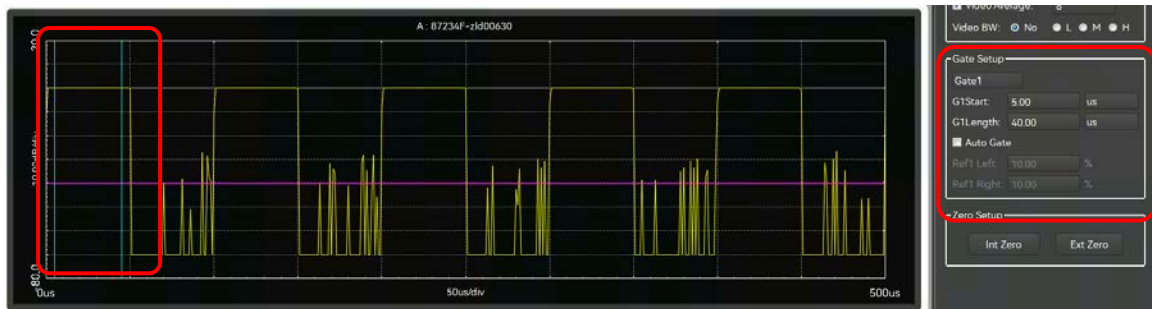

Figure 4.21 Gate measurement

Step 7: At this time, the pulse amplitude and time parameters can be observed in the pulse parameters of the parameter display area.

Peak Pwr:	-0.00dBm
Min Pwr:	-25.13dBm
Avg Pwr:	-3.01dBm
Top Pwr:	-0.01dBm
Base Pwr:	-69.98dBm
PAR:	3.01dB
Overshoot:	0.01dB
Droop:	-0.01dB
Pul Width:	50.0us
PRI:	100.0us
PRF:	10.0kHz
Edge Delay:	12.5ns
Rise Time:	12.6ns
Fall Time:	14.3ns
Duty Cycle:	50.0 %
Off Time:	50.0us

Figure 4.22 Pulse parameters

5. Remote control

This chapter introduces the remote control basics, remote control interface and configuration methods of 87234 series USB Peak/Avg Power Meter, and briefly introduces the concept and classification of I/O instrument driver library. The purpose is to facilitate users to start to achieve remote control. Specific contents include:

- Remote Control Basics.....41
- Instrument Program Control Port and Configuration.....56
- Basic VISA Interface Programming Method.....56
- I/O Library.....59

5.1 Remote Control Basics

5.1.1 Program Control Interface

Instruments with remote control function generally support three kinds of remote control interface: LAN, GPIB and USB, and the type of port supported by the specific model of instrument is determined by the function of the instrument.

Table 5.1 Remote control interface type and VISA addressing string

Program control interface	VISA address string (Note 1)	Description
LAN (Local Area Network)	Raw socket protocol: TCPIP::Addressograph::port::SOCKET	The controller realizes remote control by connecting the instrument with the network port on the rear panel of the instrument. For the specific protocol, please refer to “5.1.1.1 LAN Interface”.
GPIB (IEC/IEEE Bus Interface)	GPIB::primary address[::INSTR]	The controller realizes remote control by connecting the instrument with the port on the rear panel of the instrument. Follow the bus interface standard IEC 625.1/IEEE 418. For details, please refer to “5.1.1.2 GPIB Interface”.
USB (Universal Serial Bus)	USB::<vendor ID>::<product_ID>::<serial_number>[::INSTR]	Instrument rear panel port. For details, please refer to: “5.1.1.3 USB interface”

5.1 Remote Control Basics

Note 1: VISA, that is, Virtual Instrumentation Software Architecture, is a set of standard software interface function library. Users can use this function library to control instruments via GPIB, RS232, LAN, USB and other interfaces. Users should first install the VISA library on the control computer and use the VISA library to achieve remote instrument control. Please refer to the user manual of the installed VISA library for details.

5.1.1.1 LAN Interface

RJ45 communication cable (shielded or unshielded Category 5 twisted pair) can be used to access 10Mbps/100Mbps/1000Mbps Ethernet for remote control via the control computer in the LAN. For remote control within the LAN, the interface adapter and TCP/IP network protocol have been installed and the corresponding TCP protocol-based network services have been configured.

Generally, the installed network interface adapters have three modes of operation, which are:

- 10 Mbps Ethernet (IEEE802.3);
- 100 Mbps Ethernet (IEEE802.3u);
- 1000Mbps Ethernet (IEEE802.3ab).

The interface adapter automatically matches the appropriate network speed to the link condition. Normally, the length of the cable connecting the instruments should not exceed 100 meters. For more information about Ethernet, please refer to: <http://www.ieee.org>.

Knowledges about the LAN interface are introduced below:

1) IP address

Physical connection of the network should be guaranteed for remote control on the instrument via the LAN. Set the IP address of the instrument to the subnet where the host computer is located. For example, if the IP address of the host computer is 192.168.12.0, the IP address of the instrument should be set to 192.168.12.XXX, where XXX is a value between 1 and 255.

When establishing a network connection, only the IP address is required. The VISA addressing string is as follows:

TCPIP: : host address: port: : SOCKET

Where:

- TCPIP represents the network protocol used;
- host address represents the IP address or host name of the instrument, and is used for identifying and controlling the controlled instrument;
- port identifies the socket port number;
- SOCKET represents the raw network socket resource class.

Example:

To establish a raw socket connection, use:

TCPIP::192.1.2.3::5000::SOCKET

Tips

Method of recognizing multiple instruments in the program control system

If multiple instruments are connected in the network, the individual IP address and related resource string are used to distinguish. The host computer applies its own VISA resource string for instrument identification.

2) Socket communication

The TCP/IP protocol connects the instrument to the network via LAN sockets. As a basic method used in computer network programming, the socket allows applications using different hardware and operating systems to communicate over a network. With this method, two-way communication between the instrument and the computer is realized through ports.

As a software class programmed specially, the socket defines the IP address, device port number and other necessary information for network communication, and integrates some basic operations in network programming. Sockets can be used after installing packaged libraries in the operating system. Two commonly used socket libraries are the Berkeley socket library for UNIX the Winsock library for Windows.

Sockets in the instrument are compatible with Berkeley sockets and Winsock through the application program interface (API). In addition, it is compatible with the API of other standard sockets. When SCPI are used to control the instrument, the socket program established in the program issues the command. The socket port number of the instrument is fixed at 5000.

5.1.1.2 GPIB Interface

GPIB is the only bus designed specifically for instrument control and is still widely used in automated test systems. In order to realize remote control, the host computer should be firstly equipped with GPIB bus card, driver and VISA library. During communication, the host computer addresses the controlled instrument via GPIB address, and the user can change the GPIB address of the controlled instrument to prevent communication failure caused by address conflict in the whole system.

GPIB and its associated interface are defined and described in detail in ANSI/IEEE 488.1-1987 and ANSI/IEEE 488.2-1992. For details of the standards, please refer to the IEEE website:<http://www.ieee.org>.

The following points need to be noted when connecting GPIB:

- The test system through GPIB bus components contains up to 15 devices;
- The total length of the transmission cable should not be more than 20 m or twice the number of instruments in the system;
- In general, the maximum length of the transmission cable between the devices shall not exceed 2 m;
- If multiple instruments are connected in parallel, a "live" cable is required;
- The end of the IEC bus cable shall be connected to the instrument or host computer.

5.1.1.3 USB interface

To implement USB programming, a computer and instrument need to be connected via a USB B-type port with the VISA library installed in advance. VISA automatically detects and configures the

5.1 Remote Control Basics

instrument to establish a USB connection without the need to enter the instrument address string or install a separate driver.

USB Address:

Addressing string format: `USB::::<product ID>::<serial number>[::INSTR]`

Where:

- `<vendor ID>` represents the manufacturer code;
- `<product ID>` represents the instrument code;
- `<serial number>` represents the serial number of the instrument.

Example:

`USB::0x0AAD::0x00C6::100001::INSTR`

0x0AAD: Manufacturer code;

0xC6: Instrument code;

100001: serial number of the instrument.

5.1.2 Message

The messages transmitted on the data cable are divided into the following two categories:

1) Interface message

Interface messages are GPIB bus-specific messages, and only instruments with GPIB bus functionality respond to interface messages. When the host computer sends an interface message to the instrument, the attention cable should be pulled down first, and then the interface message will be transmitted to the instrument through the data cable.

2) Instrument message

For the detailed structure and syntax of the instrument message, see Section [“5.1.3 SCPI Command”](#). The instrument message can be divided into two types as per the transmission direction, namely, command and instrument response. Unless otherwise stated, all remote control interfaces apply instrument message in the same way.

a) Commands:

Commands (programming messages) are messages sent by the host computer to the instrument for remote control of instrument functions and query of status information. Commands are divided into the following two categories:

- Based on the impact on the instrument:
 - Setting commands: change the set state of the instrument, such as reset or setting frequency.
 - Query commands: query and return data, for example: identify the instrument or query the parameter value. Query commands end with the suffix question mark.
- Based on the definition in the standard:
 - Common commands: function and syntax defined by IEEE488.2 for all types of instruments (if implemented) used to implement: management of standard status registers, reset and self-test, etc.
 - Instrument control commands: instrument characteristic commands, used to realize instrument functions, such as setting frequency. The syntax also follows the specifications of SCPI.

b) Instrument response:

Instrument responses (response message and service request) are the query result information sent by the instrument to the computer. Such information includes measurement results, instrument status, etc.

5.1.3 SCPI**5.1.3.1 Introduction to SCPI Command**

SCPI (Standard Commands for Programmable Instruments) are a command set for all instruments established based on Standard IEEE488.2. The main purpose is to make the same function have the same program command to achieve the universality of program control commands.

SCPI consist of a command header and one or more parameters. The command header is separated from the parameters by spaces and contains one or more key fields. A command with direct suffix question mark is a query command. Commands are divided into common commands and instrument commands that have different syntactic structures. SCPI have the following characteristics:

- 1) Program control commands are oriented to test function rather than describing instrument operation;
- 2) Program control commands reduce the repetition of similar test function realization process, and ensure the compatibility of programming.
- 3) Program control messages are defined in layers that are hardware independent of the communication physical layer;
- 4) Program control commands are independent of programming methods and languages. The test program of SCPIs is easy to transplant;
- 5) Program control commands are scalable and can adapt to different scale of measurement control;
- 6) SCPI have been a “living” standard for their scalability.

If you are interested in learning more about SCPI, please refer to:

- IEEE Standard 488.1-1987, IEEE Standard Digital Interface for Programmable Instrumentation. New York, NY, 1998.
- IEEE Standard 488.2-1987, IEEE Standard Codes, Formats, Protocols and Comment Commands for Use with ANSI/IEEE Std488.1-1987. New York, NY, 1998.
- Standard Commands for Programmable Instruments(SCPI) VERSION 1999.0.

For program control command set, classification and description of 87234 series USB Peak/Avg Power Meter, please refer to:

- 1) Program Control Manual Appendix A SCPI Command Quick Reference Table.
- 2) Program Control Manual "3 Program Control Commands";

5.1.3.2 Description of SCPI**1) General terms**

The following terms apply to this section. To better understand the chapters, you shall understand the exact definitions of the terms.

a) Controller

A controller is any computer used to communicate with the SCPI device. A controller may be a PC,

5.1 Remote Control Basics

minicomputer, or a plug-in card on a cage. Some AI devices can also be used as controllers.

b) Device

A device is any device that supports SCPI. Most of the devices are electronic measurement or excitation devices that use GPIB interfaces for communication.

c) Program message

A program message is the combination of one or more SCPI commands that have been correctly formatted. Program messages tell the devices how to measure and output the signals.

d) Response message

A response message is a set of data of specified SCPI formats. Response messages always come from the devices to controllers or listening devices. Response messages tell the controllers about the internal state or measured values of the devices.

e) Command

A command is an instruction that satisfies the SCPI standard. The combination of commands controlling the devices forms a message. In general, a command includes keywords, parameters, and punctuation.

f) Event command

Event-type program control commands cannot be queried. An event command generally has no corresponding front panel key setting, and its function is to trigger an event at a specific time.

g) Query

A query is a special type of command. When a control device is queried, a response message appropriate to the controller syntax requirements is returned. A query statement always ends with a question mark.

2) Command type

There are two types of SCPI: common commands and instrument commands. Common commands, defined by IEEE 488.2, are used to manage macros and status registers and for synchronization and data storage. Because common commands all start with an asterisk, they are easy to be recognized. For example, *IDN?, *OPC, *RST are all common commands. Common commands are not part of any instrument commands, and the instrument interprets them in the same way regardless of the current path setting of the commands.

Instrument commands are easy to be recognized because they contain a colon (:). A colon is used in the beginning of an expression or between two keywords, for example: FREQuency[:CW?]. According to the internal function module of the instrument, instrument commands are divided into sub-sets of corresponding subsystem commands. For example, the power subsystem (:POWer) contains power-related commands, while the status subsystem (:STATus) contains commands for the status control register.

3) Instrument Command Syntax

Table 5.2 Special characters in command syntax

Symbol	Meaning	Example
	The vertical bar between the keyword and the parameter represents multiple options.	[:SENSe]:BANDwidth BWIDth HIGH LOWer BANDwidth and BWIDth are optional, HIGH and LOWer are optional.
[]	A square bracket indicates that the contained keyword or parameter is optional when forming a command. The command will be executed even when such implied keyword or parameter is ignored.	[:SENSe]:BANDwidth? SENSe is optional.
< >	The part in angle brackets indicates that the command is not used in the literal sense. They represent the part that must be contained.	[:SENSe]:FREQuency[:CW FIXed] <val>[unit] In the command, <val> must be replaced by the real frequency [unit] is an omissible unit. For example: FREQ 3.5GHz FREQ 3.5e+009
{ }	The part in braces indicates that the parameter is optional.	MEMory:TABLE:FREQuency <val>{,<val>} For example: MEM:TABL:FREQ 5e7

Table 5.3 Command syntax

Characters, keywords and syntax	Example
Uppercase characters represent the minimum set of characters required to execute a command.	[:SENSe]:FREQuency[:CW FIXed]?, FREQ is the short format part of the command.
Lowercase character of the command is optional; such flexible format is called "flexible listening". See the section "Parameters and Responses of Commands" for more information.	:FREQuency :FREQ,:FREQuency or or :FREQUENCY Either of them is correct.
When a colon is between the two command mnemonics, it moves the current path in the command tree down by one level. For more information, please refer to the command path part in section "Command Tree".	:TRIGger:MODE? TRIGger is the topmost keyword of this command.
If the command contains more than one parameter, adjacent parameters are separated. The parameter is not part of the command path, so it does not affect the path layer.	MEMory:TABLE:FREQuency <val>{,<val>}

5.1 Remote Control Basics

The semicolon is used to separate 2 adjacent commands, without affecting current command path.	:FREQ 2.5GHZ; :POW 10DBM
Blank characters, such as <space> or <tab>, are usually ignored as long as they do not appear between keywords or in keywords. However, you must separate the commands and parameters with blank characters, which does not affect the current path.	:FREQ uency or :POWer :LEVel6.2 is not allowed. :LEVel and 6.2 must be separated by a space, namely, :POWer:LEVel 6.2.

A typical command consists of a keyword prefixed with a colon. The keyword is followed by parameters. The following is an example of a syntax declaration:

```
[ :SOURce]:POWer[:LEVel] MAXimum|MINimum
```

In the example above, the [:LEVel] in the command follow : POWer closely without any space. MINimum|MAXimum immediately following [:LEVel] is the parameter. There is a space between the command and the parameter. Other parts of the syntax expression are described in Table 5.2 and Table 5.3.

4) Command tree

Most remote control programs apply instrument commands. When parsing such commands, SCPI apply a file system-like structure called command tree.

The top command is the root command, or "root" for short. When a command is parsed, follow a specific path to the next level of command according to the tree structure. For example, in :POWer:ALC:SOURce?, : POWer stands for AA, :ALC stands for BB, :SOURce stands for GG, and the entire command path is (:AA:BB:GG).

A software module in instrument software - command interpreter, is responsible for parsing each received SCPI. The command interpreter breaks commands into individual command elements by using a series of rules that distinguish the path of the command tree. After parsing the current command, keep the current command path unchanged. The advantage of this is to parse subsequent commands more quickly and efficiently since that the same command keyword may appear in different paths. After booting or *RST (reseting) the instrument, current command path is reset to root.

5) Command parameters and responses

Table 5.4 Parameter and response types of SCPI

Parameter type	Response data type
Numerical	Real number or integer
Extended numerical	Integer
Discrete	Discrete
Boolean	Digital boolean
String	String
Blocks	Finite-length blocks
	Infinite-length blocks
Non-decimal numeric types	Hexadecimal
	Octal
	Binary

SCPI define different data formats in the use of program and response messages to comply with the principles of "*flexible listening*" and "*precise speaking*". For more information, please refer to IEEE488.2. "*Flexible listening*" means that the formats of the commands and parameters are flexible.

For example, to set the frequency offset status command for USB Peak/Avg Power Meter: `FREQUENCY:OFFSet:STATe ON|OFF|1|0`,

The following command formats are all used to set the frequency offset function to on:

`:FREQUENCY:OFFSet:STATe ON`, `:FREQUENCY:OFFSet:STATe 1`,

`:FREQ:OFFS:STAT ON`, `:FREQ:OFFS:STAT 1`

Each parameter type has one or more corresponding response data types. During query, a data type will be returned for a numerical parameter, and the response data is precise and strict, known as "*precise speaking*."

For example, during query of the power state (`:POWER:ALC:STATe?`), when it is ON, the response data returned is always 1 during query, regardless of whether the previously sent setting command is `:POWER:ALC:STATe 1` or `:POWER:ALC:STATe ON`.

a) Numerical parameters

Numeric parameters can be used in both instrument-specific commands and common commands. A numeric parameter receives all the usual decimal counting methods, including signs, decimals, and scientific notation. If a device only accepts a specified numeric type, such as an integer, it will automatically round up the received numeric parameters.

Examples of numeric parameters:

- 0 No decimal point
- 100 Optional decimal point
- 1.23 Signed bit
- 4.56e<space>3 Index mark e can be followed by a space
- 7.89E-01 Index marker e can be uppercase or lowercase
- +256 Positive lookahead allowed
- 5 Decimal points can be used first

b) Extended numerical parameters

Most measurements related to instrument commands use extended numeric parameters to specify physical quantities. Extended numerical parameters receive all numeric parameters and additional special values. All the extended numeric parameters receive MAXimum and MINimum as parameter values. Whether other special values, such as UP and DOWN, will be received is determined by the ability of the instrument to parse. All effective parameters will be listed in the table of SCPI.

Note: Extended numeric arguments do not apply to common commands or STATus subsystem commands.

Examples of extended numeric parameters:

- 101 Numeric parameter
- 1.2GHz GHz can be used as an index (E009)
- 200MHz MHz can be used as an index (E006)

5.1 Remote Control Basics

-100mV -100 millivolts

10DEG 10 degrees

MAXimum Maximum effective setting

MINimum Minimum effective setting

UP Increase by a step

DOWN Reduce by a step

c) Discrete parameters

When the number of parameter values to be set are finite, they are identified by discrete parameters. Discrete parameters use mnemonics to represent each valid setting. Like program command mnemonics, discrete parameter mnemonics have two formats, long and short, and allow for mixture of upper and lower cases.

In the following examples, discrete parameters and commands are used together.

:TRIGger[:SEQuence]:SOURce BUS|IMMediate|EXTernal

BUS GPIB, LAN, RS-232 trigger

IMMediate Trigger immediately

EXTernal Trigger externally

d) Boolean parameters

A Boolean parameter represents a true or false binary condition, which can only have four possible values.

Boolean parameter examples:

ON Logically true

OFF Logically false

1 Logically true

0 Logically false

e) String parameters

String parameters allow ASCII strings to be sent as parameters. Single quotes and double quotes are used as separators.

The following are example of string parameters:

'This is Valid' "This is also Valid" 'SO IS THIS'

f) Real response data

Most of the test data are of real number type, and their formats can be basic decimal notation or scientific notation, which are supported by most advanced programming languages.

Examples of real number response data:

1.23E+0

-1.0E+2

+1.0E+2

0.5E+0
0.23
-100.0
+100.0
0.5

g) Integer response data

An integer response data is a decimal expression of an integer value containing signed bit. When querying the status register, most of the response data returned are of integer type.

Examples of integer response data:

0	Sign bit optional
+100	Positive lookahead allowed
-100	Negative lookahead allowed
256	No decimal point

g) Discrete response data

Discrete response data are basically the same as discrete parameters, only that the return format of discrete response data is only a short form in uppercase.

Examples of discrete response data:

INTernal	Stabilization mode is internal
EXTernal	Stabilization mode is external
MMHead	Stabilization type is millimeter wave source module

i) Digital Boolean response data

A binary value 1 or 0 is returned as Boolean response data.

j) String response data

String response data and string parameters are alike. The main difference is that the separators of string response data are double quotes instead of single quotes. Double quotes can also be embedded in string response data, and there may be no characters between the double quotes. Here are some examples of string response data:

“This is a string”

“one double quote inside brackets: (“)”

6) Number system of commands

The value of the command can be entered in binary, decimal, hexadecimal or octal format. When using binary, hexadecimal or octal format, a proper identifier is required before the value. The decimal format (the default format) does not require an identifier. When a value is entered without an identifier in front of it, the device will ensure it to be in decimal format. The following list shows the required representations for each format:

- #B indicates that the number is a binary number;
- #H indicates that the number is a hexadecimal number;

5.1 Remote Control Basics

- #Q indicates that the number is an octal number.

The following are various representations of the decimal number 45 in SCPI:

#B101101

#H2D

#Q55

The following example sets the RF output power to 10 dBm (or a value of the equivalent value of the currently selected unit, such as DBUV or DBUVEMF) with a hexadecimal value of 000A.

```
:POW #H000A
```

When using a non-decimal format, a measurement unit, such as DBM or mV, is not used with the value.

7) Command line structure

A command line may contain multiple SCPI. To indicate the end of the current command line, the following methods may be used:

- Enter;
- Enter and EOI;
- EOI and the last data byte.

Commands on the command line are separated by semicolons, and commands belonging to different subsystems begin with a colon. For example:

```
MMEM:COPY "Test1", "MeasurementXY";;HCOP:ITEM ALL
```

The command line contains two commands: the first one belongs to the MMEM subsystem, and the second belongs to the HCOP subsystem. If adjacent commands belong to the same subsystem with repeated command path, they can be expressed in abbreviation. For example:

```
HCOP:ITEM ALL;;HCOP:IMM
```

The command line contains two commands: both of them belong to the HCOP subsystem, with the same first level. Therefore, the second command can start from the next level of HCOP, and the colon for starting the command can be omitted. It can be abbreviated as follows:

```
HCOP:ITEM ALL;IMM
```

5.1.4 Command Sequence and Synchronization

IEEE488.2 defines the difference between overlapping and sequential commands:

- Sequential commands are sequences of commands that are executed continuously. Each command is usually executed faster;
- An overlapping command is one that is not executed automatically before the next command is executed. It usually takes longer to process overlapping commands, and programs are allowed to process other events synchronously during the period.

Even if there are multiple setting commands on a command line, they may not be executed in the order they were received. To ensure that commands are executed in a certain order, each command must be sent on a separate command line.

Example: the command line contains setting and query commands

If multiple commands on a command line contain query commands, the query results are

unpredictable. A fixed value is returned for the following command:

:FREQ:STAR 1GHZ;SPAN 100;;FREQ:STAR?

Returned value: 1000000000 (1GHz)

The following commands return variable values: :FREQ:STAR 1GHZ;STAR?;SPAN 1000000

The returned result can be current initial frequency value of the instrument before such command is sent, since the host program will not execute the commands one by one until all command messages are received. If the host program executes after receiving the command, the returned result may also be 1GHz.

Tips

Setting commands are sent separately from query commands

General rules: The setting command and query command shall be sent in different program control messages, so as to ensure the returned result of the query command is correct.

In order to prevent overlapping execution of commands, multithreading or commands *OPC, *OPC? or *WAI may be applied, which are executed only after the hardware setting is completed. During programming, the computer may force a period of time to synchronize certain events. The descriptions are shown below:

- The controller program applies multi-threading

Multi-threading is used to wait for command completion and synchronization between the UI and program control, that is, to wait for *OPC? Completion in separate threading without interfering GUI or program threading execution;

- The application of the three commands in synchronous execution is shown in the table below:

Table 5.5 Command syntax

Method	Action	Programming method
*OPC	After the command is executed, set it in the operation completion bit of the ESR register.	Set to ESE BIT0; Set to SRE BIT5; Send overlapping commands and *OPC; Wait for service request (SRQ) Service request represents that the overlapping command has been executed.
*OPC?	Stop executing the current command until it returns 1. The command is returned only when it is in the operation completion bit of the ESR register, indicating that the previous command has been processed.	Terminate processing of the current command before executing other commands, and send the command directly after the current command.
*WAI	Before the execution of *WAI, wait for all commands to be sent before proceeding with unfinished commands.	Terminate processing of the current command before executing other commands, and send the command directly after the current command.

5.1 Remote Control Basics

5.1.5 Status Reporting System

The status report system stores all operation status information and error information of current instrument. They are stored in status registers and error queues respectively, and can be queried through a remote control interface.

5.1.5.1 Structure of Status Register

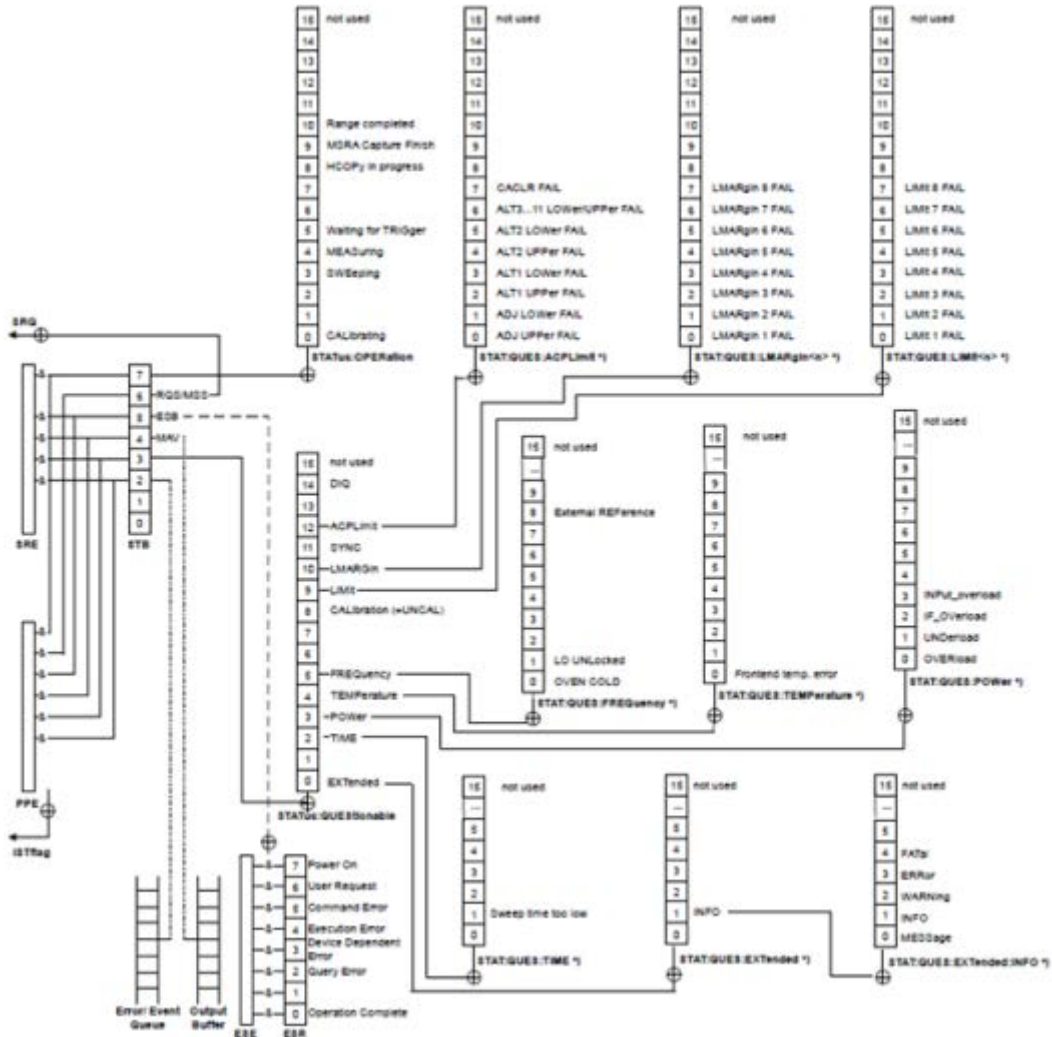

Fig.5.1 Hierarchical structure of the status register

Status registers are described by classification below:

1) STB, SRE

The status byte (STB) register and its related mask register - service request enable register (SRE), comprise the top register of the status reporting system. STB saves the general working state of the instrument by collecting the information of lower registers.

2) ESR, SCPI status register

STB receives information from the following registers:

- The value of the event status register (ESR) and the event status enable (ESE) mask register;

□ SCPI status register includes: STATus:OPERation and STATus:QUEStionable registers (SCPI definition),

which contain the specific operation information of the instrument. All SCPI status registers have the same internal structure

(For details, see 2.1.5.2 “SCPI status register structure”, please refer to Section 2.1.5.2 "Structure of SCPI Status Register"

of the program control manual).

3) IST,PPE

Similar with SRQ, IST (“Individual Status”) marks a separate bit consisting of all statuses of the instrument. The associated parallel poll enable register (PPE) determines the STB data bits for IST marking.

4) Output buffer

It stores the messages returned by the instrument to the master. It does not belong to the status report system, but determines the MAV position value of the STB.

For details on the registers mentioned above, see [“2.1.5 Status report system” of the program control manual.](#)

Please refer to the hierarchical structure of status register shown in Figure 5.1.

Tips

SRE, ESE

SRE may be used as the enable part of STB. Similarly, ESE may be used as the enable part of ESR.

5.1.5.2 Application of Status Reporting System

The status reporting system is used to monitor the status of one or more instruments in a test system. In order to correctly realize the function of the status reporting system, the controller in the test system must receive and evaluate the information of all instruments. Standard methods used include:

- 1) Service request (SQR) initiated by the instrument;
- 2) Serial query of all instruments in the bus system, initiated by the controller in the system, in order to find the initiator of the service request and the reason;
- 3) Parallel query of all instruments;
- 4) Program command to query the status of specific instruments;

For specific operation methods, see [“2.1.5 Status report system application”](#) of the program control manual.

5.1.6 Programming Precautions

1) Please initialize the instrument status before changing settings

When setting the instrument remotely, first initialize the instrument status (for example, send “*RST”), and then implement the required status setting.

5.2 Instrument Program Port and Configuration

2) Command sequence

In general, setting commands and query commands should be sent separately. Otherwise, the returned value of query commands will change with the current order of instrument operation.

3) Fault response

Service requests can only be initiated by the instrument. The controller program in the test system should guide the instrument to initiate service request actively when there is an error, and then enter corresponding interrupt service program for processing.

4) Error queue

Each time the controller program processes a service request, it should query the error queue of the instrument instead of the status register for a more precise cause of the error. Especially in the test phase of the controller program, the error queue should be frequently queried to obtain the error command sent by the controller to the instrument.

5.2 Instrument Program Port and Configuration

The USB program control system controls the instrument based on the USBTMC protocol.

5.2.1 Connection Establishment

Use the USB cable to connect the 87234 series USB Peak/Avg power meter to an external controller (computer).

5.2.2 Interface Configuration

The VID and PID of this instrument are 0x04B4 and 0x1010 respectively, and the serial number is marked on the instrument. These three interface information are fixed and not user configurable.

5.3 Basic VISA interface programming

Take the following as an example to describe the basic method for realizing instrument program control programming via the VISA library. Take the C++ language as an example.

5.3.1 Installing VISA Library

To achieve remote control, it is first required to install the VISA library. VISA library packages the underlying transmission functions of VXI, GPIB, LAN and USB interfaces to make it convenient for users to recall directly. The programming interface supported by the USB Peak/Avg power meter is: USB. These interfaces, combined with the VISA library and programming language, allow remote control of the USB Peak/Avg Power Meter.

5.3.2 Generate Global Variables

Start by generating global variables that other program modules will recall, such as instrument handle variables. The following example programs should contain the following global variables:

```
ViSession iDevHandle;
```

```
ViSession iDefaultRM;
```

```
const char rgcDevRsc[MAX_RSC_LEN] = "USB0::04B4::1010::2019001::0::INSTR";
```

```
const int iTmo = 5000;
```

Where, the constant `rgcDevRsc` represents the instrument descriptor, "USB0" represents the controller, "04B4" represents the vendor ID of the instrument, 1010 is the product ID, and 2020001 is the product serial number.

If the instrument is controlled via the GPIB interface and the GPIB address is "20", then the value of

the variable is

```
const char rgcDevRsc[MAX_RSC_LEN] = "GPIB0::20::INSTR";
```

If the instrument is controlled via a LAN socket interface with IP address 192.168.1.1 and port number 5025, then the value of the variable is

```
const char rgcDevRsc[MAX_RSC_LEN] = "TCPIP0::192.168.1.1::5025::SOCKET";
```

If the instrument is controlled via the LAN interface with IP address 192.168.1.1, then the value of the variable is

```
const char rgcDevRsc[MAX_RSC_LEN] = "TCPIP0::192.168.1.1::INSTR";
```

5.3.2 Initialize Controller

```
/******
```

The following example shows the way to open and establish the communication connection between the VISA library and instrument (with instrument descriptor specified).

//Initialize the controller: open the default explorer and return the instrument handle iDevHandle.

```
*****/
```

```
void InitController()
{
    ViStatus iStatus;
    iStatus = viOpenDefaultRM(&iDefaultRM);
    iStatus = viOpen(iDefaultRM, rgcDevRsc, VI_NULL, VI_NULL, &iDevHandle);
}
```

5.3.3 Initialize the instrument

```
/******
```

The following examples show how to initialize the default state of the instrument and empty the status register.

```
*****/
```

```
void InitDevice()
{
    ViStatus iStatus;
    ViUInt32 uiRetCnt;
    iStatus = viWrite(iDevHandle, "*CLS\n", strlen("*CLS\n"), &uiRetCnt); //Status Reset
    iStatus = viWrite(iDevHandle, "*RST\n", strlen("*RST\n"), &uiRetCnt); //Instrument Reset
}
```

5.3.4 Send Setting Command

```
/******
```

5.3 Basic VISA interface programming

The following example shows how to set the frequency of the 87234 series USB Peak/Avg Power Meter.

```

/*****/
void SimpleSettings()
{
    ViStatus iStatus;
        ViUInt32 uiRetCnt;
        //Set the frequency to 128MHz
        iStatus = viWrite(iDevHandle, "FREQ 1.2e8\n", strlen("FREQ 1.2e8\n"), &uiRetCnt);
}

```

5.3.5 Read the State of Measuring Instrument

The following examples show how to read the set state of the instrument.

```

/*****/
void ReadSettings()
{
    ViStatus iStatus; //Status
        ViUInt32 uiRetCnt; //read the returned bytes
        char rgcBuf[256]; //Temporary buffer
        char* pcCmd = NULL; //Command pointer

        //QueryFreq
        pcCmd = "FREQ?\n";
        iStatus = viWrite(iDevHandle, pcCmd, strlen(pcCmd), &uiRetCnt);
        Sleep(10);
        iStatus = viRead(iDevHandle, rgcBuf, sizeof(rgcBuf), &uiRetCnt);
        //Print debugging information
    printf("frequency %s", rgcBuf);
}

```

5.3.6 Command Synchronization

The following examples illustrate the methods for command synchronization with sweep process.

```

/*****/
void SweepSync()

```

```

{
    ViStatus iStatus; //Status
        ViUInt32 uiRetCnt; //read the returned bytes
        ViEventType eType; //Event Type
        ViEvent eEvent; //Event
        int iStat; //Status word
        char rgcOpcOk[256]; //OPC string
        char* pcCmd = NULL; //Command pointer

        /*****/

        /* The command INITiate[:IMMEDIATE] is used to start single sweep (when continuous sweep
        is OFF, INIT:CONT OFF)*/

        /* Only at the end of single sweep can the next command in the command buffer be
        executed */

        /*****/

        pcCmd = "INIT:CONT OFF\n";
        iStatus = viWrite(iDevHandle, " pcCmd ", strlen(pcCmd), &uiRetCnt);
        //Method 1 for waiting for the sweep to end: use *WAI
        pcCmd = "ABOR;INIT:IMM;*WAI\n";
        iStatus = viWrite(iDevHandle, " pcCmd ", strlen(pcCmd), &uiRetCnt);
        //Method 2 for waiting for the sweep to end: use *OPC?
        pcCmd = "ABOR;INIT:IMM; *OPC?\n";
        iStatus = viWrite(iDevHandle, " pcCmd ", strlen(pcCmd), &uiRetCnt);
        iStatus = viRead(iDevHandle, rgcOpcOk, 2, &uiRetCnt); //wait for *OPC to return "1"

        //Main program continues.....
}

```

5.4 I/O library

5.4.1 Overview of I/O Library

I/O library is a pre-written software library for instruments, known as instrument driver. As a software between the computer and the instrument hardware, it consists of the function library, utility program, tool kit, etc. It is a combination of a series of software code modules and corresponds to operation of a plan, such as configuring the instrument, reading from the instrument, writing to the instrument and triggering the instrument, etc. Residing in the computer, it is the bridge and link between the computer and the instrument. By providing a high-level modular library for convenient programming, users no longer need to learn the complex low-level programming protocol for a specific instrument. Application of instrument driver is the key to develop test and measurement applications quickly.

5.4 I/O library

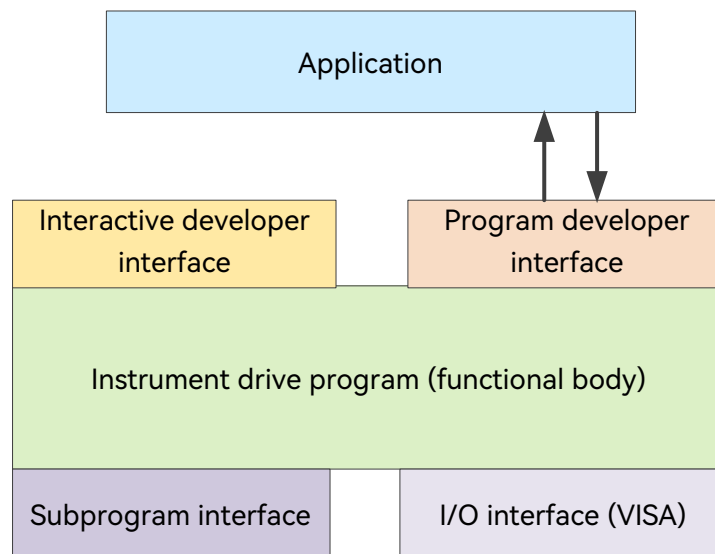

Figure 5.2 Structure model of instrument driver

Functionally, a universal instrument driver generally consists of five parts: functor, interactive developer interface, programmer interface, subprogram interface and I/O interface, as shown in Fig.5.2.

The details are as follows:

- 1) Functor. As the main function part of the instrument driver, it may be understood as its framework program;
- 2) Interactive developer interface. Application development environment that supports instrument driver development is usually provided with graphical interactive developer interface for user convenience. For example, in Labwindows/CVI, the function panel is an interactive developer interface. In the function panel, each parameter of the instrument driver function is represented as a graphical control;
- 3) Programmer interface. It is a software interface for the application to recall instrument driver function, such as dynamic link library file.dl of instrument driver in Windows system;
- 4) I/O interface. It completes the actual communication between the instrument driver and the instrument. The bus specific I/O software, such as GPIB and RS-232, or the common standard I/O software used across multiple buses, VISA I/O, may be used;
- 5) Subprogram interface. It is a software interface for the instrument driver to access other support libraries, such as databases, FFT functions, etc. The subprogram interface is used when the instrument driver needs to recall other software modules, operating systems, program code libraries and analysis function libraries to complete its task.

5.4.2 Installation and Configuration of I/O Library

Along with the application in test field, it has gone through different development stages from traditional instrument to virtual instrument. In order to solve the interchangeability of instruments and reusability of test program in automatic test system, instrument driver has gone through different development processes. IVI (Interchangeable Virtual Instruments) driver is relative popular and common at present. Based on IVI specification, it defines a new instrument programming interface, inserts the class driver and VPP architecture onto the VISA to make the test application and instrument hardware completely independent, adds such unique functions as instrument simulation, range sensing and status cache, improves the operation efficiency of the system, and realizes instrument exchange.

There are two types of IVI driver: IVI-C and IVI-COM, where the latter adopts the form of COM API based on the component object model (COM) of Microsoft, and the former adopts the form of C API based on ANSI C. Both types are designed according to the instrument class defined in the IVI specification and have the same application development environment, including Visual Studio, Visual Basic, Agilent VEE, LabVIEW, CVI/LabWindows, etc.

Two types of driver should be provided at present to meet the needs of different users in different development environments. IVI driver of the USB Peak/Avg Power Meter is developed with Nimbus Driver Studio and directly generates IVI-COM and IVI-C driver and program installation package. For specific installation and configuration, please refer to the attached documentation of the control card and I/O library you selected.

IVI driver after installation are divided into IVI inherent function group and instrument function group (basic function group and extended function group). Specific function classification, functions and attributes are shown in the help document of the driver.

Tips

Port configuration and IO library installation

Before using the computer to control the USB Peak/Avg Power Meter, please make sure you have the necessary ports and I/O libraries installed and configured correctly.

6 Troubleshooting and after-sales services

This chapter will show you how to find problems and accept after-sales service, and explain error message of the instrument.

If you encounter any problem when operating the 87234 series USB Peak/Avg Power Meter or want to buy relevant components or accessories, we can provide you with complete after-sales services.

Generally, causes of problems include hardware, software or user maloperation. In case of any problem, please contact us in time. If the USB Peak/Avg power meter is within the warranty period, we will repair it for free as per the provisions specified in the warranty bill. Otherwise, we will charge maintenance costs as per the contract requirement.

- Working Principles.....63
- Troubleshooting.....64
- Error Messages.....65
- Repair Methods.....65

6.1 Working Principles

The section introduces the basic working principle and hardware function block diagram of the 87234D/E/F/L USB Peak/Avg Power Meter, so as to facilitate users' understanding on functions of the USB Peak/Avg Power Meter and solving problems encountered during operation.

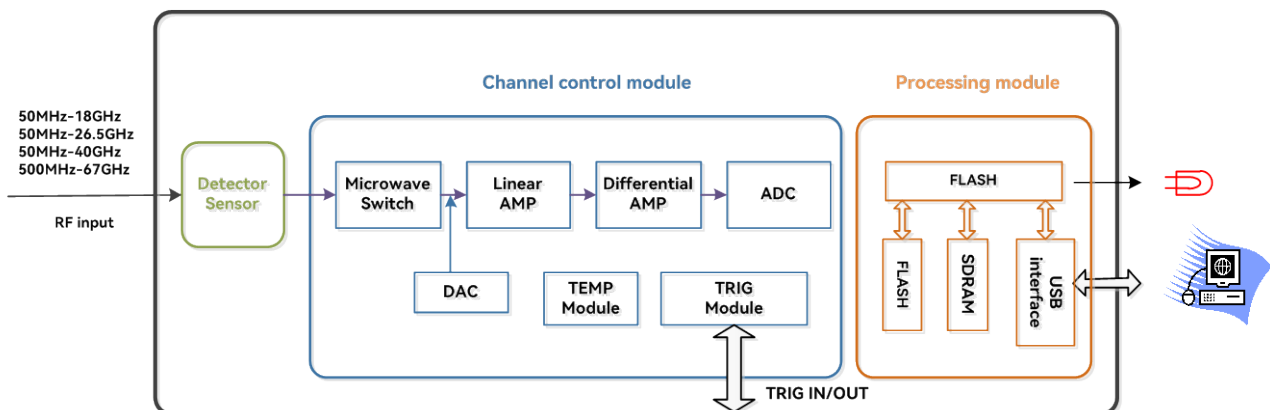

Figure 6.1 Instrument hardware block diagram

In this project, diode is used as the power sensor. When the USB Peak/Avg power meter is used to measure the peak envelope of pulse power, its internally balanced dual diode detector first detects the input microwave pulse modulation signal and converts it into two-way pulse modulation envelope signal. Two microwave switches on the front of the channel conditioning board control the USB Peak/Avg power meter to either a measurement state or an internal zeroing state. When the switch is turned on for power measurement, the positive and negative detector signals are linearly amplified and enter two differential amplifiers with high and low ranges, respectively, and then enter the dual-channel ADC for sampling. Internal zeroing is performed when the switch is turned off. In this project, the real-time sampling technology is used to realize data acquisition. The 16-bit dual-channel ADC performs analog-to-digital conversion at the rate of 80Msamples/s of the master clock, and the rate at which the converted data is latched and written into DDR3 is controlled by the sampling clock given by the sampling rate generator of the time base unit circuit. The sampled data stored in DDR3 is read out by the main processor at the end of each acquisition cycle and further processed by digital filtering, rapid calibration and compensation to obtain waveform data for display. The USB Peak/Avg power meter supports high data transfer rates of up to 480Mb/s via the

6.2 Troubleshooting and debugging

USBTMC-compliant Universal Serial Bus to upload measurement results to the host computer for display.

In this project, the function of desktop peak power meter is implemented in one USB Peak/Avg power meter, so the compensation of power data is directly for the instrument, which will not produce the error generated by the use of the probe and power meter host in the traditional power measurement solution. Therefore, the calibration source is no longer needed and the calibration operation is no longer required, which can reduce the size and power consumption, make the use more convenient and test more efficient. The calibration data performed on the instrument is stored in FLASH. In the implementation of temperature compensation algorithm, the processor uses a thermistor located near the diode sensor to continuously monitor the product temperature.

The USB Peak/Avg Power Meter developed in this project are divided into four frequency bands, which are 50MHz-18GHz, 50MHz-26.5GHz, 50MHz-40GHz and 500MHz-67GHz, respectively, with the same circuit board and structural parts of the instrument. The frequency bands are divided through the detector components to realize the serialization of products, and make the products easy to produce and maintain, with high reliability and stability.

6.2 Troubleshooting and debugging

Tips

Troubleshooting and instructions

This section introduces the way on how to judge and handle failures (if any) of the 87234 series USB Peak/Avg Power Meter, and feed them back to the manufacturer as accurately as possible if necessary for quick solution.

The following failures and debugging methods are listed as per function types.

6.2.1 USB Device not Found

If the USB device is not found in the computer's Device Manager after power-up, please follow the steps listed below for checking:

Step 1. Confirm whether the USB cable is connected properly and check whether the USB power supply is working properly;

Step 2. Confirm whether multiple USB devices are connected, using a USB HUB with an external power supply if necessary;

Step 3. Confirm whether the host have the device VISA library and drivers correctly installed.

6.2.2 State Indicator not ON

Check whether the USB2.0 interface of the host computer is working properly, replace other USB interfaces to observe whether the indicator is working, or use other devices such as mouse, keyboard, U disk, etc. to verify that the USB interface is powered properly. If it is abnormal, check the external lines for any failure. After troubleshooting, power on the instrument again. If it is confirmed that it is caused by the power supply of the instrument itself, the product should be sent back to the manufacturer for repair.

6.2.3 Unexpected Phenomenon

In the process of use, there are many reasons for the unexpected phenomenon. Refer to the following test procedures to determine the cause of the problem with the instrument. Usually these tests can solve the problem or determine the cause of the problem clearly.

- Check whether the mechanical connection of USB cable is correct and whether the electrical characteristics are compatible;
- When problems occur after certain settings, check the actions taken to make sure all settings are correct. If the test is completed, check that the measurement results match the signal under test and that the performance specifications of the instrument are met.
- When the instrument shows unexpected results, if you are not sure whether the settings made are correct, replug it and then set it according to the signal under test and test requirements.

6.3 Error Messages

During actual use, the system will automatically provide error messages if it is not operated properly or configured correctly. Users can roughly determine the type of problem based on error prompts and take appropriate measures to troubleshoot or decide to return for repair.

In the User Power Test panel, click the Error List icon to view the recent error messages.

For detailed descriptions of error messages, please refer to the *Program Control Manual of 87234 Series USB Peak/Avg Power Meter*.

6.4 Method to Obtain After-sales Services

6.4.1 Contact us

In case of any failure to the 87234 series USB Peak/Avg Power Meter, check and save the error message, analyze possible causes, and refer to the methods provided in “[6.2 Troubleshooting and debugging](#)” for preliminary troubleshooting. If the problem cannot be solved, contact the service and consultation center of the Company as per the contact information provided below and provide us with the error collected. We will coordinate with you to solve the problem as soon as possible.

Contact information:

Service Consultation: 0532--86889847 400--1684191

Technical support: 0532--86880796

Quality Supervision: 0532--86886614

Fax: 0532--86889056

Website: www.ceyear.com

Email: techbb@ceyear.com

Address: No. 98, Xiangjiang Road, Qingdao Economic & Technological Development Zone, Shandong Province

Postal code: 266555

6.4.2 Package and mailing

In case of any failure to the 87234 series USB Peak/Avg Power Meter that is difficult to be eliminated, contact us by phone or fax. If it is confirmed that the USB Peak/Avg power meter has to be returned for repairing, pack it with the original packing materials and case by following the steps below:

- 1) Prepare a detailed description of the failure of the power meter and put it into the package along with the power meter.
- 2) Pack the power meter with the original packing materials, so as to minimize possible damage;
- 3) Place cushions at the four corners of the outer packing carton, and place the instrument in the

6.4 Method to Obtain After-sales Services

outer packing carton.

- 4) Seal the opening of the packing carton with adhesive tape and reinforce the packing carton with nylon tape.
- 5) Specify text like “Fragile”! Do not touch! Handle with care!” and so on.
- 6) Please consign it as precision instruments.
- 7) Keep a copy of all shipping documents.

Notice

Precautions for packaging USB Peak/Avg Power Meter

Using other materials for packing USB Peak/Avg Power Meter may damage the instrument. Never use polystyrene beads to pack the instrument due to two reasons, that is, they cannot provide sufficient protection on the instrument, and they can be sucked in to the instrument fan by the static electricity generated, resulting in instrument damage.

Tips

Instrument package and transportation

Please follow carefully the precautions described in “[3.2.1 Unpacking](#)” when transporting or handling the instrument (for example, damage occurred during delivery).

7 Technical indicators and testing methods

The section introduces the technical indicators and testing methods of the 87234 series USB Peak/Avg Power Meter.

➤ Statement.....	67
➤ Product Features.....	67
➤ Technical Indicators.....	68
➤ Option Information.....	70
➤ Additional information.....	71
➤ Performance Indicator Test.....	72

7.1 Statement

The test conditions for all indicators are under the temperature of $23^{\circ}\text{C}\pm 5^{\circ}\text{C}$ (half hours after startup), unless otherwise specified. The additional instrument information is to facilitate users to understand more clearly the instrument performance that is not contained in the technical indicator range. Key word descriptions are shown below:

Technical specification (spec): Place the calibrated instrument in the working environment of $0^{\circ}\text{C} - 50^{\circ}\text{C}$ for at least 2h, and then warm it up for 30 min., so as to ensure its performance (including the measurement uncertainty), unless otherwise specified. All data in the document are technical specifications, unless otherwise specified.

Typical value (Typ): It indicates 80% of the instruments can reach typical performance, which is not a guarantee, and excludes uncertainty factors during the measurement. It is valid only at the room temperature (about 25°C).

Nominal value (nom): It indicates such performances as the expected average performance, designed performance features or those that cannot be tested by limited test means, for example, the $50\ \Omega$ connector. Products marked with nominal values are not included in the warranty, and such values are taken at the room temperature (about 25°C).

Measured value (meas): It indicates the performance feature measured during the design phase for comparing with the expected performance, for example, amplitude drifting change with time. Note: Such data is not a guarantee, which is also taken at the room temperature (about 25°C).

7.2 Product features

Table 7.1 Product features

Product features	
Display	Host computer display
Operation interface language	Chinese/English
Power supply requirement	+5V, 500mA
Working temperature range	$0^{\circ}\text{C} \sim 50^{\circ}\text{C}$
Storage temperature range	$-40^{\circ}\text{C} \sim +70^{\circ}\text{C}$
Working humidity	When the temperature is lower than 10°C , the humidity is not controlled;

7.3 Technical Indicators

	When temperature range is 10°C–30°C, the relative humidity is (5–95)%; When temperature range is 30°C– 40°C, the relative humidity is (5–75)%; When the temperature is above 40 °C, the relative humidity is (5–45)%;	
Elevation	0–4600m	
Weight	< 0.3kg	
Boundary dimension (Width×Height×Depth)	87234D	141.1mm×52.0mm×34.0mm
	87234E	133.9mm×52.0mm×34.0mm
	87234F	124.7mm×52.0mm×34.0mm
	87234L	124.7mm×52.0mm×34.0mm
Vibration	Random vibration: frequency 5 - 100Hz, power spectral density 0.015g ² /Hz; frequency 100 - 137Hz, slope -6dB; frequency 137 - 350Hz, power spectral density 0.0075g ² /Hz; frequency 350 - 500Hz, slope -6dB; frequency 500Hz, power spectral density 0.0039g ² /Hz.	
Reliability requirement	MTBF (θ_0) ≥5000h	
Recommended calibration cycle	12 months	

7.3 Technical Indicators

Table 7.2 Technical indicators

Technical indicators		
Frequency range	87234D	50MHz ~ 18GHz
	87234E	50MHz ~ 26.5GHz
	87234F	50MHz ~ 40GHz
	87234L	500MHz ~ 67GHz
Power range	Normal@ModeMode	-30dBm ~ +20dBm (50MHz - 500MHz)
		-35dBm ~ +20dBm (≥500MHz)
	Average Mode ¹	-45dBm ~ +20dBm
Max input power	+23dBm (average power)	
	+30dBm (peak power, duration <1us)	
Rise/fall time	≤13ns ²	
Sampling rate	80MSamples/sec, continuous sampling	
VBW	≥30MHz	
Single capture bandwidth	≥30MHz	
Min. pulse width	50ns	

Average power measurement accuracy³	87234D	±0.20dB (±4.5%)	
	87234E	±0.25dB (±6.0%)	
	87234F	±0.30dB (±6.7%)	
	87234L	±0.33dB (±7.9%)	
Maximum capture length	1s (down frequency)		
	1.2ms (maximum sampling rate)		
Maximum pulse repetition frequency	10MHz		
Max Voltage Standing Wave Ratio	87234D	1.20 (50MHz-2GHz)	
		1.26 (2GHz-18GHz)	
	87234E	1.20 (50MHz-2GHz)	
		1.26 (2GHz-18GHz)	
		1.35 (18GHz-26.5GHz)	
	87234F	1.20 (50MHz-2GHz)	
		1.26 (2GHz-18GHz)	
		1.35 (18GHz-26.5GHz)	
		1.50 (26.5GHz-40GHz)	
	87234L	1.20 (500MHz-2GHz)	
		1.26 (2GHz-18GHz)	
		1.35 (18GHz-26.5GHz)	
		1.50 (26.5GHz-40GHz)	
		1.70 (40GHz-67GHz)	
	Calibration uncertainty	87234D	4.0% (50MHz-10GHz)
			4.5% (10GHz-18GHz)
87234E		4.2% (50MHz-1GHz)	
		4.5% (1GHz-18GHz)	
		5.3% (18GHz-26.5GHz)	
87234F		4.2% (50MHz-1GHz)	
		4.5% (1GHz-18GHz)	
		5.3% (18GHz-26.5GHz)	
		5.8% (26.5GHz-40GHz)	
87234L		4.5% (500MHz-18GHz)	
		5.3% (18GHz-26.5GHz)	
		5.8% (26.5GHz-40GHz)	
	7.0% (40GHz-67GHz)		
Connector	87234D	N-Type(m)	

7.4 Option Information

	87234E	3.5mm(m)
	87234F	2.4mm(m)
	87234L	1.85mm(m)

NOTE:

1. It is recommended to conduct zeroing after startup, significant temperature change or a long time since the last zeroing. In the Average Mode, external zeroing should be performed and it should be ensured that the power meter and RF source are isolated.
2. It is effective when the frequency is greater than or equal to 500MHz and the video bandwidth is turned off.
3. It is effective when the power range is -15dBm ~ +20dBm, the frequency is greater than or equal to 500MHz, and the SWR of the device under test is less than 1.20. In the free operation mode, the average value is set to 32.

7.4 Option Information

Table 7.3 Option Information

Options	Description
87234-H01	Power cable, 4.5m
87234-H02	Trigger cable, 4.5m
87234-H03D	Commercial Calibration Certificate, 87234D
87234-H03E	Commercial Calibration Certificate, 87234E
87234-H03F	Commercial Calibration Certificate, 87234F
87234-H03L	Commercial Calibration Certificate, 87234L
87234-H04	English kit
87234-H05A	Hard suitcase (one set can be carried)
87234-H05B	Hard suitcase (two sets can be carried)
87234D-EWT1	Extended Warranty Service
87234E-EWT1	Extended Warranty Service
87234F-EWT1	Extended Warranty Service
87234L-EWT1	Extended Warranty Service

7.5 Additional information

7.5.1 Time base/trigger

Table 7.4 Time base/trigger

Time base/trigger	
Time base	2ns/div-100ms/div
Internal trigger (typical)	-20dBm ~ +20dBm
External TTL trigger input	> 2.4V (high level)
	< 0.7V (low level)
	50Ω (Impedance)
External TTL trigger output	> 2.4V (high level)
	< 0.7V (low level)
	50Ω (Impedance)
Trigger delay	± 1.0s (maximum)
Trigger Holdoff	1us ~ 1s

7.5.2 Input/output

Table 7.5 Input/output

I/O interface		
RF input	87234D	N-Type(m)
	87234E	3.5mm(m)
	87234F	2.4mm(m)
	87234L	1.85mm(m)
Trigger input	TTL level compatible, MMCX connector	
Trigger output	TTL level compatible, MMCX connector	
Video output	0-1V, 50Ω impedance, MMCX connector	
Program control interface	USB2.0 interface, USB-TMC compatible	
Maximum measurement speed	50,000 readings per second	

7.6 Performance characteristics test

7.5.3 Host computer

Table 7.6 Host computer

Host computer	
Operating system	Windows 10 32-bit and 64-bit Windows 7 32-bit and 64-bit Windows XP Linux
Hardware	Processor: 1GHz or more (2GHz or more recommended) Memory: 2GB or more (4GB or more recommended) Hard disk space: 1.0GB or more Display: 1280 x 1024 or better

7.6 Performance characteristics test

7.6.1 Recommended testing method

7.6.1.1 Frequency range

Description: There are four models of USB Peak/Avg power meter, namely 87234D, 87234E, 87234F and 87234L, and the frequency ranges are 50MHz-18GHz, 50MHz-26.5GHz, 50MHz-40GHz and 500MHz-67GHz respectively. The calibration uncertainty of USB Peak/Avg power meter in this frequency range should meet the requirements respectively. The calibration uncertainty index test covers the whole frequency band of the corresponding power meter, so it can be determined that the frequency range index meets the requirements. See 7.6.1.9 Testing for calibration uncertainty for specific testing methods.

7.6.1.2 Power range

Description: This test uses the test method of comparing with standard power meter to verify whether the power test range index of USB Peak/Avg power meter meets the requirements.

Test block diagram:

Test block diagram as shown in Figure 7.1.

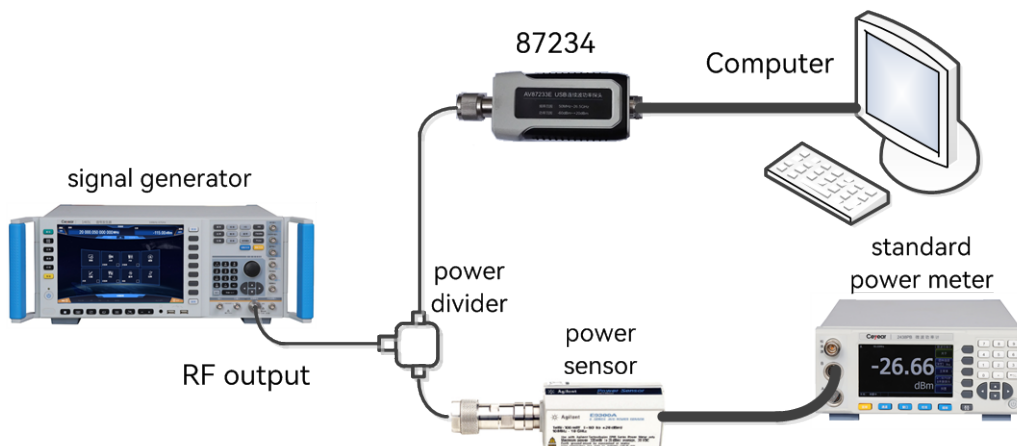

Figure 7.1 Frequency range test

Test procedure:

- 1) The USB Peak/Avg power meter under test is connected to the computer via USB cable, and the standard power meter is mated to a power probe covering the frequency band, warmed up for at least 30 minutes and then zeroed, and connected in accordance with Figure 7.1;
- 2) Set the signal generator to Continuous Wave mode with a frequency of 1 GHz and output power as required in Table 7.7 Average Power Range Test Form;
- 3) The average power measurements are performed with the USB Peak/Avg power meter under test and the standard power meter, respectively. The USB Peak/Avg power meter is measured in the Normal mode from -35dBm ~ +20dBm and in the Average Mode from -45dBm ~ -35dBm. Set the average times according to Table 7.8 and record the measured value P1 of the USB Peak/Avg power meter under test and the measured value P0 of the standard power meter. The measurement error is ΔP (dB) = P1-P0, and its value should meet the allowable error value required by the index in Table 7.7.

Note: The range of error values is determined by performing calculations based on the following equation:

$$U_C = 2 \left[\sqrt{\left[\frac{\text{Max}(\rho_{DUT}) \times \text{Max}(\rho_{USB})}{\sqrt{2}} \right]^2 + \frac{(U_M + U_Z + U_S)^2}{4}} \right] \quad (\text{Equation 1})$$

Where, $\text{Max}(\rho_{DUT})$ is the maximum reflection coefficient of the device under test and $\text{Max}(\rho_{USB})$ is the maximum reflection coefficient of this instrument;

U_M is the USB Peak/Avg power meter measurement uncertainty, up to ± 0.11 dB;

Zeroing uncertainty U_Z = Accuracy of zeroing/measured power value;

U_S is the calibration uncertainty.

Notes: 1. When measuring power below -20dBm, turn off the internal zero calibration and trigger output, and perform external zeroing with the USB Peak/Avg power meter isolated from the input signal.

2. In Figure 7.1, if there is no power divider, the USB Peak/Avg power meter under test and the standard power probe can be connected to the output of the signal generator for testing respectively.

Table 7.7 Power Range Test Form

	Power point (dBm)	Standard power meter Measured value P0 (dBm)	Power meter under test Measured value P1 (dBm)	Error value ΔP (dB)	Allowable error value (dB)
87234D	+20				± 0.20
	0				± 0.20
	-15				± 0.20
	-35				± 1.65
	-45				± 2.47
87234E	+20				± 0.25
	0				± 0.25
	-15				± 0.25

7.6 Performance characteristics test

87234F	-35				±1.65
	-45				±2.47
	+20				±0.30
	0				±0.30
	-15				±0.30
	-35				±1.65
87234L	45				±2.47
	+20				±0.33
	0				±0.33
	-15				±0.33
	-35				±1.65
	-45				±2.47

Table 7.8 Test average setting

Power dynamic range	Resolution			
	1	2	3	4
20dBm ~ 0dBm	1	1	2	16
0dBm ~ -10dBm	1	4	16	32
-10dBm ~ -20dBm	1	16	64	512
-20dBm ~ -30dBm	4	64	256	512
-30dBm ~ -45dBm	64	512	512	512

Note: 1. If the measurement is in dBm or dB, the four resolutions are 1, 0.1, 0.01, and 0.001.

7.6.1.3 Rise/fall time

Description: This test uses the pulse modulated signal from the test signal generator of USB Peak/Avg power meter under test to verify that the rise/fall time of the USB Peak/Avg power meter meets the requirements.

Test block diagram:

Test block diagram as shown in Figure 7.2.

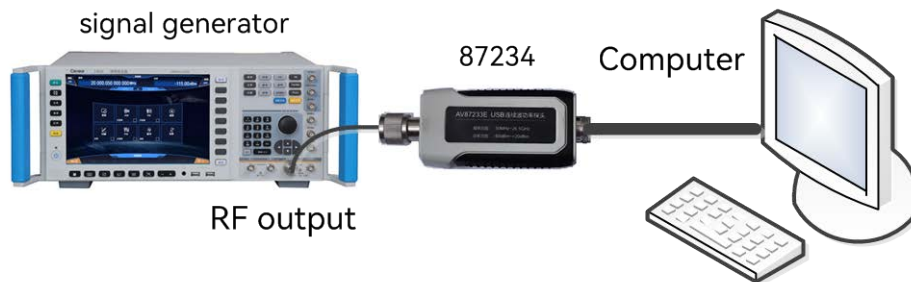

Figure 7.1 Test on rise/fall time

Test procedure:

- 1) The USB Peak/Avg power meter under test is connected to the computer via USB cable, warmed up for at least 30 minutes and then zeroed, and connected in accordance with Figure 7.2;
- 2) Set the signal generator to Pulse Modulation mode, with pulse period of 10us, and pulse width of 5us, set the frequency to 1GHz, and set the output power according to the requirements in Table 7.9 Rise/Fall Time Test Form;
- 3) Open the trace display window of USB Peak/Avg power meter under test, set the frequency to 1GHz, set the horizontal scale to 1us/div, select the internal trigger mode for the trigger source, and enable the auto level. Set the averaging times in accordance with Table 7.8 and record the pulse rising/falling edge readings t_R measured automatically by the USB Peak/Avg power meter under test;
- 4) The rise/fall time of the USB Peak/Avg power meter under test is calculated by the following formula, and the actual value t_r (ns) is recorded. The actual value should meet the requirements of the rise/fall time index.

$$t_r = \sqrt{t_R^2 - t_S^2} \times (1 - 30\%) \quad (\text{Equation 2})$$

where, t_r - the actual rise/fall time of the USB Peak/Avg power meter under test, in ns;

t_R - the reading of the rise/fall time of the USB Peak/Avg power meter under test, in ns;

t_S - the rise/fall time of the signal generator output pulse, in ns.

Notes: 1. When the rise time of USB Peak/Avg power meter is 13ns, the error is 30%.

Table 7.9 Rise/ fall time test form

	Requirements (ns)	Reading value t_R (ns)		Actual value t_r (ns)	
		Rise	Fall	Rise	Fall
87234D	≤13ns				
87234E	≤13ns				
87234F	≤13ns				
87234L	≤13ns				

7.6.1.4 Minimum pulse width

Description: This test verifies whether the minimum pulse width index of the pulse envelope signal measured by the USB Peak/Avg power meter under test meets the requirements.

Test block diagram:

Test block diagram as shown in Figure 7.2.

Test procedure:

- 1) The USB Peak/Avg power meter under test is connected to the computer via USB cable, warmed up for at least 30 minutes and then zeroed, and connected in accordance with Figure 7.2;
- 2) Set the signal generator to Pulse Modulation mode, with pulse period of 1us, and pulse width of 50us, set the frequency to 1GHz, and set the output power to 5dBm;

7.6 Performance characteristics test

3) Open the trace display window of USB Peak/Avg power meter under test, set the frequency to 1 GHz, enable the auto level mode, and set the averaging times in accordance with Table 7.8;

4) After the measurement is stable, read the pulse width measured by the USB Peak/Avg power meter under test. The automatic measurement error of pulse width should not exceed 13ns.

7.6.1.5 Average power measurement accuracy

Description: This test uses the test method of comparing with standard power meter to verify whether the average power test range index of USB Peak/Avg power meter meets the requirements.

Test block diagram:

Test block diagram as shown in Figure 7.1.

Test procedure:

1) The USB Peak/Avg power meter under test is connected to the computer via USB cable, and the standard power meter is connected to the power probe of the corresponding frequency band, zeroed after warming up for at least 30 minutes, and is connected in accordance with Figure 7.1;

2) Set the signal generator to Continuous Wave mode with a frequency of 1 GHz and output power as required in Table 7.10 Average Power Measurement Accuracy Test Form;

3) Continuous-wave average power measurements are performed with the USB Peak/Avg power meter under test and the standard power meter, respectively, and the averaging times are set according to Table 7.8. The measured value P1 of the USB Peak/Avg power meter under test and the measured value P0 of the standard power meter are recorded. The measurement error is ΔP (dB) = P1-P0, and its value should meet the allowable error value required by the index in Table 7.10.

Note: In Figure 7.1, if there is no power divider, the USB Peak/Avg power meter under test and the standard power probe can be connected to the output of the signal generator for testing respectively.

Table 7.10 Average Power Measurement Accuracy Test Form

	Power point (dBm)	Standard power meter Measured value P0 (dBm)	Power meter under test Measured value P1 (dBm)	Error value ΔP (dB)	Allowable error value (dB)
87234D	+20				±0.20
	0				±0.20
	-15				±0.20
87234E	+20				±0.25
	0				±0.25
	-15				±0.25
87234F	+20				±0.30
	0				±0.30
	-15				±0.30
87234L	+20				±0.33
	0				±0.33
	-15				±0.33

7.6.1.6 Maximum pulse repetition rate

This test verifies whether the repetition rate index of the pulse envelope signal measured by the USB Peak/Avg power meter under test meets the requirements.

Test block diagram:

Test block diagram as shown in Figure 7.2.

Test procedure:

- 1) The USB Peak/Avg power meter under test is connected to the computer via USB cable, warmed up for at least 30 minutes and then zeroed, and connected in accordance with Figure 7.2;
- 2) Set the signal generator to Pulse Modulation mode, with pulse period of 100us, and pulse width of 50us, set the frequency to 1GHz, and set the output power to 5dBm;
- 3) Open the trace display window of USB Peak/Avg power meter under test, set the frequency to 1 GHz, enable the auto level mode, and set the averaging times in accordance with Table 7.8;
- 4) After the measurement is stable, read the pulse signal frequency measured by the USB Peak/Avg power meter under test. The measurement error of pulse repetition frequency shall not exceed $\pm 2\%$.

7.6.1.7 Max. VSWR

Description: This test uses a vector network analyzer to test whether the VSWR of the USB Peak/Avg power meter meets the requirements.

Test block diagram:

Test block diagram as shown in Figure 7.3.



Figure 7.3 VSWR test

Test procedure:

- 1) The USB Peak/Avg power meter under test is connected to the vector network analyzer via USB cable, and warmed up for at least 30 minutes. as shown in Fig. 7.3:
- 2) Set the vector network analyzer port 1 to S11 mode and set the corresponding frequency range according to the USB Peak/Avg Power Meter under test.
- 3) Operate according to the user manual of the vector network analyzer, and use the corresponding calibration kit to calibrate the single port S11 standing wave of the vector network analyzer in the corresponding band;
- 4) Connect in accordance with Figure 7.3. The absolute value of the S11 curve displayed by the vector network analyzer is the input port VSWR of the USB Peak/Avg power meter, and the test value should meet the index requirements.

7.6 Performance characteristics test

7.6.1.8 Calibration Uncertainty

Description: This test uses the test method of comparing with standard power meter to verify whether the index meets the requirements.

Test block diagram:

Test block diagram as shown in Figure 7.1.

Test procedure:

- 1) The USB Peak/Avg power meter under test is connected to the computer via USB cable, and the standard power meter is connected to the power probe of the corresponding frequency band, zeroed after warming up for at least 30 minutes, and is connected in accordance with Figure 7.1;
- 2) Set the signal generator to Continuous Wave mode with output power of 0 dBm and set the frequency as required in Table 7.11 Calibration Uncertainty Test Form;
- 3) Measure the signal generator output using a standard power meter, record the measured value P0, measure the signal generator output using the USB Peak/Avg power meter under test, record the measured value P1, calculate the deviation $\Delta P = P1 - P0$ and record it;
- 4) The final calibration uncertainty is selected as the maximum value of deviation, which should be within the index requirements.

Note: The logarithmic and linear conversion equation of calibration uncertainty is

$$U = (10^{\Delta P/10} - 1) \times 100\% \quad (\text{Equation 3})$$

where, U is the linear error and ΔP is the logarithmic error.

Note: In Figure 7.1, if there is no power divider, the USB Peak/Avg power meter under test and the standard power probe can be connected to the output of the signal generator for testing respectively.

Table 7.11 Calibration Uncertainty Test Form

	Test frequency point	Standard power meter Measured value P0 (dBm)	Power meter under test Measured value P1 (dBm)	Error value ΔP (dB)	Allowable error value (dB)
87234D	50MHz				±0.17
	1GHz				±0.17
	5GHz				±0.17
	10GHz				±0.17
	15GHz				±0.20
	18GHz				±0.20
87234E	50MHz				±0.18
	1GHz				±0.18
	5GHz				±0.20
	10GHz				±0.20
	18GHz				±0.20

7.6 Performance characteristics test

	20GHz				±0.23
	26.5GHz				±0.23
87234F	50MHz				±0.18
	1GHz				±0.18
	10GHz				±0.20
	18GHz				±0.20
	26.5GHz				±0.23
	30GHz				±0.25
	40GHz				±0.25
	87234L	500MHz			
1GHz					±0.20
10GHz					±0.20
18GHz					±0.23
26.5GHz					±0.23
30GHz					±0.25
40GHz					±0.25
50GHz					±0.30
60GHz					±0.30
67GHz					±0.30
Note: 4.0% converted to log 0.17dB, 4.2% converted to log 0.18dB, 4.5% converted to log 0.20dB, 5.3% converted to log 0.23dB, 5.8% converted to log 0.25dB, and 7.0% converted to log 0.30dB.					

7.6 Performance characteristics test

7.6.2 Record chart of performance characteristics test

Table 7.12 87234D USB Peak/Avg power meter test records

Test site: _____ Test environment: _____ Test time: _____

Equipment number under test: _____ Test Personnel: _____

No.	Test Item	Unit	Standard Requirement	Test results	Conclusions		
1	Interface	/	N-Type(m)				
2	Appearance	/	The surface shall be smooth and clean, free of obvious mechanical damage, deposition or damage, the structure shall be complete, and control parts shall be installed properly and reliably, with operation flexibility.				
3	Functional normality	/	The indicator flashes after the instrument is connected to the computer with the driver installed via USB cable, and the soft panel is opened to identify the instrument.				
	Main Functions	Average power measurement function	/	Soft panel displays average power measurement results			
		Pulse debugging signal measurement function	/	Soft panel displays pulse modulation signal envelope waveform			
		CCDF statistical analysis function	/	Soft panel shows CCDF statistical analysis results			
		Internal and external trigger function	/	Internal and external trigger function can be set			
USB programmable function		/	Can execute the commands of the host computer				
4	Performance features	Frequency range	GHz	0.05 ~ 18			
		Power range	dBm	Normal mode	-30 ~ +20 (50MHz - 500MHz)		
					-35 ~ +20 (≥500MHz)		
				Average mode	-45 ~ +20		
		Max input power	/	Average power	+23dBm		
				Peak power	+30dBm (peak duration <1us)		
Rise/fall time	ns	≤13ns					

7.6 Performance characteristics test

		Min. pulse width	ns	50			
		Average power measurement accuracy	dB	±0.20			
		Maximum pulse repetition frequency	MHz	10			
		Max Voltage Standing Wave Ratio	/	1.20	50MHz ~ 2GHz		
				1.26	2GHz ~ 18GHz		
		Calibration uncertainty	/	4.0% (0.17dB)	50MHz ~ 10GHz		
				4.5% (0.20dB)	10GHz ~ 18GHz		
5	Color		/	Black and white			

7.6 Performance characteristics test

Table 7.13 87234E USB Peak/Avg power meter test records

Test site: _____ Test environment: _____ Test time: _____

Equipment number under test: _____ Test Personnel: _____

No.	Test Item		Unit	Standard Requirement		Test results	Conclusions	
1	Interface		/	3.5mm(m)				
2	Appearance		/	The surface shall be smooth and clean, free of obvious mechanical damage, deposition or damage, the structure shall be complete, and control parts shall be installed properly and reliably, with operation flexibility.				
3	Functional normality		/	The indicator flashes after the instrument is connected to the computer with the driver installed via USB cable, and the soft panel is opened to identify the instrument.				
	Main Functions	Average power measurement function	/	Soft panel displays average power measurement results				
		Pulse debugging signal measurement function	/	Soft panel displays pulse modulation signal envelope waveform				
		CCDF statistical analysis function	/	Soft panel shows CCDF statistical analysis results				
		Internal and external trigger function	/	Internal and external trigger function can be set				
USB programmable function		/	Can execute the commands of the host computer					
4	Performance features	Frequency range	GHz	0.05-26.5				
		Power range	dBm	Normal mode	-30 ~ +20 (50MHz - 500MHz)			
					-35 ~ +20 (≥500MHz)			
				Average mode	-45 ~ +20			
		Max input power	/	Average power	+23dBm			
				Peak power	+30dBm (peak duration <1us)			
		Rise/fall time	ns	≤13ns				
Min. pulse width	ns	50						

7.6 Performance characteristics test

		Average power measurement accuracy	dB	±0.25			
		Maximum pulse repetition frequency	MHz	10			
		Max Voltage Standing Wave Ratio	/	1.20	50MHz ~ 2GHz		
				1.26	2GHz ~ 18GHz		
				1.35	18GHz ~ 26.5GHz		
		Calibration uncertainty	/	4.2% (0.18dB)	50MHz ~ 1GHz		
				4.5% (0.20dB)	1GHz ~ 18GHz		
				5.3% (0.23dB)	18GHz ~ 26.5GHz		
5	Color		/	Black and white			

7.6 Performance characteristics test

Table 7.14 87234F USB Peak/Avg power meter test records

Test site: _____ Test environment: _____ Test time: _____

Equipment number under test: _____ Test Personnel: _____

No.	Test Item	Unit	Standard Requirement	Test results	Conclusion		
1	Interface	/	2.4mm(m)				
2	Appearance	/	The surface shall be smooth and clean, free of obvious mechanical damage, deposition or damage, the structure shall be complete, and control parts shall be installed properly and reliably, with operation flexibility.				
3	Functional normality	/	The indicator flashes after the instrument is connected to the computer with the driver installed via USB cable, and the soft panel is opened to identify the instrument.				
	Main Functions	Average power measurement function	/	Soft panel displays average power measurement results			
		Pulse debugging signal measurement function	/	Soft panel displays pulse modulation signal envelope waveform			
		CCDF statistical analysis function	/	Soft panel shows CCDF statistical analysis results			
		Internal and external trigger function	/	Internal and external trigger function can be set			
USB programmable function		/	Can execute the commands of the host computer				
4	Performance features	Frequency range	GHz	0.05 ~ 40			
		Power range	dBm	Normal mode	-30 ~ +20 (50MHz - 500MHz)		
					-35 ~ +20 (≥500MHz)		
				Average mode	-45 ~ +20		
		Max input power	/	Average power	+23dBm		
				Peak power	+30dBm (peak duration <1us)		
		Rise/fall time	ns	≤13ns			
Min. pulse width	ns	50					

7.6 Performance characteristics test

		Average power measurement accuracy	dB	±0.30			
		Maximum pulse repetition frequency	MHz	10			
		Max Voltage Standing Wave Ratio	/	1.20	50MHz ~ 2GHz		
				1.26	2GHz ~ 18GHz		
				1.35	18GHz ~ 26.5GHz		
				1.50	26.5GHz ~ 40GHz		
		Calibration uncertainty	/	4.2% (0.18dB)	50MHz ~ 1GHz		
				4.5% (0.20dB)	1GHz ~ 18GHz		
				5.3% (0.23dB)	18GHz ~ 26.5GHz		
				5.8% (0.25dB)	26.5GHz ~ 40GHz		
5	Color		/	Black and white			

7.6 Performance characteristics test

Table 7.15 87234L USB Peak/Avg power meter test records

Test site: _____ Test environment: _____ Test time: _____

Equipment number under test: _____ Test Personnel: _____

No.	Test Item	Unit	Standard Requirement	Test Results	Conclusion		
1	Interface	/	1.85mm(m)				
2	Appearance	/	The surface shall be smooth and clean, free of obvious mechanical damage, deposition or damage, the structure shall be complete, and control parts shall be installed properly and reliably, with operation flexibility.				
3	Functional normality	/	The indicator flashes after the instrument is connected to the computer with the driver installed via USB cable, and the soft panel is opened to identify the instrument.				
	Main Functions	Average power measurement function	/	Soft panel displays average power measurement results			
		Pulse debugging signal measurement function	/	Soft panel displays pulse modulation signal envelope waveform			
		CCDF statistical analysis function	/	Soft panel shows CCDF statistical analysis results			
		Internal and external trigger function	/	Internal and external trigger function can be set			
USB programmable function		/	Can execute the commands of the host computer				
4	Performance features	Frequency range	GHz	0.5-67			
		Power range	dBm	Normal mode	-35 ~ +20 (≥500MHz)		
				Average mode	-45 ~ +20		
		Max input power	/	Average power	+23dBm		
				Peak power	+30dBm (peak duration <1us)		
		Rise/fall time	ns	≤13ns			
		Min. pulse width	ns	50			

7.6 Performance characteristics test

		Average power measurement accuracy	dB	±0.33			
		Maximum pulse repetition frequency	MHz	10			
		Max Voltage Standing Wave Ratio	/	1.20	50MHz ~ 2GHz		
				1.26	2GHz ~ 18GHz		
				1.35	18GHz ~ 26.5GHz		
				1.50	26.5GHz ~ 40GHz		
				1.70	40GHz ~ 67GHz		
		Calibration uncertainty	/	4.5% (0.20dB)	50MHz ~ 18GHz		
				5.3% (0.23dB)	18GHz ~ 26.5GHz		
				5.8% (0.25dB)	26.5GHz ~ 40GHz		
				7.0% (0.30dB)	40GHz ~ 67GHz		
5	Color		/	Black and white			

7.6 Performance characteristics test

7.6.3 Recommended instrument for performance characteristics test

Table 7.16 Recommended instrument for performance characteristics test

No.	Instrument	Main technical indicators	Recommended model
1	Signal Generator	Frequency range: 250kHz-67GHz Power range: -110dBm ~ +20dBm	E8257D 1465 Series
2	Power meter	Frequency range: 10MHz ~ 67GHz Power range: -70dBm ~ +20dBm	N1913A/N1914A
3	Power probe	Frequency range: 10MHz ~ 67GHz Power range: -70dBm ~ +20dBm	E9300A, N8488A
4	Vector network analyzer	Frequency range: 10Hz ~ 67GHz	E8361C 3672E
5	Oscilloscope	Bandwidth: 100MHz	TDS1012
6	USB tester	Voltage: 3-9V Current: 0-3A	UT658B
7	Caliper	Minimum division value $\geq 0.01\text{mm}$	
8	Counter scale	Minimum division value $\geq 1\text{g}$	

Note*: It can be replaced by test equipment with the same performance characteristics.



Focus on measurement
Explore the future

CEYEAR TECHNOLOGIES CO., LTD

Tel: +86 532 86896691

Email: sales@ceyear.com

<http://www.ceyear.com>