

LabSat Real-Time+

LabSat Real-Time+ is a cost effective, low latency, compact GNSS Hardware-in-the-Loop (HIL) testing solution.

- Real-time GNSS signal generation
- Low latency from position input to GNSS RF output
- Compatible with all major simulators
- Compact yet powerful for portable testing
- Easy to use, plug-and-play solution

Real-time position control for HIL applications

For HIL testing and development of GNSS enabled control systems, **LabSat Real-Time+** generates a live, dynamic GNSS RF signal that corresponds to positional data supplied by a HIL simulator. Any change in the HIL simulator position produces a corresponding change in the GNSS signal, with very low latency.

The use of **LabSat Real-Time+** makes GNSS simulation with low latency and real-time control, a realistic solution for developers requiring an affordable method of efficient, accurate HIL testing.

What scenarios can it simulate?

LabSat Real-Time+ can simulate a GNSS RF signal anywhere in the world using GPS L1, Galileo E1, BeiDou B1 and GLONASS L1 constellations.

It has two available RF channels that can simulate up to three satellite constellations simultaneously - GPS L1 and Galileo E1 share the same centre frequency so can therefore be simulated using a single RF channel.



How does it work?

LabSat Real-Time+ combines a **LabSat Real-Time+** simulator, a **LabSat Syncbox**, an Intel NUC PC and **SatGen Real-Time+** simulation software.

1. Positional data from the device under test (DUT) within the HIL system is supplied to the **LabSat Syncbox** via an ethernet or serial connection as an NMEA stream at a rate of up to 100 Hz.
2. To ensure consistent, low-latency performance, the **LabSat Syncbox** receives a standardised 100 Hz sync pulse from the **LabSat Real-Time+** simulator. It then interpolates the NMEA data into a 100 Hz stream aligned with the sync pulse (regardless of the original NMEA input rate) and feeds it into the factory configured Intel NUC PC running **SatGen Real-Time+** simulation software.
3. **SatGen Real-Time+** simulation software then generates the corresponding scenario, and outputs an RF signal via the **LabSat Real-Time+** simulator back in to the DUT in the HIL system.
4. When simulating a single constellation scenario, the latency is within 100 ms from NMEA data input to GNSS RF output.

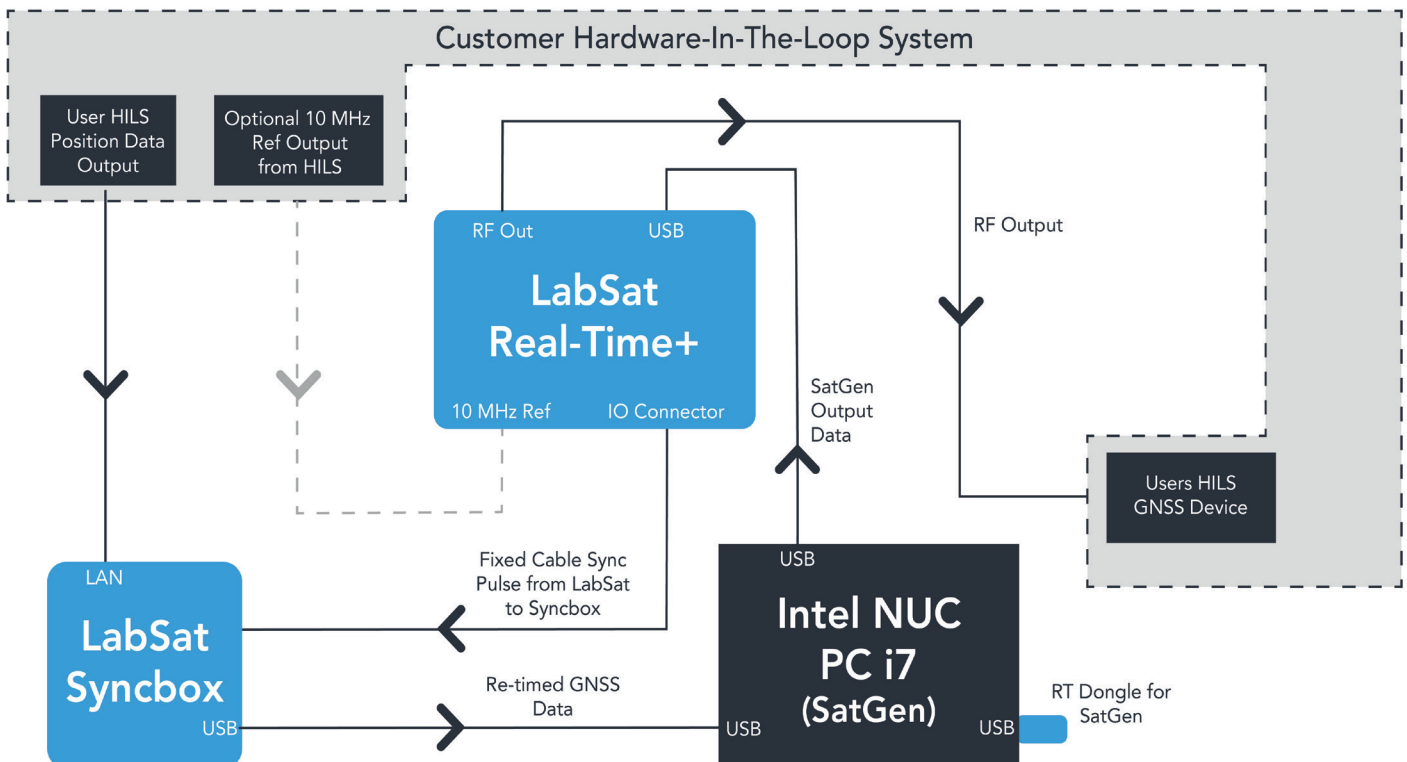

Robust Real-Time Setup



- 1 RT Dongle for SatGen
- 2 User Input Data LAN
- 3 Sync Pulse
- 4 Re-timed Sync Data
- 5 SatGen Output
- 6 GNSS RF Output
- 7 User Data Input (RS232)



Applications

In recent years, the market for GNSS guided applications has seen rapid expansion in many sectors including agriculture, UAVs, transportation and industrial. Real-world testing and development are often expensive and time consuming which is where HIL testing can provide a more efficient solution.

LabSat Real-Time+ is ideal for any HIL testing that requires a real-time GNSS signal to provide location and timing to the device under test.

Product Specifications

Constellations	GPS L1, GLONASS L1, BeiDou B1, Galileo E1
Output Signal Level	Fixed -83 dBm
RF Channels	2
RF Channel Centre Frequencies	Selectable
Sampling Frequency	16.368 MHz
Number of Satellites Observed	Up to 24 (when simulating GPS and/or Galileo)
Quantisation	1 or 2 bit (I & Q)
Data Format	I & Q
Media Storage Included	External hard disk only
Active Antenna Voltage Supply	3.3 V
Frequency Stability	± 2.5 ppm TCXO / ± 0.5 ppm OCXO (optional)
Temperature Stability	± 0.05 ppm TCXO / ± 0.01 ppm OCXO (optional)
Operating Voltage	8 V to 30 V DC

Intel NUC Specifications

Base CPU Frequency	2.80 GHz
Turbo Boost	4.70 GHz Turbo
Cores and Threads	Cores 4, Threads 8
Max Memory	64 GB
Networking	Intel Wi-Fi 6 AX201, 2.5 GB Ethernet
I/O	3x USB 3.2 Type-A, 1x USB 2.0 Type-A