

Keysight Technologies

# Scienlab Charging Discovery System

EMC Series for EV Test

SL1040A-EMC



## Table of Contents

Introduction .....	3
SL1040A-EMC Charging Discovery System EMC Series for EV Test.....	4
SL1040A-301 Communication Module PLC.....	11
SL1040A-302 Communication Module GB/T .....	12
SL1040A-303 Communication Module CHAdeMO .....	12
EV charging adapters (EMC conform).....	13
SL1040A-601 EV charging adapter AC Type 1.....	13
SL1040A-602 EV charging adapter AC Type 2.....	13
SL1040A-605 EV charging adapter GB/T AC .....	13
SL1040A-603 EV charging adapter CCS Type 1 .....	13
SL1040A-604 EV charging adapter CCS Type 2.....	13
SL1040A-606 EV charging adapter GB/T DC .....	13
SL1040A-607 EV charging adapter CHAdeMO .....	13
Service Options .....	15
Project Management and Technical Consulting Service.....	15
Installation Service.....	15
Commissioning Test .....	16
Productivity Assistance.....	16

## Introduction

This data sheet describes the EMC optimized Charging Discovery System (CDS) for EV testing.

The EMC Series for EV Test is intended for use inside an anechoic chamber for immunity and emission tests (conducted or radiated) of electric vehicles, during AC or DC charging.

Due to the special EMC shielded design and built-in low-noise components, the emission of the CDS is reduced to a minimum level. This enables EMC testing of EVs under real charging conditions without undesired test environment interference. Furthermore, the EMC series of the CDS is immune to external electro-magnetic fields and can be placed close to the specimen during immunity tests (see section “EMC performance”).

For EVSE test, see separate data sheet “Scienlab Charging Discovery System - EMC series for EVSE test”.

The EMC variant is fully software compatible with the portable CDS. However, Keysight designed it for reliable charging emulation, without extended fault injection, required for conformance testing.

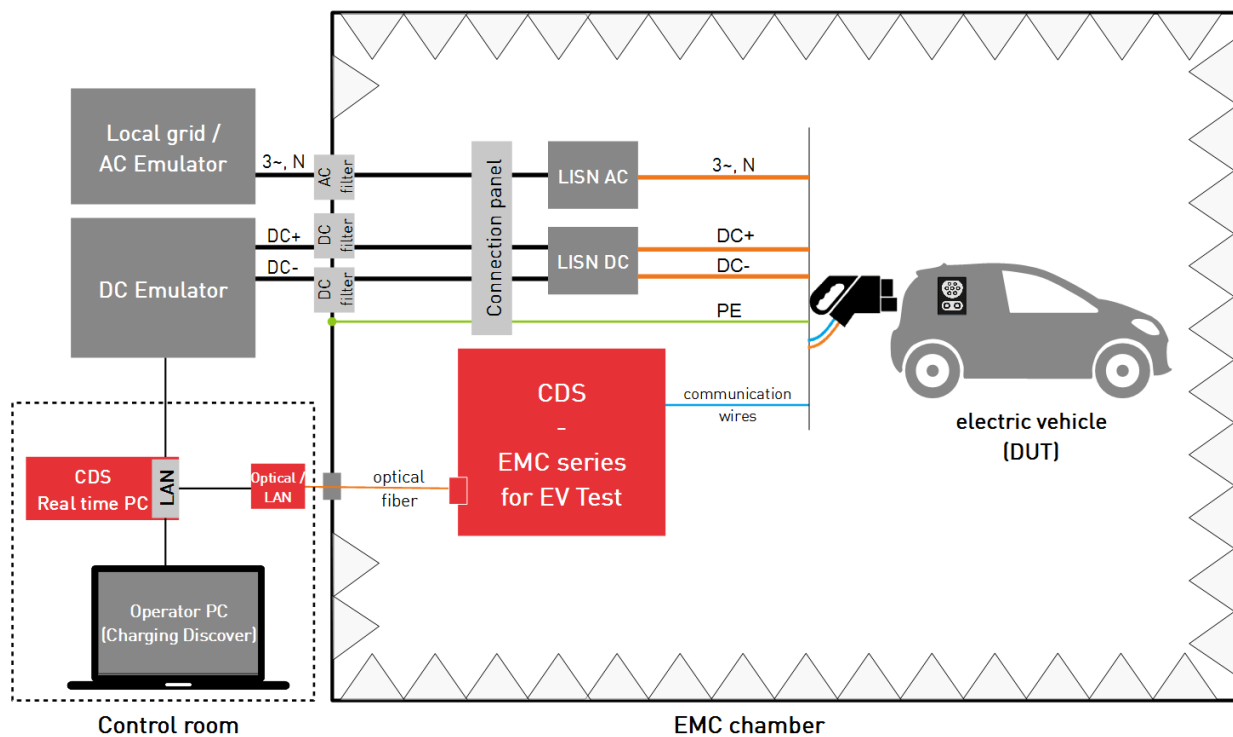

Figure 1: Exemplary architecture of test environment EV test

**Note:** This data sheet describes the essential product and its system options. If you need a full solution, contact your local Keysight Sales and Service office for a statement of work proposal including required periphery, installation, and other services.

## SL1040A-EMC Charging Discovery System EMC Series for EV Test

Keysight designed the shielded CDS variant to be used for EMC compliance and homologation tests. This item is the main module which can be extended by optional communication modules (see SL1040A-301, SL1040A-302, SL1040A-303).

Figure 2 below shows a three-dimensional view of the shielded housing. During operation the housing is permanently closed with a lid.

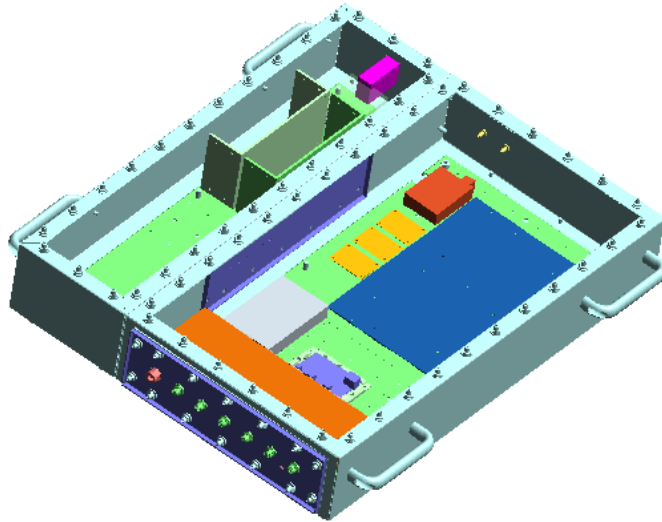

Figure 2: 3D drawing of EMC optimized Charging Discovery System

### General Functions

- Reliable, interoperable emulation of the EVSE charging communication controller (SECC); verified by thousands of successful charging sessions with almost all available EV brands & models.
- Easy configuration of charging protocol and operating point through Windows control software Charging Discover (see also corresponding data sheet) or optionally via customer automation software (using the CDS remote interface)
- Integrated PWM emulation for Control Pilot circuit of the EVSE signal generator with adjustable positive/negative amplitude, frequency and duty cycle
- Integrated emulation of the Proximity Pilot circuit
- Real-time capable control PC with high system performance and low dead times. Note: IPC is placed typically outside of the EMC chamber (see section “Real-time PC”)
- Portable shielded “galvanized metal” case with grounding contact springs
- Isolated interface to Real-time PC via Optical Data Converter (see section “Optical Data Converter”)
- Direct support of Scienlab/Keysight power sources and sinks

## Standards and directives

CDS supports the following charging communication standards:

The basic functions include:

- AC charging mode according to IEC 61851-1 (PWM)
- AC charging mode according to SAE J1772 (PWM)
- AC charging mode according to GB/T 18487 (PWM)

The following are available when ordering communication modules:

- DC fast charging mode according to DIN SPEC 70121 & ISO 15118
- AC charging mode according to ISO 15118
- DC fast charging mode according to GB/T 27930
- DC fast charging mode according to CHAdeMO

## EMC performance

- EMC optimized case for emission and immunity testing
- Immunity of CDS rated up to 200 V/m (30 Mhz to 1 Ghz)

Figures 3, 4, and 5 show sample EMC measurement results to illustrate the CDS emission performance:

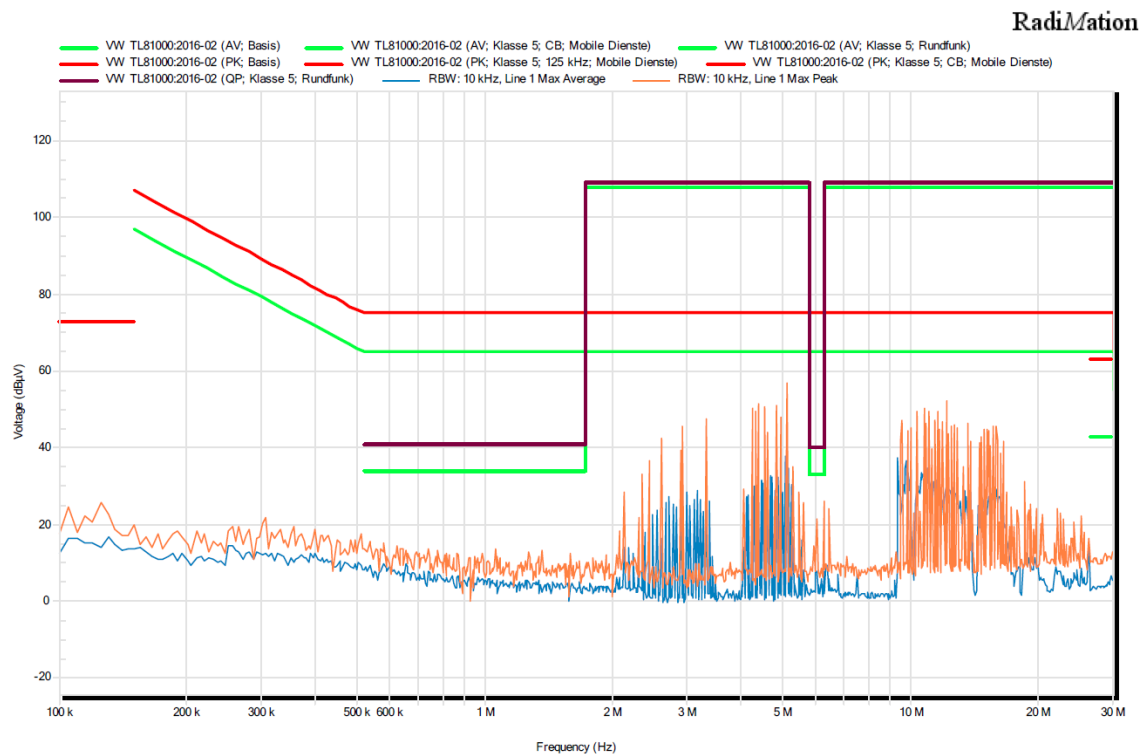

Figure 3: Results of conducted emission test between 100 kHz and 30 MHz, with active PLC modem

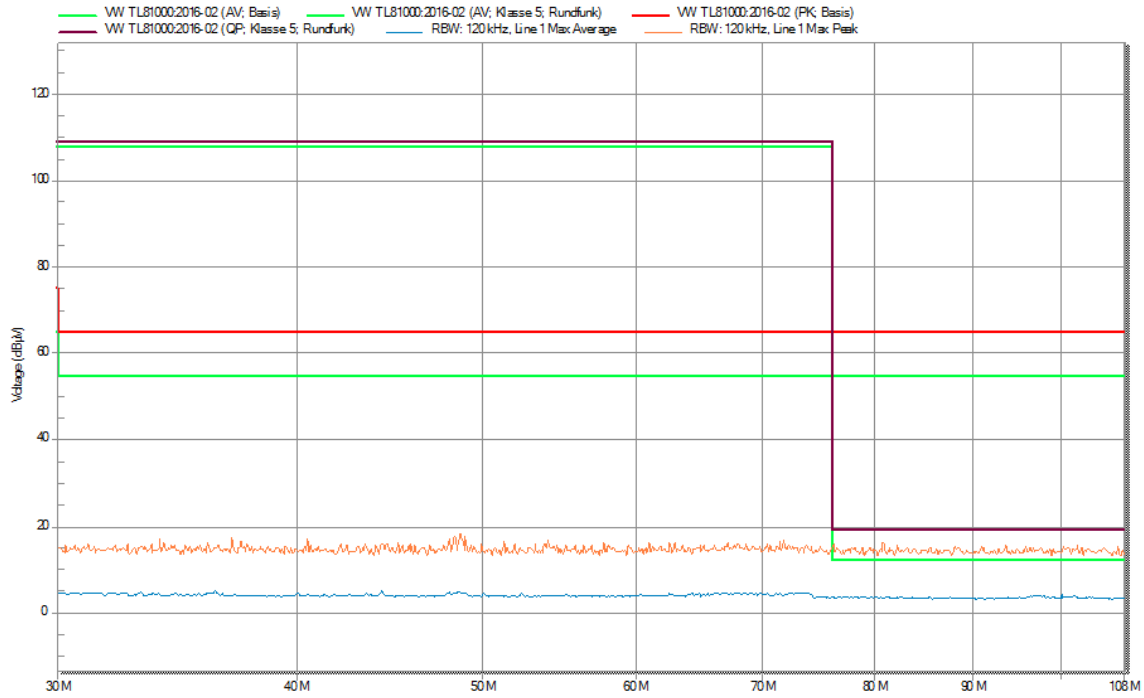

Figure 4: Results of conducted emission test between 30 and 108 MHz, with active PLC modem

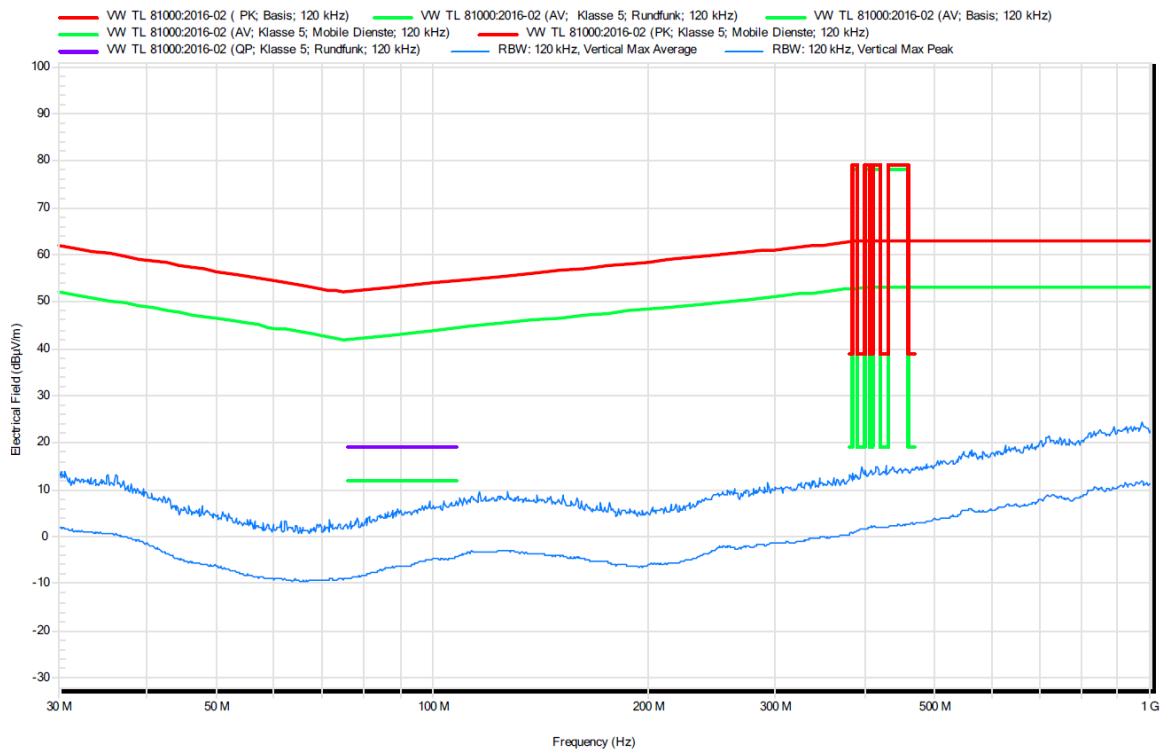

Figure 5: Results of radiated emission test between 30 MHz and 1 GHz, vertical polarization

## Interfaces

Figure 6 shows the schematic layout of the EMC optimized communication module and its interfaces:

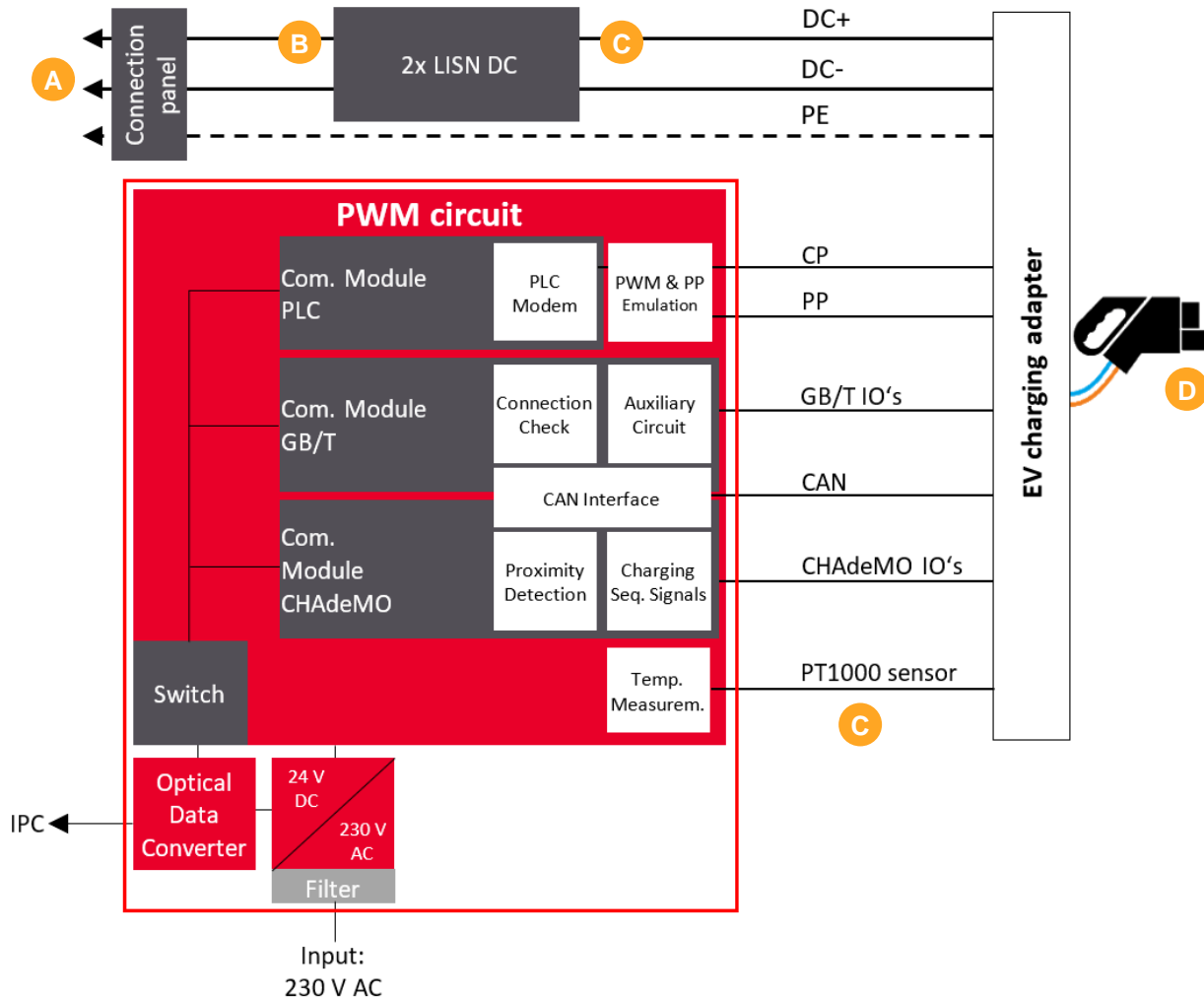
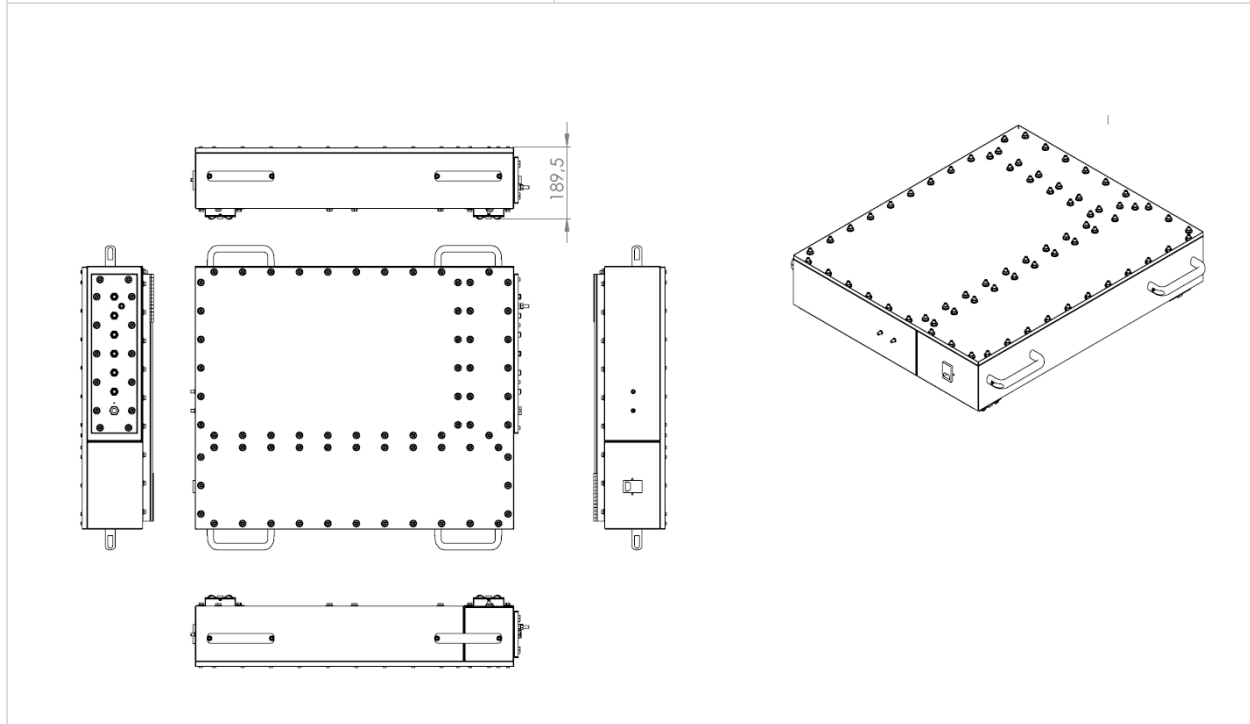

Figure 6: EMC optimized communication module (exemplary for DC charging)

- A. Connection from power source to Connection panel:
  - DC+ and DC- from “Dynamic DC Emulator” (located outside of the EMC chamber) through EMC. Often DC+ and DC- wires are installed underneath the EMC chamber. At Connection panel the cables are connected with LISN (Line Impedance Stabilization Networks) via HV plugs.
- B. Connection from Connection panel to LISN:
  - Unipolar DC+ and DC- connection between Lab specific connection panel and LISN (Line Impedance Stabilization Networks) terminals. Note: Cables and connectors are not included with this item.
- C. Connection from CDS/LISN to EV charging adapter:
  - DC+ and DC-: standard DC-cables from EV charging adapter
  - Communication (CP, PP, CAN): via shielded bus system cables by Phoenix Contact
- D. Connection to electric vehicle:
  - Via EV charging adapter

## Technical Data EMC Housing

Description	
Dimensions (H x W x D)	Approximately 800 x 880 x 190 mm
Weight	Approximately 45 kg
Power supply	24 V DC via 230 V AC C13 socket
Charging communication ports	<ol style="list-style-type: none"> <li>1. Communication Temperature</li> <li>2. Communication Control Pilot / Proximity Pilot</li> <li>3. Communication GB/T DC</li> <li>4. Communication CAN</li> <li>5. Communication CHAdeMO</li> <li>6. Communication CHAdeMO lock</li> <li>7. Auxiliary Power GB/T DC</li> </ol>
Interface to operator PC	2x ST-ST gigabit duplex optical fiber cable 50/125 $\mu$ m





## Measurements

Function / electric parameter		Range	Tolerance
PWM generator	Fundamental frequency	900 – 1100 Hz	± 0.1 Hz
	Open circuit voltage (adjustable, positive & negative)	± 0 – 15 V	± 0.02 V
	Pulse width	0 % – 100 %	± 0.05 %
	Maximum rise time	2 µs at Cc = 0 pF	
	Maximum fall time	2 µs at Cc = 0 pF	
	Minimum settling time to 95% of steady state	3 µs at Cc = 0 pF	
	Input resistance R1	1000 Ω ± 30 Ω	± 0.1 %
	Capacity Cs	300 pF	
	Capacitance Cc for emulating the maximum line capacitance	switchable: 0 / 1300 / 1500 / 2800 pF	± 5 %
Control pilot measurement	Voltage measurement	Measuring range: -15 V to +15 V 14-bit AD converter, 20 MS/s	± 10 mV
	Frequency measurement	900 to 1100 Hz	± 0.1 Hz
	Pulse width	0 to 100 %	± 0.5 %
	Rise/fall time	1 to 100 µs	± 1 µs
	Rise/fall time	1 MΩ + 100 pF	

## Real-time PC

The real-time PC is responsible for the test- and application execution and is normally placed in the control room near the EMC chamber. The technical specifications are shown in the table below:

Supermicro X10SBA	Value
Chassis	19-inch standard rack (½ U)
Processor	Intel J1900 / 4x 2,0 GHz
Memory	4 GB DDR3 RAM
Storage	128 GB SSD
Interface to operator PC	1,000 Mbit/s

## Optical Data Converter

The Optical Data Converter connects the EMC CDS with the real-time PC. It converts the light wave signals coming from the CDS into digital signals, which are then forwarded to the operator PC via an Ethernet interface.

Specifications	Value
Power input	5 V DC power supply (230 V AC input) is included
Standard protocol	IEEE802.3 10Base-T standard IEEE802.3u 100Base-TX/FX standard IEEE802.3z 1000Base-TX/FX standard
Connector	1x UTP RJ-45 connector 1x SC/ST/SFP connector
Operation mode	full duplex mode or half duplex mode
Transfer fiber	
Multi-mode	50/125, 62.5/125 or 100/140 µm
Single mode	8.3/125, 8.7/125, 9/125 or 10/125 µm

Note: Optical fiber cables are not in the scope of delivery. For connection of the Optical Data Converter with the CDS a separate feedthrough is necessary (through chamber wall). Feedthrough and work for installation are also not in the scope of delivery of this item.

## Documentation

- Operating manual
- CE conformity declaration

## SL1040A-301 Communication Module PLC

A PLC module supports the following additional functions:

- EVSE emulation according to the standards DIN SPEC 70121 (2014) and ISO 15118 (EIM only, Plug & Charge (PnC) will be available as software update in the future)
- Recording of all V2G messages and display of the information contained therein in plain text
- Manipulation of V2G messages and active delaying of timings (fault insertion)
- Testing of the PLC communication for adherence to the PLC level, the standardized frequency bands, the carrier frequencies, and the signal quality/strength
- Testing of the EV charging interface for compliance with the standard

Pin	Designation	Function	Charging interface
CP	Control Pilot	PWM control line plus digital communication via PLC	
PP	Proximity Pilot	EV testing of the charging cable connection	

**Note:** This option does not include electromechanical contacting (plug/inlet).

## SL1040A-302 Communication Module GB/T

A communication module supports the following additional functions:

- EVSE emulation according to GB/T 27930-2011 and -2015 (DC)
- Recording of all EV CAN messages and display of the information contained therein in plain text

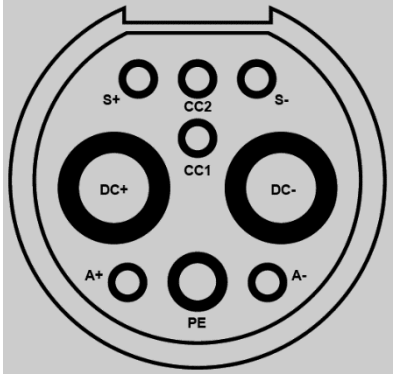
Pin	Designation	Function	Charging Interface
<b>S+</b>	CAN-High	CAN Bus: High level communication	
<b>S-</b>	CAN-Low		
<b>CC1</b>	Connection Check 1	EV testing of the charging cable connection	
<b>CC2</b>	Connection Check 2	EVSE testing of the charging cable connection	
<b>A+</b>	Auxiliary Circuit +	EVSE voltage supply* for EVCC	
<b>A-</b>	Auxiliary Circuit -	EVSE voltage supply* for EVCC	

**Note:** This option does not include electromechanical contacting (plug/inlet).

## SL1040A-303 Communication Module CHAdeMO

A communication module supports the following additional functions:

- EVSE emulation according to the CHAdeMO standard (protocol versions: 0.9; 0.9.1; 1.0.0; 1.0.1; 1.1; 1.2 and 2.0)
- Recording of all EV CAN messages and display of the information contained therein in plain text

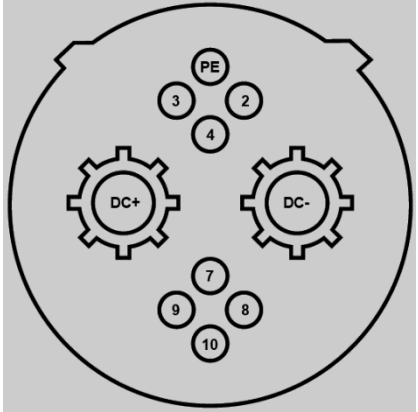
Pin	Designation	Function	Charging interface
<b>8</b>	CAN-High	CAN Bus: High level communication	
<b>9</b>	CAN-Low		
<b>7</b>	Connector proximity detection (CPD)	EV testing of the charging cable connection	
<b>4</b>	Vehicle charge permission (VCP)	EV opening for charging process	
<b>2</b>	Charging sequence signal 1 (CSS 1)	EVSE "start" charging	
<b>10</b>	Charging sequence signal 2 (CSS 2)	EVSE releasing the charging process	

**Note:** This option does not include electromechanical contacting (plug/inlet).

## EV charging adapters (EMC conform)

Charging Standard	Adapter	Rated Voltage	Rated Current	Cable Cross-Section	Weight	Standard
<b>Adapter for AC charging</b>						
SL1040A-601 EV charging adapter AC Type 1		250 V	32 A	3x 10 AWG (6 mm <sup>2</sup> ) L1, N; PE 2x 21 AWG (0,5 mm <sup>2</sup> ) CP, PP	pprox. 3 kg	IEC 62196-2 / SAE J1772
SL1040A-602 EV charging adapter AC Type 2		480 V	32 A	4x 6 mm <sup>2</sup> L1, L2, L3, N 1x 6 mm <sup>2</sup> PE 2x 0,5 mm <sup>2</sup> CP, PP	approx. 3 kg	IEC 62196-2
SL1040A-605 EV charging adapter GB/T AC		440 V	32 A	4x 6 mm <sup>2</sup> L1, L2, L3, N, PE 2x 0,5 mm <sup>2</sup> CP, CC	approx. 3 kg	GB/T 20234.2
<b>Adapter for DC charging</b>						
SL1040A-603 EV charging adapter CCS Type 1		600 V	125 A	2x AWG 1 (50 mm <sup>2</sup> ) DC+/- 1x AWG 3 (30 mm <sup>2</sup> ) PE 4x AWG 18 (1 mm <sup>2</sup> ) CP, PP, PTC	approx. 9 kg	IEC 62196-3 / SAE J1772
SL1040A-604 EV charging adapter CCS Type 2		1000 V	200 A	2x 70 mm <sup>2</sup> DC ± 1x 35 mm <sup>2</sup> PE 6x 0.75 mm <sup>2</sup> CP, PP, PTC	approx. 11 kg	IEC 62196-3
SL1040A-606 EV charging adapter GB/T DC		1000 V	250 A	2x 70 mm <sup>2</sup> DC ± 1x 25 mm <sup>2</sup> PE 6x 0,5 mm <sup>2</sup> S±, CC1/2, PTC 2x 2,5mm <sup>2</sup> A+/-	approx. 16 kg	GB/T 20234.3
SL1040A-607 EV charging adapter CHAdeMO		600 V	125 A	2x 35 mm <sup>2</sup> DC± 5x 0.75 mm <sup>2</sup> Signal + PE 2x 0.75 mm <sup>2</sup> communication lines	approx. 11 kg	CHAdeMO association

\* Limited by EV plug manufacturer's certification

\*\* All charging adapters have a standard length of 5 m. Other lengths available on request.

On the secondary side, all EV charging adapters are equipped with ring cable lugs on the unshielded power wires. The communication wires are equipped with shielded “bus system cables” by Phoenix Contact. The communication wires are equipped with compatible plugs for connection to the CDS separately, as shown in the following exemplary image:



Figure 7: Example of DC EV charging adapter

## Service Options

Service demand depends on the chosen hardware configuration, the installation location and its facilities, and especially the scope of testing. For that reason, it is difficult to estimate the exact amount of service required, prior to identifying all relevant requirements of the customer. The following times are estimates for a standard setup. Keysight offers a wide spectrum of services to guarantee a successful project and reduce the ramp-up time for our customers.

### Project Management and Technical Consulting Service

Project Management and Consulting Service is mandatory for every project including a construction, integration or customization part. However, Keysight recommends additional service in every Charging Discovery System project, in particular on the first order. By ordering the project management service, an experienced project manager or system specialist is dedicated to your project and acts as direct communication interface from Keysight to the customer's project team.

The project manager takes over the following responsibilities:

- Consult the customer with in-depth technical knowledge about the test solution, its application and relevant test standards.
- Learn about the customer's objectives and give guidance how to use the ordered solution best in order to gain maximum benefits.
- Evaluation of post-order requirements and change management.
- Coordinating and tracking project progress from day one until system handover.
- To provide complete and accurate project documentation to the customer.

### Installation Service

The scope of the installation service strongly depends on the customer facility. Keysight can provide full installation options for all products. To get a quote, provide all relevant information and requirements regarding test bench components that require media installation such as grid interface and cooling water supply with your local field engineer.

Note: Installation can also be executed by the customer.

## Commissioning Test

The Commissioning Test guides the customer during first usage of the test bench after installation. Commissioning Test Service is recommended for each test bench project. It includes:

- Support in commissioning the test system and instructions on how to use it.
- Local presence of experienced test bench engineer during first usage of the test bench.
- Consulting of customer personnel with regards to intended usage of the test bench (e.g. initial test with customer specimen, evaluation of test results)
- Inspection of hardware/laboratory installation
- Initial installation and configuration to the control software Charging Discover as well as hand-on instructions how to use it.
- Travel expenses

Note: Commissioning Test Service is offered on a daily basis. Keysight recommends at least two days of Commissioning Test Service for each test system.

## Productivity Assistance

The Productivity Assistance is offered to support, consult and train the customers operation personnel to reduce ramp-up time during the initial usage of a new test system and any unexpected system behavior during the test bench life cycle. Productivity Assistance is carried out remotely (phone or internet) or on site (on request). It includes:

- Direct access to an experienced system specialist via phone/internet.
- Trouble-shooting support
- Software and programming support & consulting (e.g. how to use, modify or create conformance/interoperability test cases)

Note: Keysight recommends at least three days of Productivity Assistance for each test bench project.

Learn more at: [www.keysight.com](http://www.keysight.com)

For more information on Keysight Technologies' products, applications or services, please contact your local Keysight office. The complete list is available at: [www.keysight.com/find/contactus](http://www.keysight.com/find/contactus)

